

***Whipple Superchargers
350 MAG/6.2MX MPI 350/377 Black Scorpion
Oil Cooler Installation Instructions***



WHIPPLE SUPERCHARGERS
3292 NORTH WEBER AVE
FRESNO, CA 93722
TEL 559.442.1261
FAX 559.442.4153

www.whipplesuperchargers.com

A color PDF of this manual is available, email
tech@whipplesuperchargers.com for a copy

***Version R1
Last Updated January 8th, 2013***

***WHIPPLE SUPERCHARGER INSTALLATION MANUAL
(MY2002-2008 350/377/383 Mercury engines)***

This product is intended for use on **STOCK, UNMODIFIED, WELL-MAINTAINED ENGINES**. Installation on a worn-out or modified engine is not recommended and could result in failure of the engine or the supercharger. It is recommended to perform a compression test of all cylinders, and perform a cylinder pressure leak down procedure. This will indicate the condition of the engine for reference. Whipple also highly recommends water block pressure and fuel pressure gauges for constant monitoring during operation.

*****NOTICE: Installation of Whipple Supercharger products signifies that you have read this document and have agreed to the terms stated within.***

It is the purchaser's responsibility to follow all installation instruction guidelines and safety procedures supplied with the product as it is received by the purchaser to determine the compatibility of the product with the vessel or the device the purchaser intends to install the product on.

Whipple Supercharger assumes no responsibility for damages occurring from accident, misuse, abuse, improper installation, improper operation, lack of reasonable care, or all previously stated reasons resulting from incompatibility with other manufacturers' products.

There are no warranties expressed, implied, for merchantability or fitness for engine failure, parts failure, any type of damage to vessel in any way, or reimbursement for labor or inconvenience.

STEP-BY-STEP INSTALLATION INSTRUCTIONS

1. Disconnect the battery power by selecting the disconnect mode on the battery switch or removing the ground cable from all batteries.
2. Drain the engine oil using the factory drain fitting.
3. Remove the return hose from the oil filter adapter and port side, bottom of block. This line will not be used.

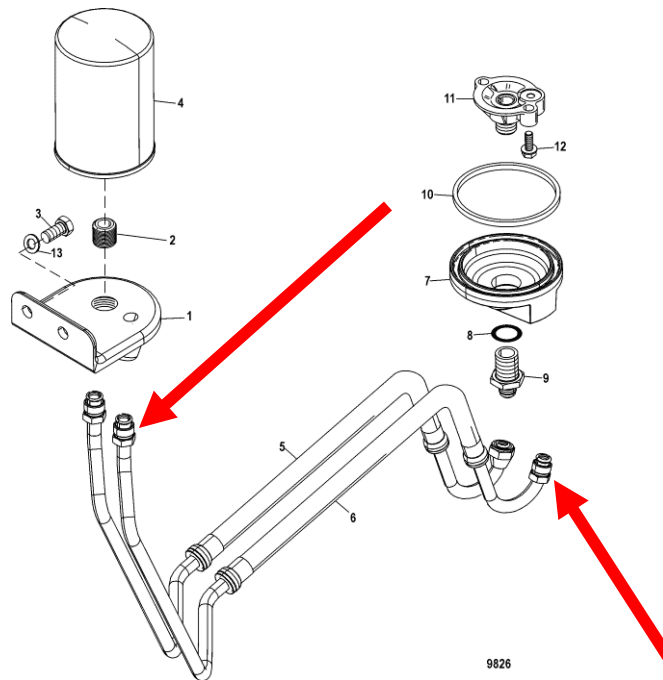

4. Install the supplied inverted flare to -8AN fitting into oil filter adapter.

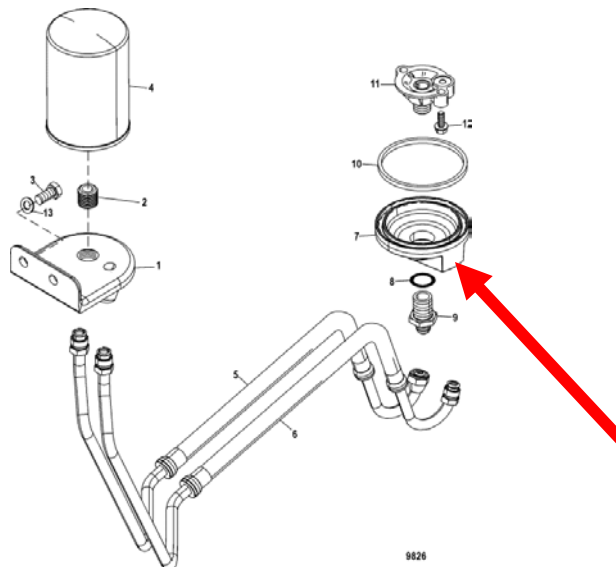

Oil Cooler Installation Instructions for Mercury 350/377/383 Mercury Engines

5. Mount the oil cooler in a secure location. Use the supplied billet brackets to secure.



6. Install the supplied $\frac{3}{4}$ " NPT to 8AN fittings into the oil cooler. Apply light amount of thread sealant to threads.
7. Install the $\frac{1}{2}$ " ID high psi hose to the supplied 8AN 90deg fitting. Install 90deg fitting to new fitting installed in the bottom of the oil filter adapter.

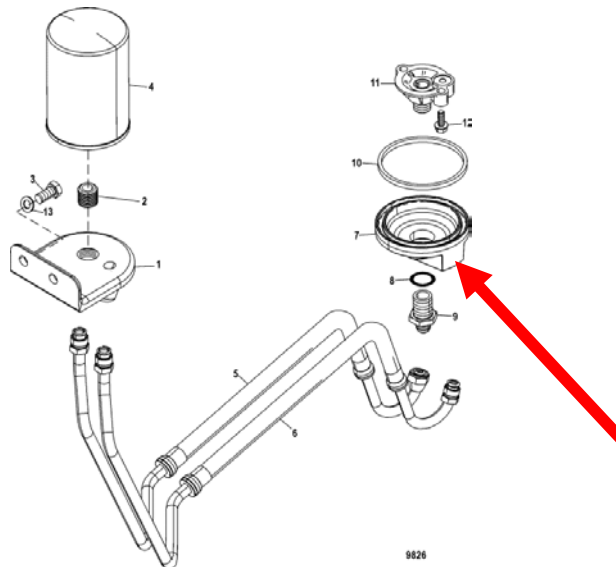

8. Route this line to one of the oil cooler 8AN fittings and install the supplied 98AN 90deg adapter to the hose end. Secure this fitting to the $\frac{3}{4}$ " NPT to 8AN fitting.

Oil Cooler Installation Instructions for Mercury 350/377/383 Mercury Engines

9. Install the brass inverted flare to $\frac{1}{2}$ " barb fitting into the oil filter adapter with the $\frac{1}{2}$ " hose pressed onto the barb. Route this line to the other $\frac{3}{4}$ " NPT to 8AN fitting in the oil cooler. Install the supplied 8AN to 90deg fitting to hose end. Secure both ends to fittings.

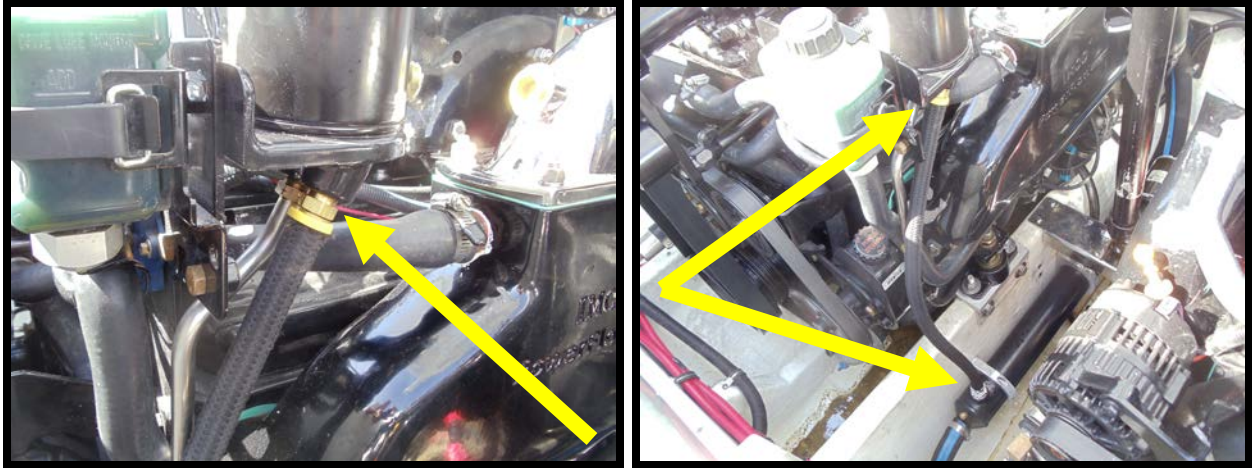

10. (When mounting on starboard side) Route $\frac{1}{4}$ " hose from the sea pump outlet, to the oil cooler $\frac{1}{4}$ " barb. Secure with dual #20 hose clamps. Route $\frac{1}{4}$ " hose from oil cooler outlet to factory power steering cooler located at the back of the engine. Secure with factory clamp.
11. (When mounting on port side) Route $\frac{1}{4}$ " hose from factory power steering cooler (located on back of engine) to the oil cooler $\frac{1}{4}$ " barbed fitting, secure end with dual #20 hose clamps. Route $\frac{1}{4}$ " end from oil cooler outlet back to factory fuel cooler or factory adapter depending on model year.