

*Whipple Superchargers
350 MAG/6.2MX MPI Installation Instructions*



WHIPPLE SUPERCHARGERS
3292 NORTH WEBER AVE
FRESNO, CA 93722
TEL 559.442.1261
FAX 559.442.4153

www.whipplesuperchargers.com

A color PDF of this manual is available, email
tech@whipplesuperchargers.com for a copy

PREMIUM FUEL ONLY (91 OCTANE OR BETTER ALWAYS) RON+MON/2

*Version B1R1
Last Updated October 2nd, 2012*

WHIPPLE SUPERCHARGER INSTALLATION MANUAL
(MY1999-2001 350/377 Mercury engines)

This product is intended for use on **STOCK, UNMODIFIED, WELL-MAINTAINED ENGINES**. Installation on a worn-out or modified engine is not recommended and could result in failure of the engine or the supercharger. It is recommended to perform a compression test of all cylinders, and perform a cylinder pressure leak down procedure. This will indicate the condition of the engine for reference. Whipple also highly recommends water block pressure and fuel pressure gauges for constant monitoring during operation.

YOU MUST SEND YOUR ECU IN FOR REPROGRAMMING TO WORK WITH THE WHIPPLE SUPERCHARGER SYSTEM. ACCOMPANY EACH COMPUTER WITH NAME, SHIPPING INFORMATION, CONTACT INFO, BOAT INFO AND IF ANY MODIFICATIONS HAVE BEEN MADE TO THE ENGINE. SEND FACTORY ECU TO:



Ship to:
WHIPPLE SUPERCHARGERS
ATTENTION: MARINE ECU RECAL DEPARTMENT
3292 N. WEBER
FRESNO, CA 93722
559.442.1261

****NOTICE:** *Installation of Whipple Supercharger products signifies that you have read this document and have agreed to the terms stated within.*

It is the purchaser's responsibility to follow all installation instruction guidelines and safety procedures supplied with the product as it is received by the purchaser to determine the compatibility of the product with the vessel or the device the purchaser intends to install the product on.

Whipple Supercharger assumes no responsibility for damages occurring from accident, misuse, abuse, improper installation, improper operation, lack of reasonable care, or all previously stated reasons resulting from incompatibility with other manufacturers' products.

There are no warranties expressed, implied, for merchantability or fitness for engine failure, parts failure, any type of damage to vessel in any way, or reimbursement for labor or inconvenience.

For best performance and continued reliability the following are **MANDATORY**.

1. USE ONLY PREMIUM GRADE FUEL (91 OCTANE OR BETTER).
2. ALWAYS LISTEN FOR ANY SIGN OF ENGINE KNOCKING, IF PRESENT DISCONTINUE USE IMMEDIATELY.
3. DO NOT OPERATE ENGINE IN BOOST IF THE FUEL PRESSURE IS BELOW THE PRESSURE SPECIFIED BY WHIPPLE INDUSTRIES.
4. NEVER CHANGE COMPUTER CALIBRATION (Engine fuel, ignition timing, or the RPM limiter, nothing)! THIS COMPLETE SUPERCHARGER SYSTEM IS DESIGNED AND ENGINEERED TO MAXIMUM PERFORMANCE FROM THE WHIPPLE CALIBRATION. MODIFICATIONS MAY CAUSE SERIOUS DAMAGE TO THE ENGINE.

WARNING! The most important precaution you must take with the WHIPPLE CHARGER is **cleanliness**. This supercharger is a high quality, close tolerance compressor that cannot be subjected to dirt or any type of foreign material. Foreign material entering the supercharger will automatically void all warranties. DO NOT remove the protective seal on the supercharger prior to installation.

***WARNING!! CONSTANT ABUSE OF THE REV LIMITER
WILL CAUSE SEVERE ENGINE FAILURE!!***

GENERAL INFORMATION

This system requires a major fuel system modification. Use extreme caution around the high flammable fuel and fuel vapors.

Always wear appropriate safety goggles and gloves when required.



Always use caution around flammable liquids.

Run the engine before beginning installation of the kit until the fuel level is as close as possible to empty. Make sure that fuel tank does not have old gasoline and contains only fuel that is 91 octane or better before installing supercharger kit. If the octane of the fuel in the tank is old or unknown, **drain the tank until empty and fill with 91-octane premium fuel or higher.**

You will be required to disconnect all of the wiring connectors. It is very helpful to tag all wires for future reference.

PROPPING RPM RANGE

The Whipple small block EFI SC system has a RPM limit of 5750rpm. The Smartcraft Overspeed warning comes on at 5650 to let you know you are near max RPM. Maximum engine life will be from 5200-5400 max propping rpm. Short burst above 5400rpm will not be a problem, but prolong abuse of this rpm will shorten engine life, most noticeably valve train life.

RECOMMENDED PREPERATION FOR INSTALL

It's mandatory that you replace the factory spark plugs with a minimum of **NGK BR7EFS**. Proper spark plug gap is .035". Failure to replace spark plugs to the colder NGK could result in engine failure.

TOOLS RECOMMENDED

The following tools are required to complete the installation of this supercharger kit. Metric socket set, standard socket set, screwdrivers, torx head sockets, standard and metric end wrenches, standard and metric Allen wrenches, blue and red Loctite™, Teflon tape or thread sealant, electric or battery operated drill motor, various hole saws, electrical tape, wire crimpers or solder iron, 0-60 lb. fuel PSI gauge with line kit and a torque wrench. You may also want to tag each wire connection for easy installation.

EXTRA PARTS REQUIRED

The factory engines from Mercury are not equipped with oil coolers and have a very limited oil supply. Under WOT running, oil temp can reach critical levels and cause damage. Therefore, a remote mounted oil cooler his **HIGHLY** recommended. A low to medium duty cooler will significantly increase the reliability of the engine. This will increase oil capacity as well as help maintain oil temps.

Extra gauges for increased awareness. We recommend running a electric fuel PSI gauge (0-60psi) for monitoring only (never tune from). We also recommend running a vacuum/boost gauge (0-15lbs) so you can monitor the boost level. When running in long periods, you will have more reliability and better fuel economy if you lessen the load on the engine by more trim and less boost.

SYSTEM PERFORMANCE INFORMATION

An electronic scanner is a tool used to display various engine parameters. This scanner can be installed and monitor all engine parameters while the boat is being operated. Some of these are items are: RPM, TPS volts, COOLANT temp, Oil PSI, Spark advance, IAC percentage and any TROUBLE CODES. You can purchase a hand held scanner from Rinda Technologies, for more information, go to www.rinda.com or (773) 736-6633. Rinda and Mercury Marine (for Mercury dealers) also offer laptop based programs that allows data logging and other features.

1. Idle speed system check - After the engine is at normal operating temperature (120deg. F), the engine will idle at 600 - 700 RPM, out of gear. To check the idle speed system, TPS voltage must be checked and set between .48-50v (using scan tool). You can use a MerCruiser scanner, Rinda scanner, Diacom Plus or a voltmeter. The light blue wire is your signal wire, the TPS is a 5v sensor. Without a scan tool, monitor the engine rpm. The motor should never die when shifting or decelerating, if it does, it will need more air through the throttle blades. Open the throttle stop to increase the air flow at idle. Make sure to test in the lake, in gear, rpm should only drop slightly while in gear. If it falls below 550, it needs more air to idle properly in gear. *Note: The engine must be turned off for 5 seconds and re-started to properly reset the learning of the IAC system.*

2. Engine Guardian. The Whipple SC system utilizes the factory sensors. The guardian system, when it detects a fault will limit the engine RPM until the code is removed or goes away. The factory horn will also beep to notify you of a potential problem. The most common is engine coolant temp, ideal temp operation is 120-140deg F and overtemp is set at 160deg F. Power may be reduced (reduced max engine rpm) if the temp exceeds 145deg F above 4000rpm) before setting a code.

3. Supercharger By-pass system. The supercharger is installed with a by-pass system. This allows the supercharger to operate at higher efficiency under vacuum operation. It is advised to verify the operation of the bypass valve. At idle and low engine loads, the bypass will be open. At higher loads (engine in boost) the bypass will be closed. As the throttle is opened quickly the bypass valve will close momentarily. This verifies the bypass will close and is functioning. If an actuator fails (from a misfire, back fire, etc), then it should be replaced immediately.

Actuator failure could lead to intercooler fires, poor performance and erratic idle. If the actuator fails, it could have an air leak which will result in poor idle qualities. A failed actuator will also allow the bypass to open it's internal butterfly during boost, which will circulate air and reduce airflow to the engine, consequently lowering the boost level and power.

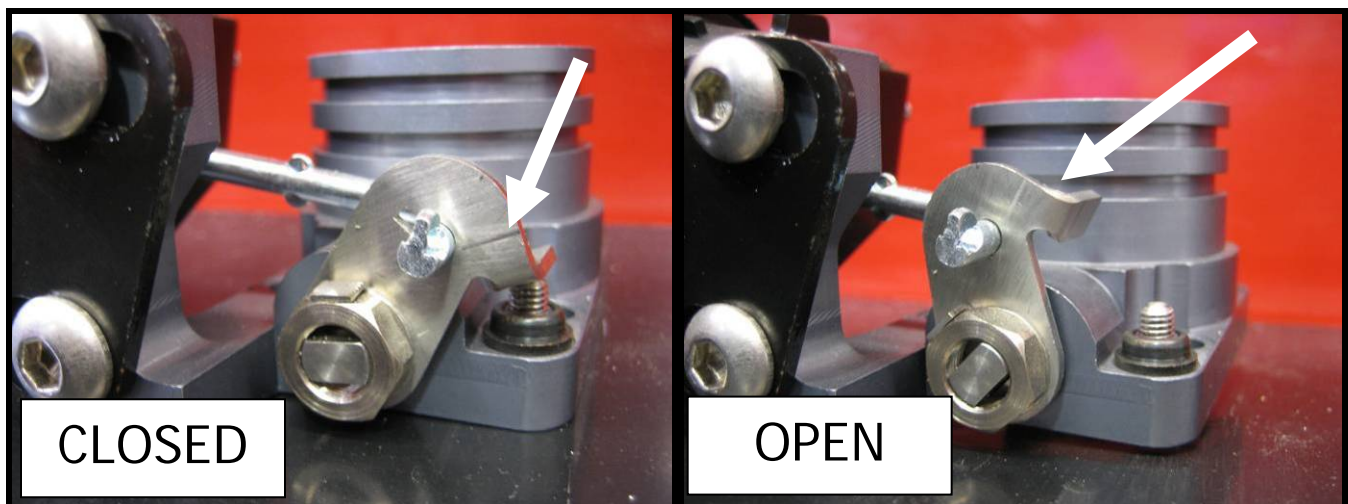

1. Move actuator arm into actuator.
 2. Plug top port with finger while actuator is pressed in.
 3. Let go of actuator arm while finger is still on top port.
 4. If actuator is good, actuator arm will stay in the same position until you remove your finger. If bad, it will come back to it's relaxed position.
- IF BAD, REPLACE IMMEDIATELY

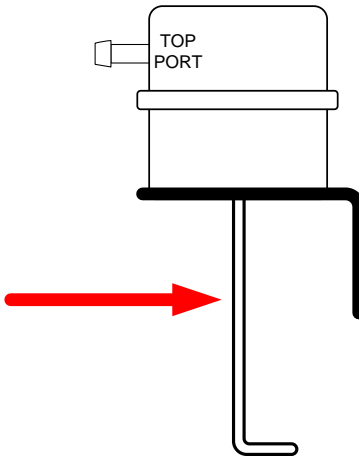

SYMBOL KEY

Throughout this installation guide you will see the following symbols used:

NOTE

Used to indicate tips and information to aid in installation, maintenance, or use of the supercharger.

!! CAUTION !!

Used to indicate precautions that must be taken to avoid damage to the supercharger and associated components.

⚠ WARNING!!



Used to indicate precautions that must be taken to avoid bodily injury as well as damage to the supercharger and associated components.

COMMON ABBREVIATIONS

SC	Supercharger
IC	Intercooler
ECT	Engine Coolant Temperature
IAT	Inlet Air Temperature
IAC	Idle Air Control
TPS	Throttle Position Sensor
MAP	Manifold Absolute Pressure
PCV	Positive Crankcase Ventilation
DEG	Degrees
KPA	Kilopascal
WOT	Wide Open Throttle
V	Volts
GND	Ground
ECM	Engine Control Module

GENERAL INFORMATION

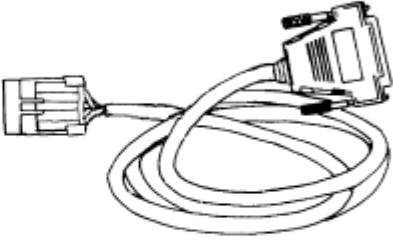
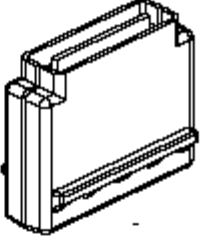
Run the engine before beginning installation of the kit until it is as close as possible to empty. Make sure that fuel tank does not have old gasoline, and contains only fuel that is 91 octane or better, before installing supercharger kit. If the octane of the fuel in the tank is old or unknown, **drain the tank until empty and fill with 91-octane premium fuel.**

<p>Harness Assembly / Diagnostic Tester</p>	<p>91-822560A13</p>
<p>Description: 25-pin to 4-pin Adaptor harness. For PCM 555 and ECM 555 models (4-pin connectors, no additional harness required).</p>	 <p>74214</p>
<p>Mercury MerCruiser DDT Cartridge Version 1.2</p>	<p>91-880118A2</p>
<p>Description: Use on PCM 555 and ECM 555 models.</p>	 <p>78036</p>
<p>Scan Tool Kit / Version 4.0</p>	<p>Note in Description</p>
<p>Description: Hand-held Scan Tool updated for 2001. (refer to Service Bulletin 2001-1). Use with models: MCM/MIE EFI (TBI) and MPI Gasoline MCM/MIE 496/8.1S MPI PCM 555 1997 and Newer MCM/MIE Carbureted Models with Thunderbolt Ignition System MCM/MIE D-Tronic Diesel NOTE: Tool must be ordered from Rinda Technologies, Inc.</p>	 <p>72428</p>

STEP-BY-STEP INSTALLATION INSTRUCTIONS

1. Disconnect the battery power by selecting the disconnect mode on the battery switch or removing the ground cable from all batteries.
2. Remove the factory PCM for recalibration, ship to Whipple Superchargers for recalibration.
3. Remove stock spark plugs, (Whipple Superchargers recommends a NGK BR7EFS). Always check gap and only run plug gaps of .032" - .035". Torque to 11 ft/lbs.
4. Removal of stock parts:
 - Remove the plastic engine cover.
 - Remove the factory shift bracket assembly and set to the side of the engine for later relocation.

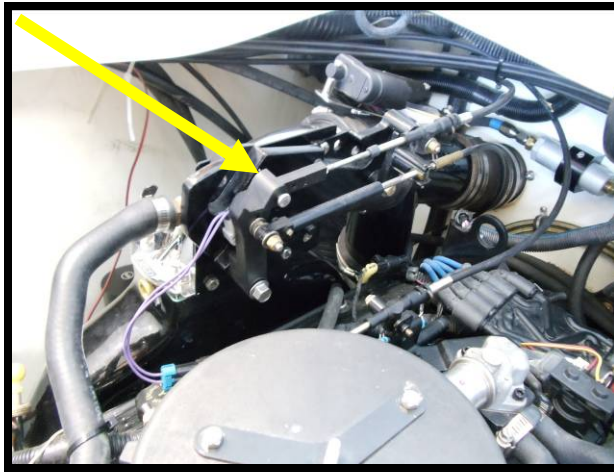

- Unplug factory MAP (manifold pressure) sensor connector.
- Unplug coolant electrical connector from coolant temp sensor.

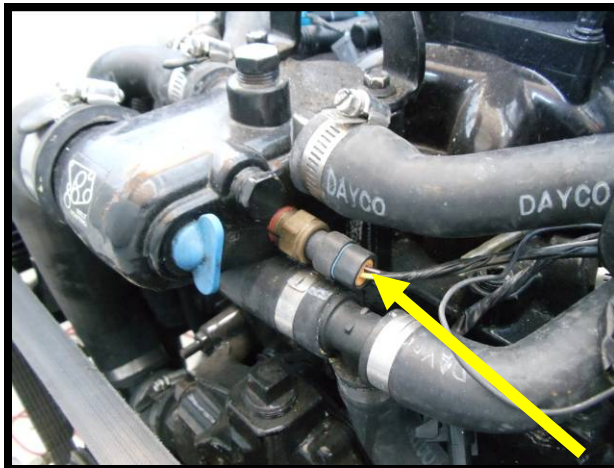

Whipple Charger Installations Instructions for Mercury 350/377 Mercury Engines

- Unplug coolant temp sender connector from sender.

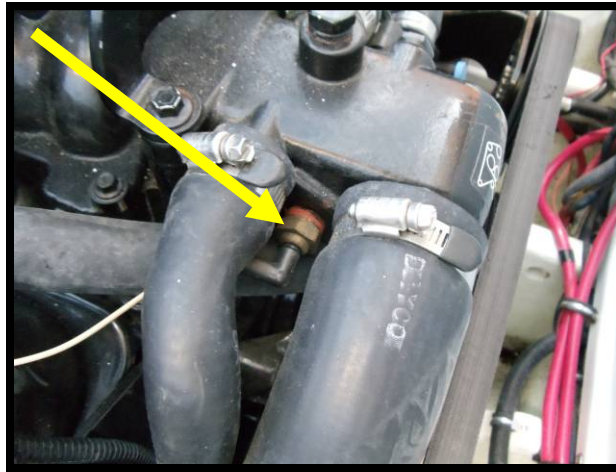

- Remove the coolant temp sensor with a 3/4" deep well socket.
- Remove the coolant temp sender with a 18mm deep well socket.
- Remove the thermostat housing and all of its hoses from the housing.
- Find the TPS sensor and remove the connector by unlocking the locking tab and pulling away.

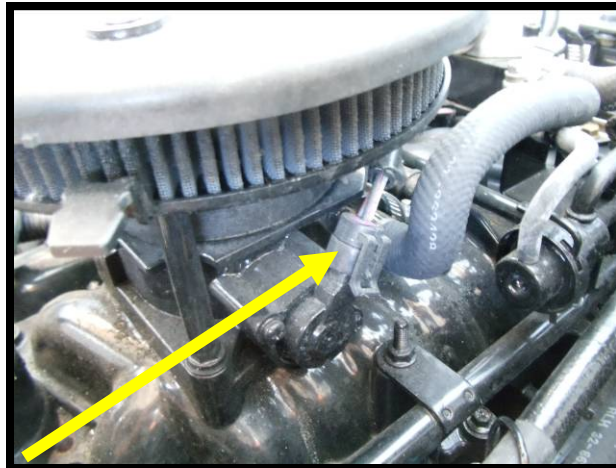

- Disconnect gear lube bullet connectors.

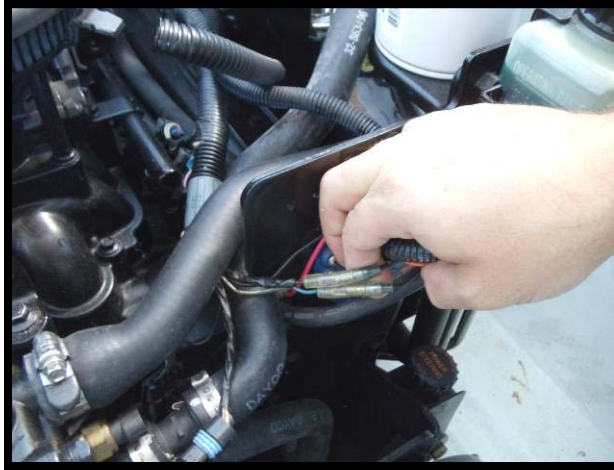

5. Remove IAC motor from engine by removing the (2) SHCS with a 3/16" allen wrench.
6. Remove distributor cap.
7. Crank engine over by hand so that it's at #1 cylinder TDC. Verify that the rotor tang is in the proper location.
 - Mark distributor, front and center for later installation.
 - Remove distributor from engine.
8. Set 50-amp, starter solenoid and Merthacode to the back of the engine for later installation.
9. Remove the 1/8" rubber fuel psi reference line from the plastic tee (hose will be used later, disregard the tee).
10. Remove factory hoses from thermostat housing by loosening hose clamps with 5/16" socket or nut driver and a hose removal tool to loosen hose from thermostat housing.
11. Loosen the belt tensioner holding nut with a 5/8" socket. Release the tension on the idler pulley with a 3/8" wrench, walk the idler down the bracket and remove belt.



Whipple Charger Installations Instructions for Mercury 350/377 Mercury Engines

12. Remove the 4 hex bolts from the crankshaft accessory drive pulley.
13. Remove the self-locking nut and washer holding throttle cable to the throttle shaft and washer with a 7/16" socket.
14. Remove the throttle cable and temporarily install the washer and nut to the throttle shaft. Save the 2 steel sleeves for later use.
15. Remove throttle bracket from engine by removing the (2) nyloc nuts using a 10mm socket.
16. Remove the flame arrestor by removing the (3) nyloc nuts with a 10mm socket.
17. Remove the PCV line from the factory intake manifold.
18. Unplug all 8 injector connectors from injectors.
19. Remove the factory fuel line from the port side fuel rail.
20. Remove intake manifold (8 bolts), using a 13mm socket. In some cases, it may be easier to loosen one valve cover to allow the manifold to come up.
21. Remove Whipple intake manifold from intercooler/SC assembly. The unit is partially assembled for freight, but is not sealed or torqued.
22. Clean factory intake manifold surface using a gasket scraper or razor blade.
23. **➤ NOTE.** Apply a thick bead in the valley of the block, both front and rear. This should be a minimum of 3/8" tall. Make sure to circle all 4 water passages, this will ensure no water leaks later.



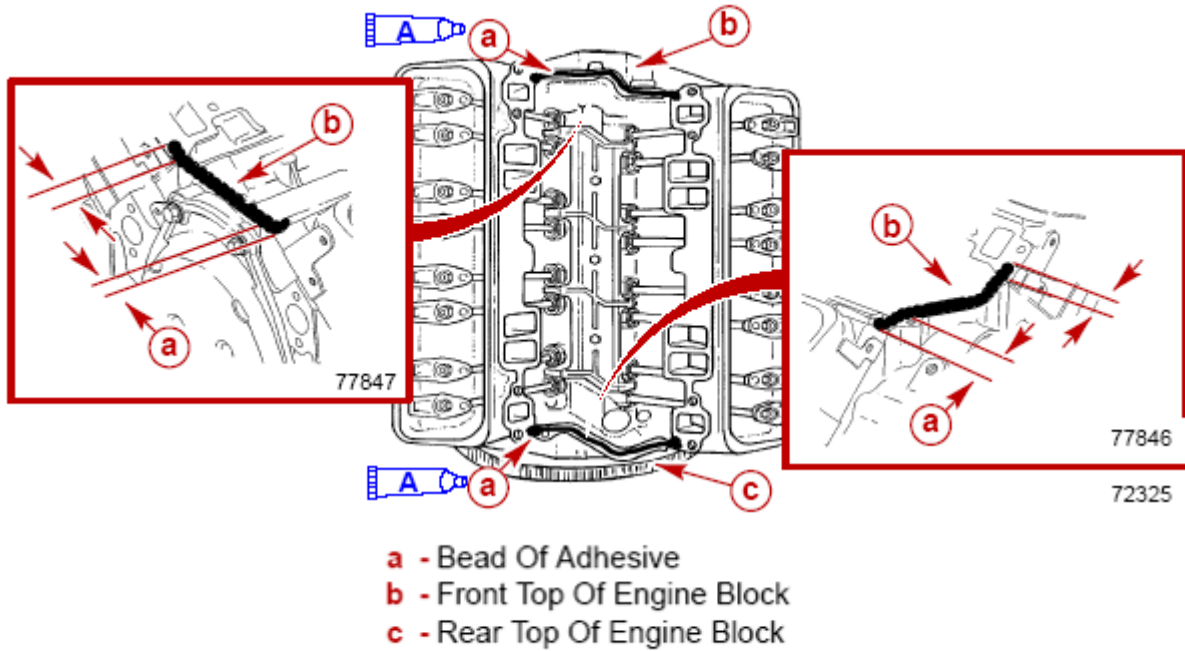

24. Install the supplied intake gasket set. Apply black RTV silicone around all 4 water passages.

25. Install intake manifold using the factory 8 hex head bolts. Starting from the center out, make 3 passes:

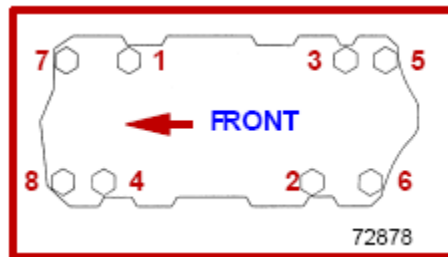

- Torque to 27 in/lbs.
- Torque to 106 in/lbs.
- Torque to 132 in/lbs.

➤ **NOTE:** Install all bolts hand tight and slide intake forward as much as possible, and then stab the distributor to make sure everything lines up. If it does, proceed, if it does not, you may have to file one of the openings.

26. Secure the factory distributor with the factory clamp and the supplied 3/8" x 3/4" hex head steel bolt and 3/8" flat steel washer. Torque to 18 ft/lbs.

27. Re-install distributor cap and factory spark plug wires.

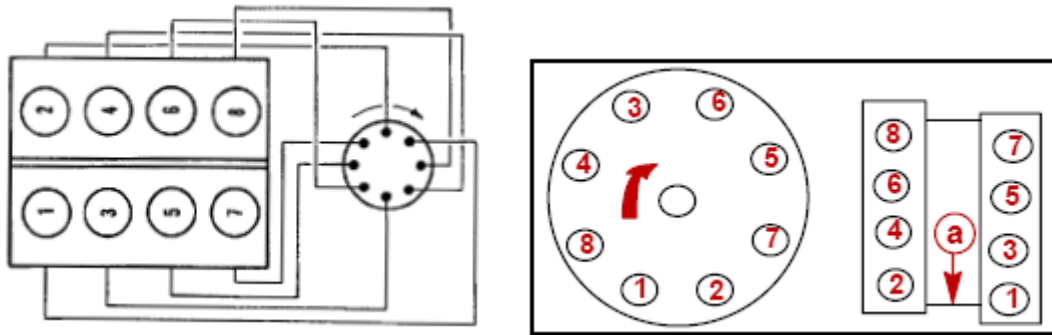

28. Install factory IAC motor to new billet throttle body using the supplied (2) torx bolts.

29. Wiring modifications:

Locate the factory 8 injector connectors. Pull these wires out of the split loom by using a sharp razor to split the electric tape (be careful not to slice wires). You will find a solder joint where these wires end up going to only 3 wires (2 turn on grounds, 1 constant 12v). Cut the factory injector connectors off when you get to the 3 wires.

Locate the 6 injector pigtail preinstalled on the new injectors. Disconnect the 3-way pigtail with the bare wire ends. Using the salmon colored butt connectors, connect these to the 3 factory injector wires. Once these wires are butt connected, use a heat gun to shrink the connectors for proper sealing from water.

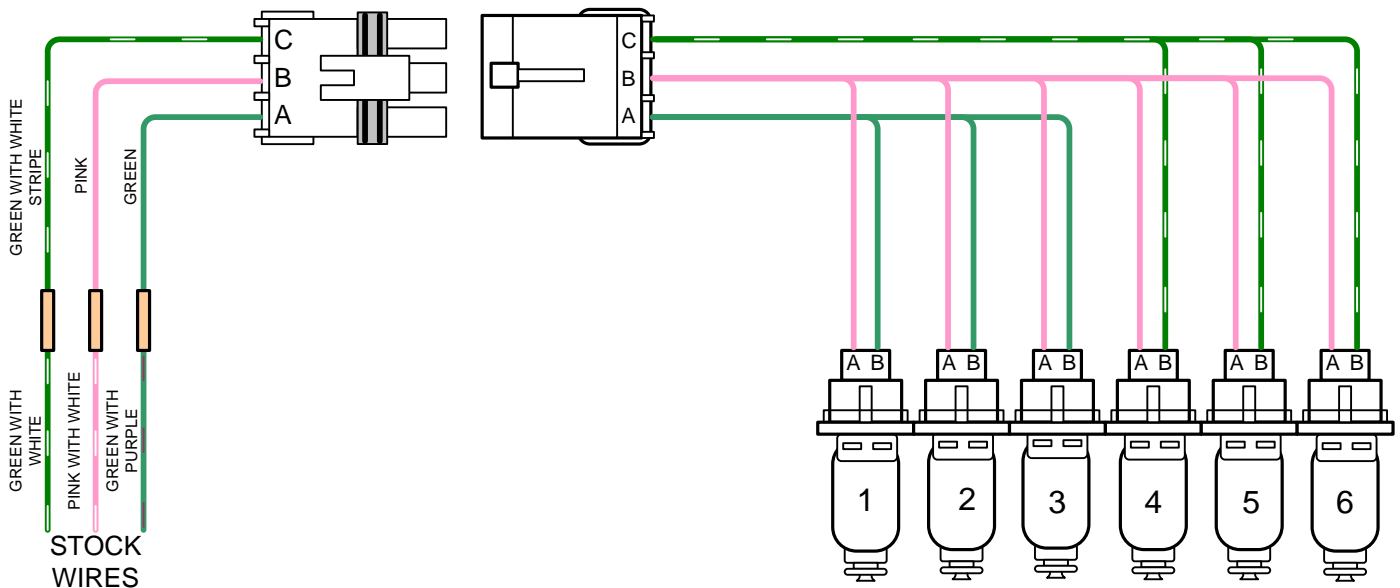

Install the supplied female to male 3-pin adapter for the MAP sensor wire. Route to new MAP sensor located on the back of the front tensioner plate, connect to sensor.

Install the MSD 6M-2 box as shown in the diagram.

Whipple Charger Installations Instructions for Mercury 350/377 Mercury Engines

30. Remote mount the MSD 6M-2 box on the transom.

31. Connect the factory IAT sensor to sensor in manifold.

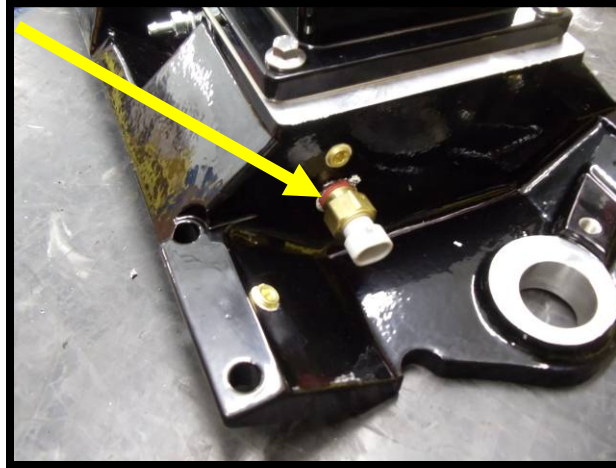

32. Remove factory fuel PSI regulator.

Cool Fuel System

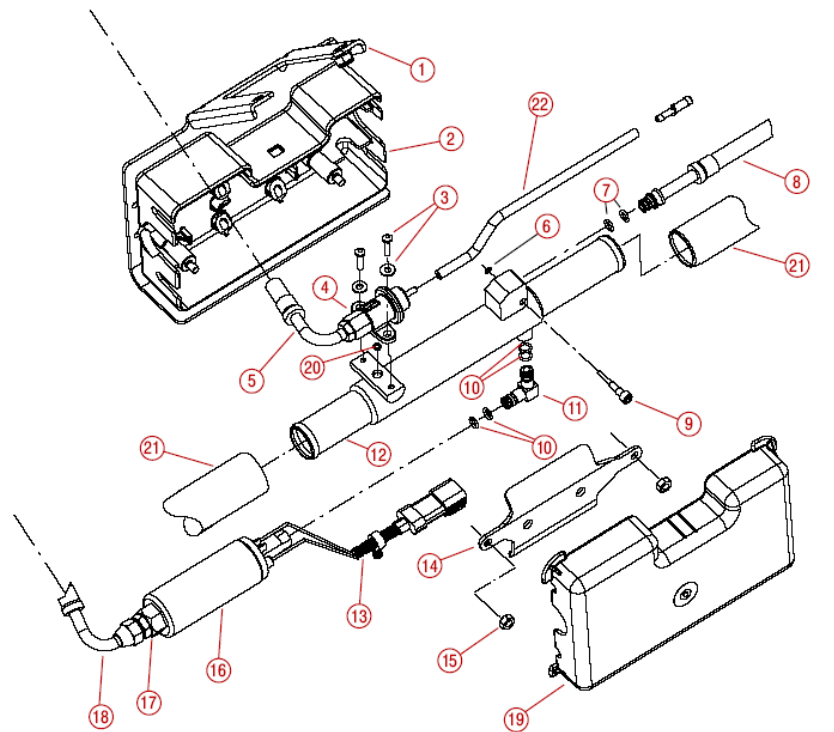

77941

- | | |
|---------------------------------------|---------------------------------------------|
| 1 - Bracket | 12 - Fuel Cooler |
| 2 - Cover Base | 13 - Fuel Pump Wiring Harness |
| 3 - Screw And Washer (2) | 14 - Retainer Bracket |
| 4 - Fuel Pressure Regulator | 15 - Nut (2) |
| 5 - Return Fuel Line | 16 - Electric Fuel Pump |
| 6 - Retaining Ring | 17 - Inlet Fitting |
| 7 - O-rings (2) | 18 - Fuel Line Inlet |
| 8 - Fuel Line, Fuel Pump-To-Fuel Rail | 19 - Cover |
| 9 - Stepped Screw | 20 - Filter |
| 10 - O-rings (4) | 21 - Seawater Hoses (Hose Clamps Not Shown) |
| 11 - Elbow Fitting | 22 - Vacuum Hose |

Whipple Charger Installations Instructions for Mercury 350/377 Mercury Engines

33. Cut the top of the regulator off as shown. ➡ **NOTE:** Clean debris after cutting.



34. Install spring in regulator and assemble regulator as shown by clamping around cut regulator using supplied oring to seal.



35. Reinstall fuel pressure regulator, this will require you to cut some of the plastic housing for it to fit correctly.

Whipple Charger Installations Instructions for Mercury 350/377 Mercury Engines

36. Install vacuum line on new regulator barbed fitting that was routed from factory. Install the supplied 5/32" plastic barb and 90deg rubber fitting. Connect this end to 5/32" barb fitting located in Whipple intake manifold. Secure with zip-tie. Note: Will have to remove to set fuel pressure later.



37. Re-connect factory fuel pump electrical connection.

38. Remove pipe plug from circulating pump, replace with the supplied 3/4" brass allen style pipe plug. Apply thread sealant to threads.

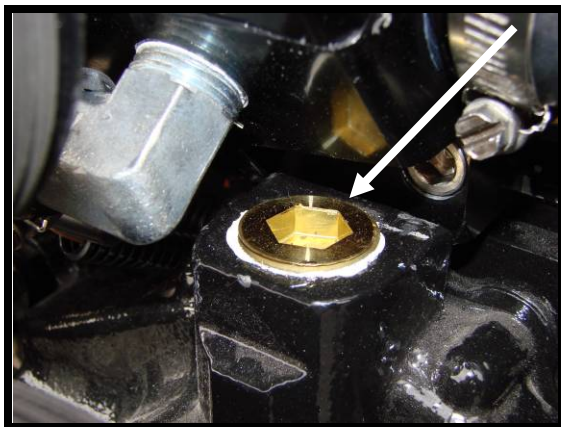
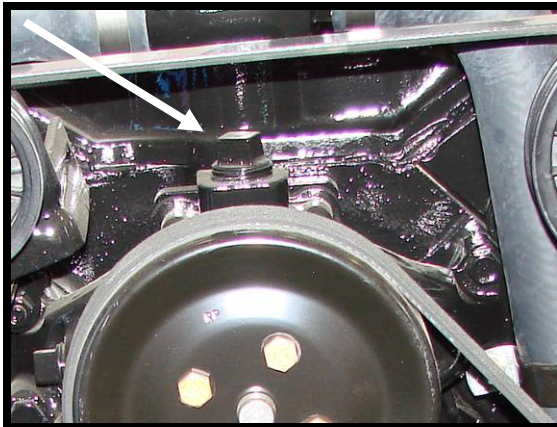

Whipple Charger Installations Instructions for Mercury 350/377 Mercury Engines

39. Install supplied low temp thermostat (120deg F) into manifold recessed area, pointed end facing out.

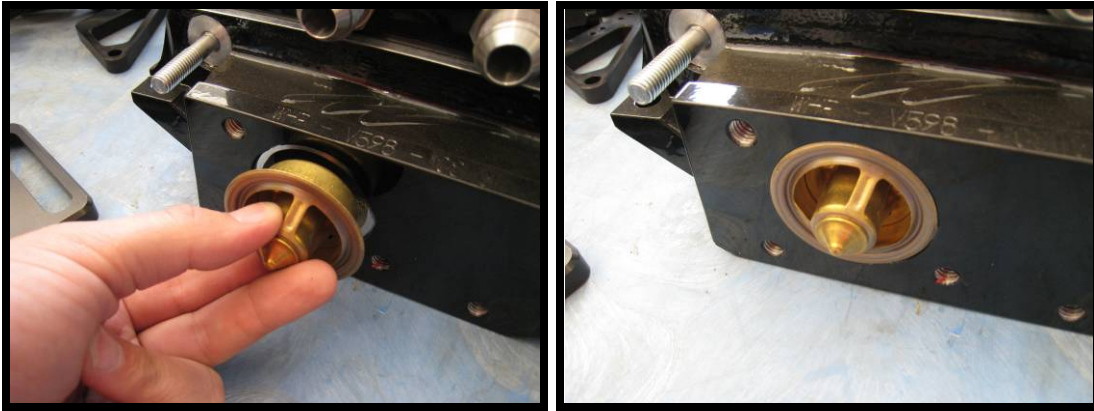

40. Install the base of thermostat housing using the supplied black RTV silicone (circle around each bolt passage) and 3/8" x 2" and 3/8" x 1 1/4" socket head allen bolts. Apply thread sealant to bolts, they go through the water passage. Torque to 20 ft/lbs.

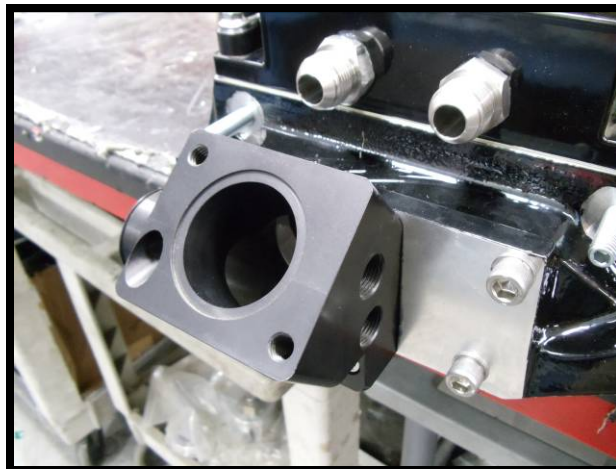

Whipple Charger Installations Instructions for Mercury 350/377 Mercury Engines

41. Install the 3/8" x 1/2" socket head allen bolts into the two empty bolt holes if not already previously done. Apply thread sealant to threads.

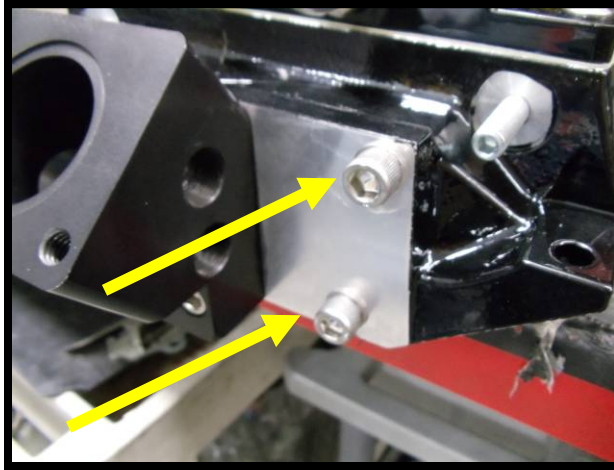

42. Install factory temperature sensor and gauge sender into thermostat housing. Apply thread sealant to threads.

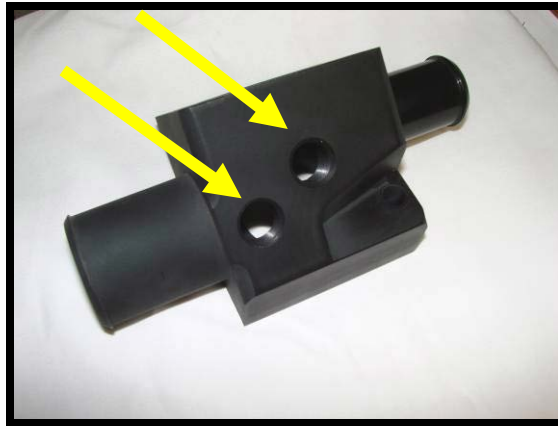

43. Extend the factory sender tan wire with the supplied tan wire and salmon butt connectors. Use heat gun to shrink butt connectors. Install the supplied plastic loom over the wire for protection. Route the wire below the thermostat housing and behind the water pump.

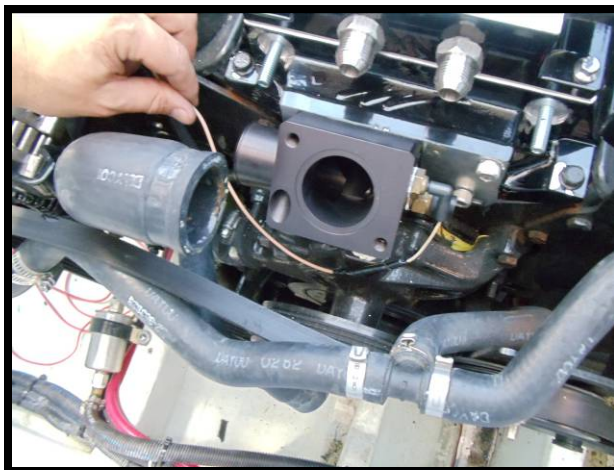

Whipple Charger Installations Instructions for Mercury 350/377 Mercury Engines

44. Route the stock 1 ¼" inlet hose coming from the port side of the engine and route to the 1 ¼" inlet barb on the new thermostat housing. Secure with hose clamp.

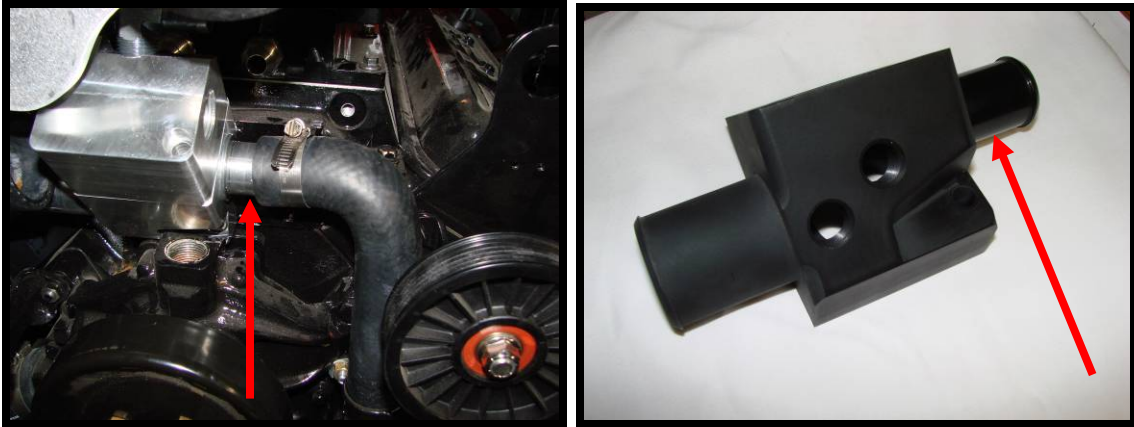

45. Install the thermostat housing top piece using the supplied black RTV silicone and the supplied (2) 3/8" x 2 ½" socket head bolts. Torque to 20 ft/lbs.



46. Remove the factory 1 ¾" circulating sea pump hose, cut approximately 2" - 3" of length from this hose, couple with the supplied stainless steel 1 ¾" hose coupler.

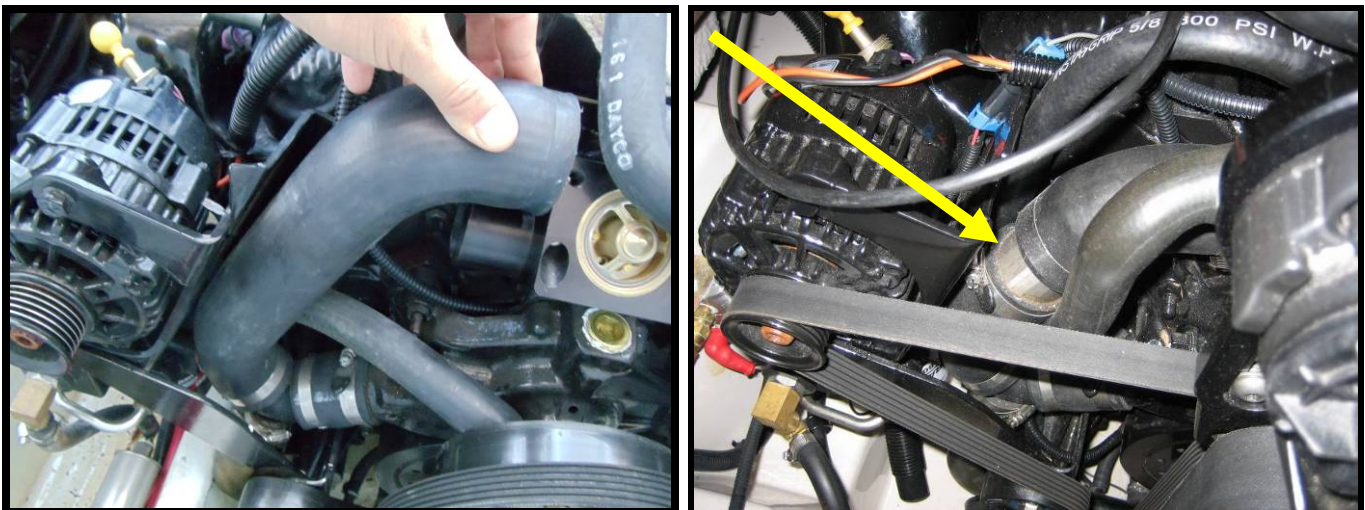

47. Install the 3/4" NPT to 1" barb fittings with pipe sealant into thermostat housing.

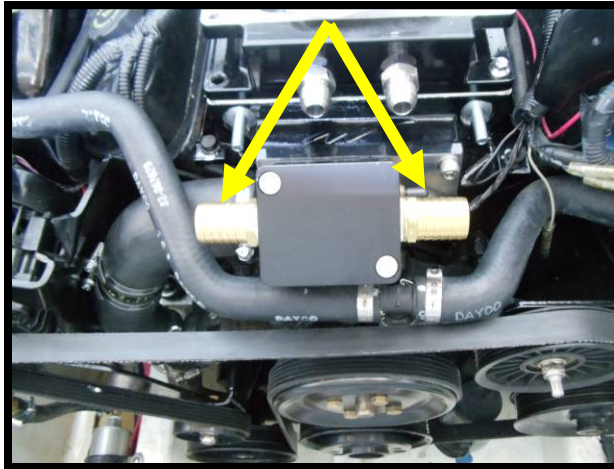

48. Reinstall the factory 1" rubber exhaust hose (bottom exhaust feed) to the 1" barb fittings in the thermostat housing top.

49. Install new crank pulley:

- Make sure the mounting surface of the new pulley on the front of the harmonic balancer is perfectly flat. If necessary, remove the imperfections or paint with a good flat file.
- Install the new Whipple crank pulley billet base to the harmonic balancer. Utilize the (3) 3/8" x 2" fine thread socket head allen bolts. Apply a light amount of blue Loctite on threads. Torque to 35 ft/lbs.
- Install the (1) 7/16" x 3" steel socket head allen bolt to the center of the crank pulley utilizing the factory flat washer, apply light amount of blue Loctite to threads. Torque to 60 foot-pounds.
- Install the Whipple crank 12-rib crank pulley to the billet base using the supplied (6) 3/8" x 1 1/4" steel socket head allen bolts with (6) 3/8" flat steel washers, apply light amount of blue Loctite on threads. Torque to 35 ft/lbs.
- Install factory 6-rib belt as it was stock. Tighten with the factory adjusting idler until belt is tight.

Sterndrive Models

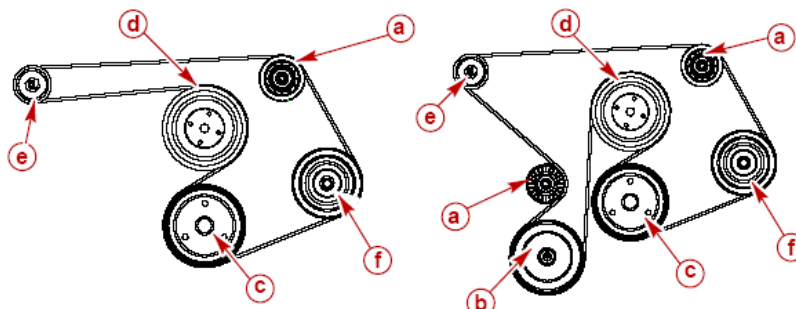

Without A Seawater Pump

With A Seawater Pump

- a** - Idler Pulley
- b** - Seawater Pump Pulley
- c** - Crankshaft Pulley
- d** - Circulating Pump Pulley
- e** - Alternator Pulley
- f** - Power Steering Pulley

50. Intercooler water routing:

- Install the supplied stainless intercooler tee fitting into the factory water system. The best possible location is just after the outlet of the sea pump before the power steering cooler. Cut the factory hose, insert tee and secure tee with the supplied #20 hose clamps. (**DO NOT INSTALL TEE BEFORE SEA PUMP INLET**)
- Install supplied 5/8" ID hose from the intercooler tee to the 90deg intercooler fitting. Secure both ends with the supplied #10 hose clamps.
- Install 5/8" ID hose from fitting and route to thru-hull fitting you installed earlier.

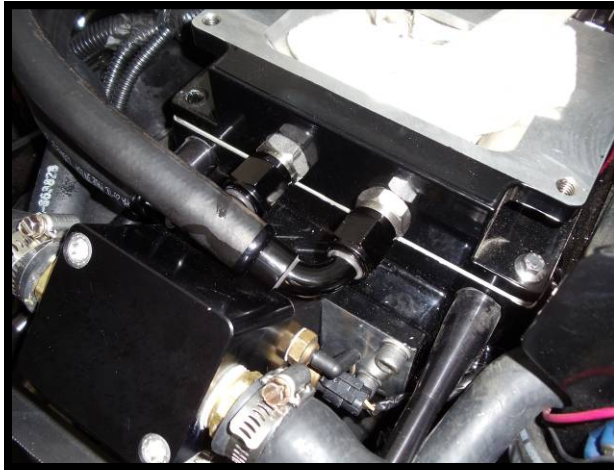

51. Water dump fitting: **DO NOT RESTRICT OUTLET.**

- Find visible location for thru-hull fitting above the water line.
- Mark your spot on the boat and drill a hole using a 7/8" hole saw.
- Apply marine type silicone to exposed wood and fiberglass as well as the back of thru-hull fitting.
- Insert fitting in boat and from the backside, install the aluminum nut. You will have to hold the dump fittings from twisting when installing. Smooth grip pliers work the best.
- Once tightened, wipe the excess silicone off and let the silicone dry.
- Install brass – 10 push lock fitting to intercooler dump fitting and follow by pushing the 5/8" ID hose on push lock fitting.



Whipple Charger Installations Instructions for Mercury 350/377 Mercury Engines

52. Apply light amount of gasket cinch to manifold top surface surface. Install supplied gasket to manifold top surface. If there is a problem with the gasket, you can use black RTV silicone (The Right Stuff/Permatex), approximately a 1mm bead to seal.
53. Install supercharger/intercooler assembly by lying on intake manifold with throttle cable assembly as well. ➡
NOTE: While installing SC/intercooler assembly, you must install the 3/8" x 1.5" socket head allen in the first throttle cable bracket/intercooler mounting area. It's too long to install afterwards.
- Install all other intercooler mounting bolts hand tight and then slide the compressor assembly forward. Now torque intercooler mounting bolts to 25 ft/lbs.
54. Front plate/support installation:
- Take the 7.16" round support stands and tighten on setscrews. The hex end will go against the SC/intercooler adapter plate, round end goes against manifold. Tighten using the hex area on stand.
- Take the front plate assembly and install the drive collar leaving all socket head allen bolts loose. Slide collar and plate over the drive leaving it all loose.
- Install the supplied 3/8" x 1.5" button head allen bolt and supplied .870" stainless washer into recessed and slotted area of front plate. This will secure the plate to the support stands. **Do not tighten, just install hand tight.**
- !! CAUTION !!** With the front plate pushed against the support stands, tighten the collar around the drive (one 1/4" allen bolt). Follow by tightening the (4) front 1/4" socket head allen bolts. **Apply a light amount of blue Loctite #242 to threads.**
- Torque the 3/8" X 1.5" button head allen bolts to 25 ft. lbs.
- !! CAUTION !!** Install the .50" (1/2") blower pulley spacer; follow by installing the blower pulley. Secure with the supplied 6mm x 22mm socket head allen bolts. Hold pulley from spinning by wrapping the supplied SC belt around pulley and pinch it together. Tighten blower pulley bolts to 110 inch pounds.

55. SC belt installation:

- Loosen the sliding idlers (grooved and smooth) with allen wrench or socket.
- Release the tension from the spring-loaded tensioner using a ½" breaker bar.
- Install the supplied 10 rib SC belt. Adjust the sliding idlers so the spring loaded tensioner is located in the middle of it's range.



56. Fuel system installation:

NOTE: The Whipple fuel system will only function properly when the fuel line inlet to the fuel filter does not have any large restriction.

- Remove the fuel psi sensor from fuel rail and install into Whipple fuel rail (not required).
- Remove the fittings from the fuel rail and separate the fuel fittings.
- Install the factory inverted flare to 1/4" NPT fitting into the supplied ¼" adapter fitting.
- Use the supplied fuel hose, 3/8" ID hose (high psi only) and barbed fittings to make your own fuel rail. Install double clamps on both fittings.
- On the new end, route line to port side of Whipple fuel rail. Install fitting onto -6AN fitting on fuel rail.



Whipple Charger Installations Instructions for Mercury 350/377 Mercury Engines

57. Install the 3/8" rubber 90 deg fitting on factory PCV valve (port side valve cover). Install the 3/8" plastic hose coupler into rubber 90 deg fitting. Route the new supplied 3/8" ID rubber hose from the factory PCV valve to the 3/8" barbed fitting located in the throttle body.



58. Install the supplied breather/filter (#1519) to the factory breather hose (starboard side valve cover) in the valve cover. Route to back of motor for clean installation.
59. Install supplied Merthacode bracket to the computer bracket to factory location using supplied 1/4" x 3/4" socket head allen bolts and nuts.

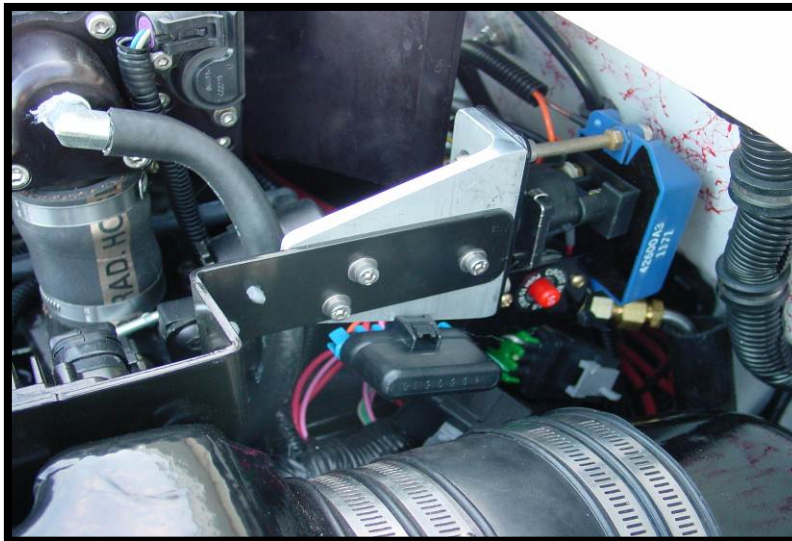

60. Wiring Instructions:

- Plug in factory ECT gauge sender connector (single wire) to sender you relocated to the new thermostat housing.
- Plug in factory ECT connector to ECT sensor you relocated to the new thermostat housing.
- Plug in factory TPS connector to TPS sensor mounted on throttle body.
- Plug in factory IAC connector to IAC motor mounted on throttle body.
- Plug in the new MAP sensor connector to MAP sensor (located in manifold).
- Plug in the air temp sensor connector located in the back of the manifold.

61. Fill the new s/c compressor with oil.

- Make sure the SC is sitting square/flat.
- Remove -4AN allen plug and fill SC with **WHIPPLE SC OIL ONLY!!**
- Fill to the middle of the sight glass. NOTE: The W140AX compressor takes a maximum of 5.8 fl/oz.
- Reinstall -4AN allen plug.
- NOTE: After running the SC, the oil level will lower due to oil filling the bearings. The proper level should be between the bottom of the sight glass and the middle.
- Change SC oil every season or 200 hours, only use **WHIPPLE SC OIL ONLY!!**

WHIPPLE SC OIL LEVEL

Fill to center of oil sight glass. 5.8 fl/oz. or 155cc.
DO NOT OVERFILL, WILL VOID WARRANTY!!

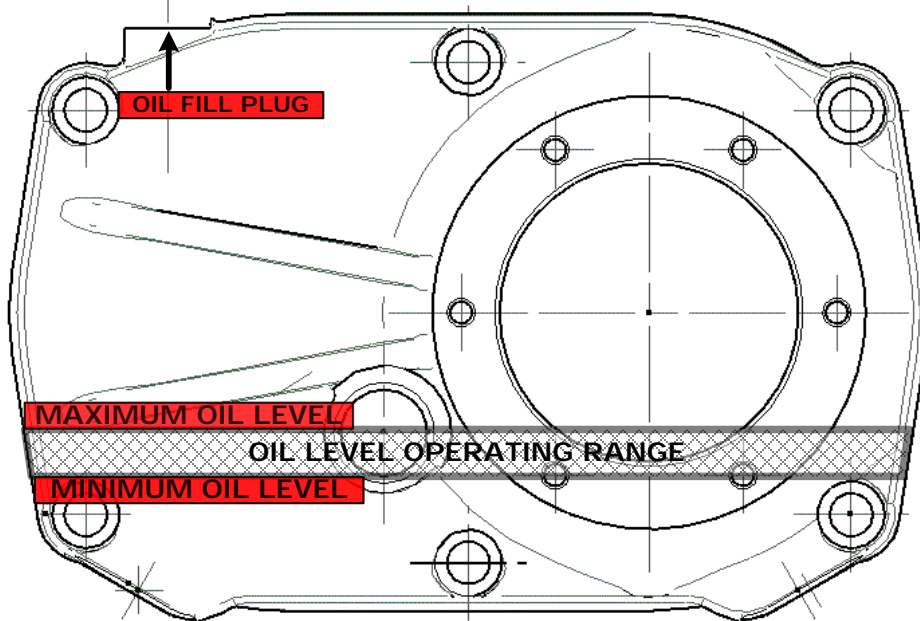

!! CAUTION !!

Severe damage to the compressor will occur if you overfill the supercharger front gear case.

62. Relocate the factory shifter bracket to the transom or stringer. In some cases, the wires may need to be extended.



63. Throttle linkage installation:

- Install supplied 1/4" linkage stud into anchor position and bell crank throttle arm. You may need to check linkage length to pick the appropriate hole.
- Install throttle linkage steel sleeve you removed from stock throttle linkage to "anchor" stud along with a 1/4" washer on both sides of the sleeve.
- Route linkage cable to the front starboard side of engine.
- Install factory throttle linkage anchor bolt into "L" adapter.
- Install factory throttle linkage bolt in throttle arm.
- Adjust linkage so that the linkage barely fits on the linkage bolt, so that the linkage is always being forced to its maximum closing position. You want to "preload" the linkage so the linkage slack is taken out and is forcing the throttle closed. This is very important to getting the motor to idle properly.
- Tighten all bolts, allens, etc. on throttle assembly.

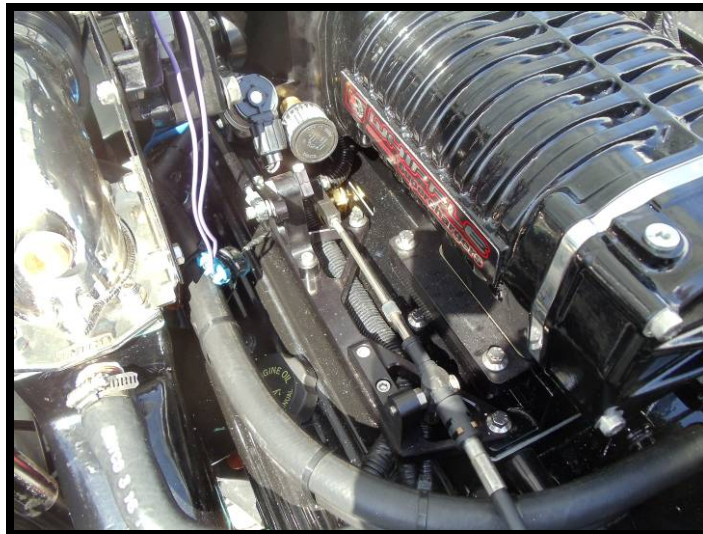

Whipple Charger Installations Instructions for Mercury 350/377 Mercury Engines

64. Verify that the linkage does not go over center at any time. Should be able to go back and forth 100% without binding.
65. Install the supplied 91-octane only decal in a visible location, preferably by the gas gauge.



66. Turn key to the on position and set fuel pressure to the following PSI (pump will prime for 4 seconds).

- 6.2MX MPI MODELS (including Reman motors) (all years) 45psi.**
- 350 MAG MPI MODELS (all years) 45psi.**

67. Adjust TPS voltage: **DO NOT START ENGINE WITHOUT SETTING!**

- The TPS sensor is located on the port side of the throttle body. The sensor is installed onto a billet adapter that has two socket head allen bolts holding it in place. The billet adapter is slotted to allow adjustment to the TPS sensor.
- With the key in the on position, with the TPS sensor connected, probe the blue wire (signal wire) in the TPS connector with a volt meter. The TPS sensor is a 0-5v sensor and needs to be in the .50v - .55v range. To adjust, loosen the allens holding the adapter on to the throttle body, rotate the billet adapter clockwise to raise the voltage, counter clockwise to lower the voltage. Once set, tighten allen bolts, turn ignition off for 5 seconds, turn ignition on, open the throttle to 100% and then close. Measure the TPS voltage again and make sure it is consistently returning to the same voltage.

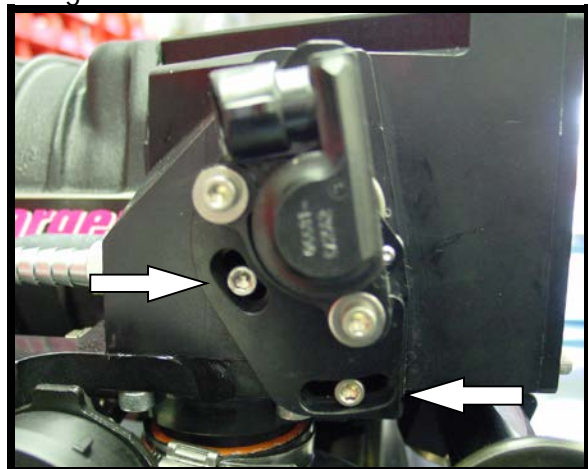
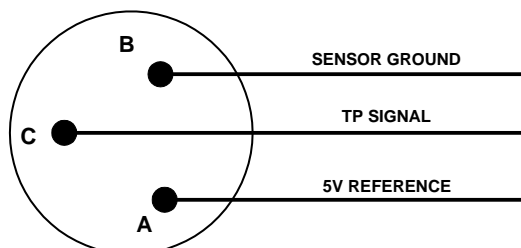

BEFORE STARTING THE ENGINE

MAKE SURE THE THROTTLE CABLE OPERATION IS CORRECT. WITH THE ENGINE OFF, MOVE THE THROTTLE A FEW TIMES TO FULL OPEN AND CLOSED POSITIONS. THERE SHOULD BE NO BINDING OR STICKING AND SHOULD OPERATE FREELY.

IDLE SPEED SETTING

68. Some motors may need an idle adjustment. First, you must understand the ECU has a desired idle speed that the motor is always going to try to achieve. The rpm idle speed should be 700 rpm once motor is up in the 120+ range of engine coolant temperature.

- On the starboard side of throttle body, there's the linkage arm that is pushed over a splined shaft. Behind this is the throttle stops, one for wide open throttle and one for idle, you can adjust this screw to raise the idle speed or lower the idle speed.
- As shown in the following figure, you must adjust the socket head allen to raise or lower the idle speed. Note that this is where the throttle stops in the relaxed or returned position. Turn clockwise to raise rpm (allows more air to enter engine), turn counter clockwise to lower rpm (decreases air into engine).

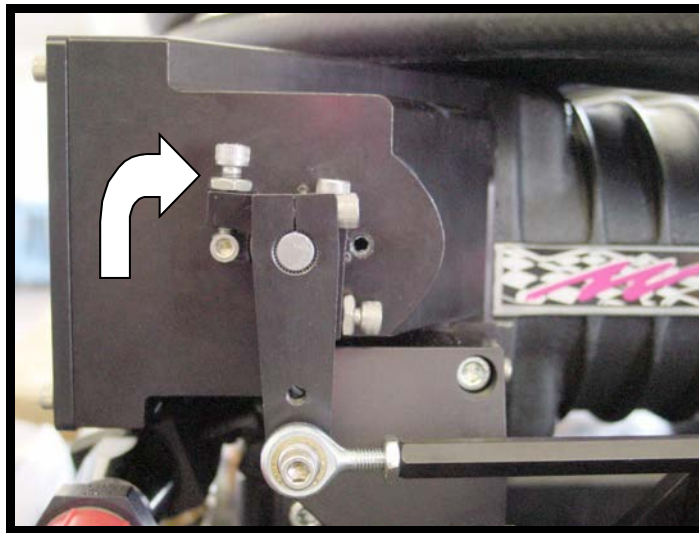

- After adjusting, verify that TPS voltage has not moved out of range, if it has, readjust only the sensor.

Engines that idle to high:

- This means either there's a vacuum leak, too much timing or there is too much air going by the throttle blades. To lower airflow at idle, take the set screw/throttle stop and lower it. This allows the throttle blade to close more when returned. Make small adjustments such as 1/8th turns. **NOTE: Don't forget to tighten locking nut after adjustment.**

Engines that idle to low:

- This means either there's not enough air being fed to engine or not enough timing. To increase airflow at idle, take the socket head allen bolt/throttle stop and raise it so when the throttle is in its relaxed position, it will be slightly open more. Make small adjustments such as 1/16th turns. **NOTE: Don't forget to tighten locking nut after adjustment.**

- If the engine is loping between 600-1000, open the blade). If the RPM is too high, you must close the blade (lower the voltage). If you do have a scanner, watch the IAC %. You want it to be between 5-25 counts. You must shut the motor off for 5 seconds to reset the IAC motor. If you do not have a scanner, you can adjust this setscrew until you see the motor idles around 700 on the tachometer, the motor should not hunt more than 100 RPM.
- Rev engine up past 2500 rpm and bring back at a rapid rate. The motor should not die, it should come back to the desired idle speed within 1-5 seconds. If it dies, then it needs more air so follow instructions for engines that idle too low.

Motors that idle high only after revving the engine or there are no more adjustments to be made:

- This means the TPS voltage is slightly off and that it does not return to its "Closed Loop Idle System." To fix this, you must loosen the TPS sensor (located on port side of throttle body) and push the bottom out towards the back of the boat. This will lower the TPS voltage. Tighten allens and try starting it again. You may want to use the scanner or a volt-meter (0-5volt sensor output) to watch the voltage come down. Ideal voltage should be in the range of 0.50 – 0.55 volts.

CRITICAL!!!

LAKE TEST POST-INSTALLATION CHECKLIST

After installing the Whipple supercharger kit it is imperative that the following checklist be performed. Failure to perform these simple tests may result in severe engine damage.

1. Make sure 91 octane or higher is in the vessel. If unsure, then drain the tank completely empty and fill with 91 or higher.
2. To measure boost, install a fitting in the intake manifold, there are 3 additional 1/8" NPT holes for boost readings.
3. Fuel pressure is the most critical parameter and must be checked during wide-open throttle operation. Install a quality fuel pressure gauge to the extra port at the fuel rail (1/8" NPT). Attach the fuel pressure gauge with a long enough hose so that it may be visible during operation. Under WOT, full boost, max rpm, the fuel pressure should be 50psi (+/- 2psi). This procedure takes two people – one to drive and the other to observe the gauge. Perform the test in a safe area. If it does not maintain fuel pressure, you must find the restriction, as this results in a lean air to fuel condition.
4. Intercooler water flow. The intercooler dump fitting should be passing a steady stream of water 1-2 feet past the thru-hull dump at high speeds.
5. To test manifold pressure, or to install a vacuum/boost gauge, there is an extra 1/8" port at the back of the intake manifold.

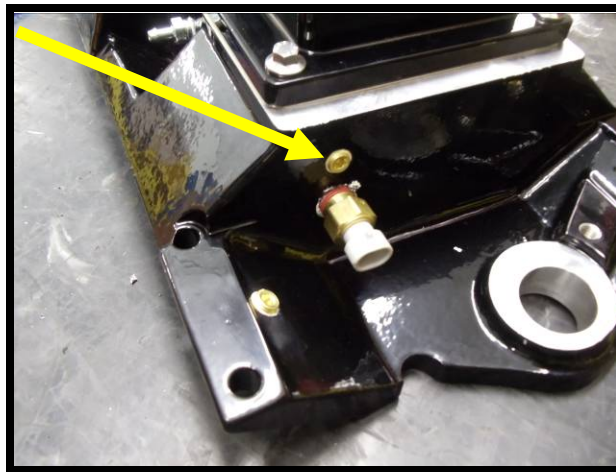

MAINTENANCE AND SERVICE

It is recommended that the following items be checked at normal service intervals.

1. Check supercharger oil every 10-15 hours of operation.
2. Change supercharger oil every 50 hours or every season, whichever comes first.
3. Check the supercharger/accessory drive belt. Adjust or replace as required.
4. Inspect and replace fuel filter every 50 hours.
5. Backflush intercooler once a season or every 50 hours, whichever comes first.
6. Replace spark plugs once a season or every 50 hours, whichever comes first.
7. Remove and clean stainless steel flame arrestor elements from Whipple throttle body every 25 hours.
8. Replace distributor cap, rotor and wires every season.

NEVER/DO NOT!!!

1. Never run octane less than 91.
2. Do not use octane booster, these are very hard on the spark plugs and only increase a few points. Example: 87 octane with octane booster, may raise a few "points" to 87.5, which is not acceptable.
3. Never operate engine if overheating.
4. Never operate engine in boost if water temp exceeds 150.
5. Never operate engine in boost if oil PSI falls below 20psi.
6. Do not operate engine in boost if fuel pressure falls below standard levels.
7. Do not design your own fuel system, the system is designed for use and installation as we specify.
8. Do not design your own water system, this system has been designed and tested to work according to our specifications.

DIAGNOSTIC INFORMATION

J-1 Circuits with MEFI 3

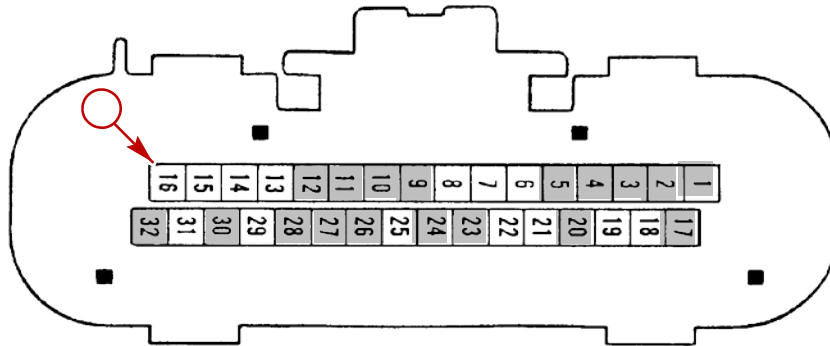

J-1 Front Pin 32 Pin Input Connector

a - Shaded Area Denotes Pin Connector Location Used On Terminal

Pin	Pin Function	CKT	Wire Color	Normal Voltage		DTC	Possible Symptoms
				Ignition ON	Engine Running		
J1-1	Injector Driver	467	DK BLU	B+	B+	None	Rough Idle, Lack Of Power, Stalling
J1-2	Ignition Coil	121	WHT	Not Usable	Not Usable	45	Rough Running, Poor Idle, Lack of Performance
J1-3	Ignition Control Ref. Low	453	RED/ BLK	0 (NOTE 5)	0 (NOTE 5)	None	Poor Performance
J1-4	ECM Ground	450	BLK	0 (NOTE 5)	0 (NOTE 5)	None	No Start
J1-5	ECM Ground	450	BLK	0 (NOTE 5)	0 (NOTE 5)	None	No Start
J1-9	MIL Lamp	419	BRN/ WHT	0 (NOTE 5)	0 (NOTE 5)	None	Lamp Inoperative
J1-10	Ignition Control Signal	423	WHT	0 (NOTE 5)	1.2V	42	Stall, Will Restart In Bypass Mode, Lack Of Power
J1-11	IAC "B" Low	443	GRN/ WHT	Not Usable	Not Usable	None	Rough Unstable or Incorrect Idle
J1-12	IAC "A" Low	442	BLU/ BLK	Not Usable	Not Usable	None	Rough Unstable or Incorrect Idle
J1-17	Injector Driver	468	DK GRN	B+	B+	None	Rough Idle, Lack Of Power, Stall
J1-20	ECM Ground	450	BLK	0 (NOTE 5)	0 (NOTE 5)	None	Rough Running, Poor Idle, Lack Of Performance

J-1 Circuits with MEFI 3 (Continued)

Pin	Pin Function	CKT	Wire Color	Normal Voltage		DTC	Possible Symptoms
				Ignition ON	Engine Running		
J1-23	Fuel Pump Relay Driver	465	DK GRN/WHT	0 (NOTES 1&5)	B+	None	No Start
J1-24	Ignition Control Bypass	424	TAN/BLK	0 (NOTE 5)	4.5V	42	Lack Of Power, Fixed Timing
J1-26	Audio Warning Horn	29	DK GRN	–	–	None	–
J1-27	IAC “B” Low	444	GRN/BLK	Not Usable	Not Usable	None	Rough Unstable or Incorrect Idle
J1-28	IAC “A” High	441	BLU/WHT	Not Usable	Not Usable	None	Rough Unstable or Incorrect Idle
J1-30	Knock Sensor Signal	496	BLU	–	–	43, 44	Poor Fuel Economy, Poor Performance Detonation
J1-32	Serial Data	461	ORN	5V	5V	None	No Serial Data

J-2 Circuits with MEFI 3

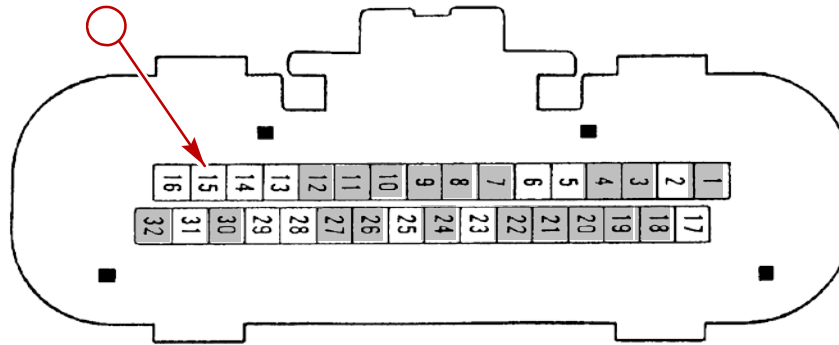

J-2 Rear 32 Pin Output Connector

a - Shaded Area Denotes Pin Connector Location Used On Terminal

Pin	Pin Function	CKT	Wire Color	Normal Voltage		DTC	Possible Symptoms
				Ignition ON	Engine Running		
J2-1	Battery	440	ORN	B+	B+	None	No Start
J2-3	Sensor Ground	813	BLK	0 (NOTE 5)	0 (NOTE 5)	21,23	High Idle, Rough Idle, Poor Performance Exhaust Odor
J2-4	TP 5V Power	416	GRY	5V	5V	21	Lack Of Power, Idle High
J2-7	Discrete Switch	114	BLU	-	-	None	-
J2-8	Discrete Switch	585	TAN/ WHT	-	-	None	-
J2-9	Shift Switch	923	WHT	0	0	None	Incorrect Idle
J2-10	Ignition Control Ref. High	430	PUR/ WHT	5V	1.6V	None	No Restart
J2-11	ECT Signal	410	YEL	1.95V (NOTE 2)	1.95V (NOTE 2)	14	Poor Performance, Exhaust Odor, Rough Idle rpm Reduction
J2-12	Fuel Pressure	475	GRN	3V	3V	61, 62	-
J2-18	MAP Ground	814	BLK	0 (NOTE 5)	0 (NOTE 5)	33	Lack Of Performance, Exhaust Odor, Stall
J2-19	MAP 5V Reference	416	GRY	5V	5V	33	Lack Of Power, Surge, Rough Idle, Exhaust Odor
J2-20	Discrete Switch	208	BRN	-	-	-	-

J-2 Circuits with MEFI 3 (Continued)

Pin	Pin Function	CKT	Wire Color	Normal Voltage		DTC	Possible Symptoms
				Ignition ON	Engine Running		
J2-21	Master/Slave	916	YEL	B+	B+	None	Lack Of Data From Other Engine (Dual Engine Only)
J2-22	Diagnostic Test	451	BLK/WHT	B+	B+	None	Incorrect Idle, Poor Performance
J2-24	Discrete Switch	906	TAN/WHT	–	–	None	
J2-26	TP Signal	417	DK BLU	.62V (NOTE 4)	.62V (NOTE 4)	21	Poor Performance And Acceleration, Incorrect Idle
J2-27	Map Signal	432	LT GRN	4.9V	1.46V (NOTE 3)	33	Poor Performance, Surge, Poor Fuel Economy, Exhaust Odor
J2-30	IAT Sensor	472	TAN	5V	(NOTE 2)	23	Poor Fuel Economy, Exhaust Odor
J2-32	Ignition Fused	439	PNK	B+	B+	None	No Start

MEFI 3

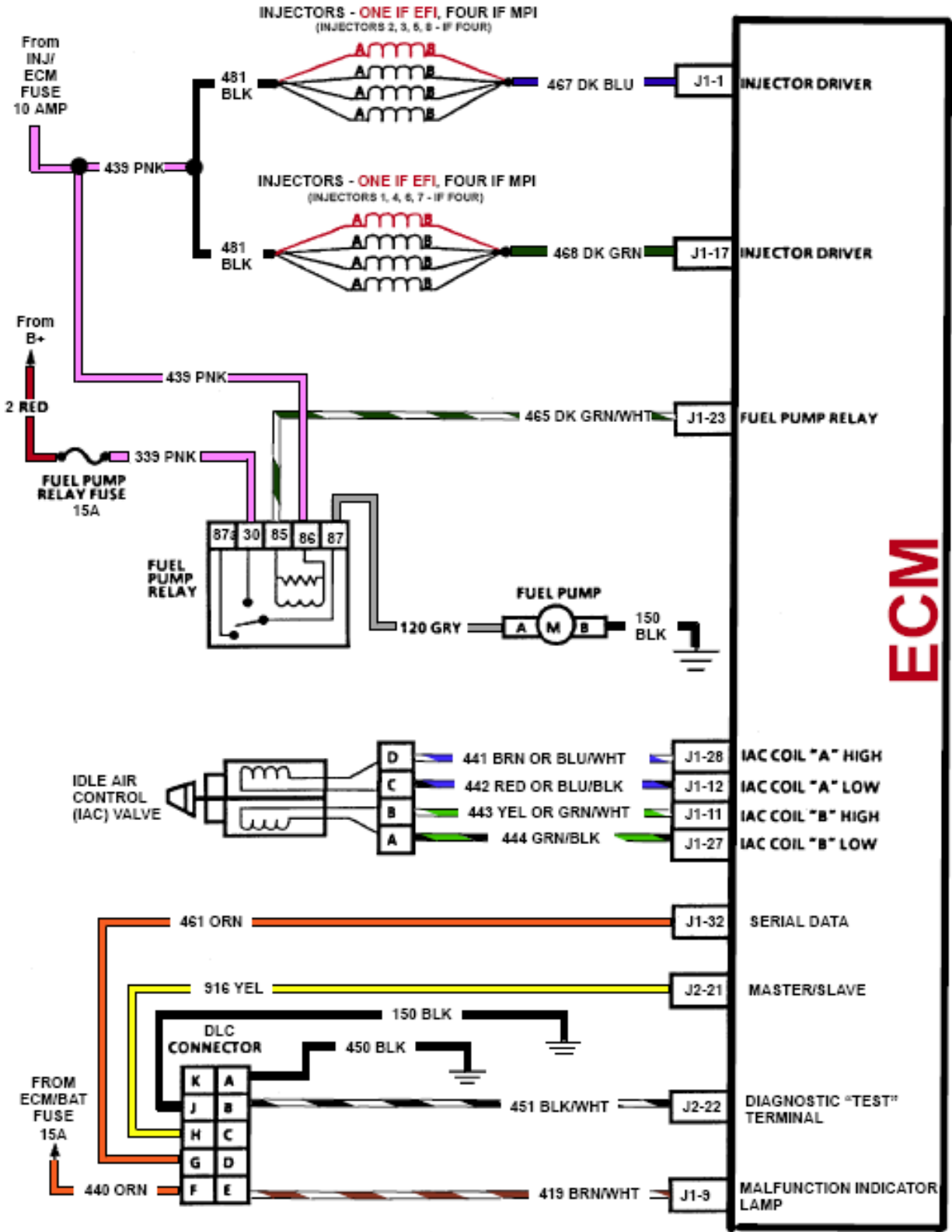

MEFI 3 (Continued)

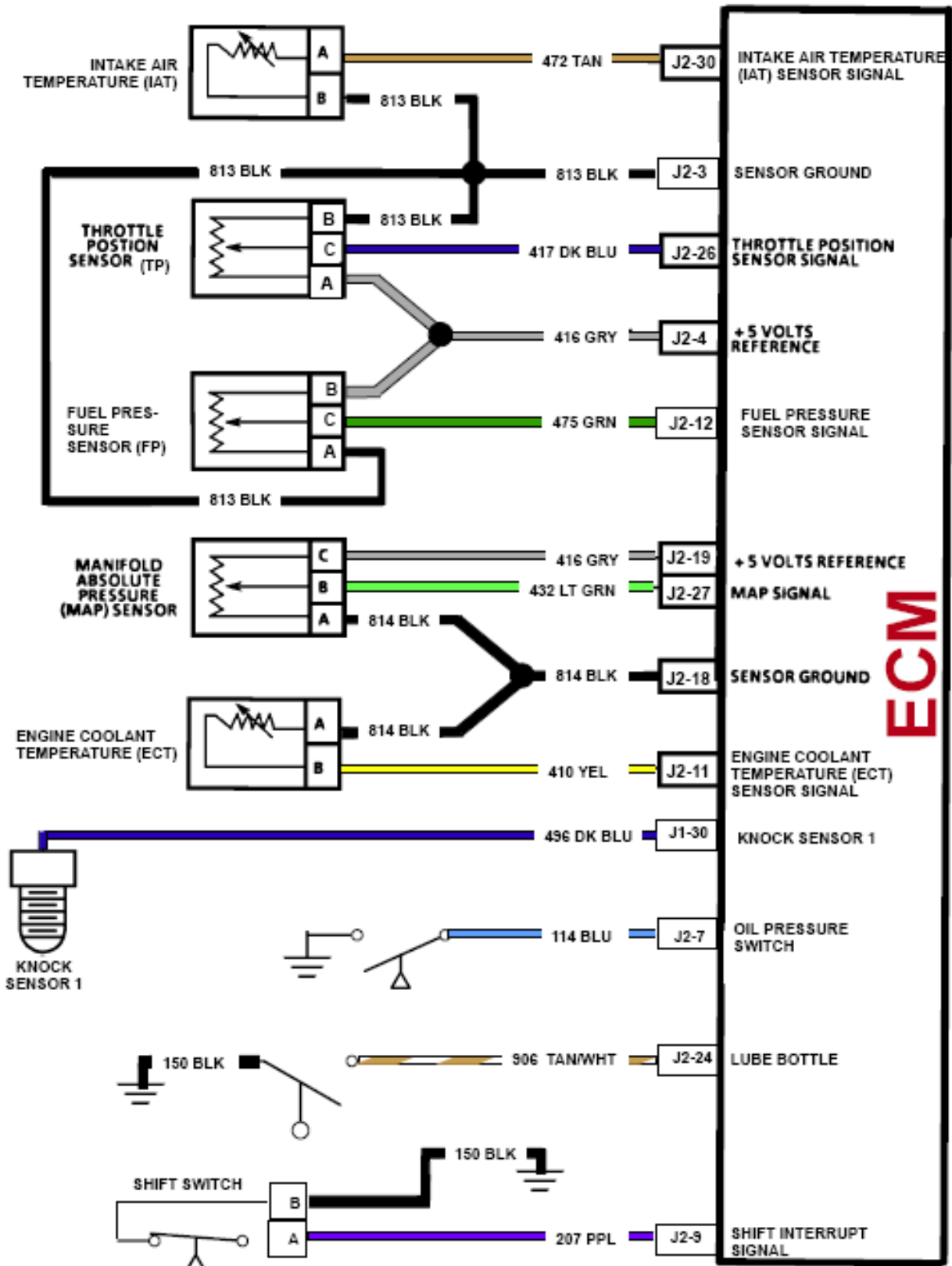

MEFI 3 With Mercury Distributor

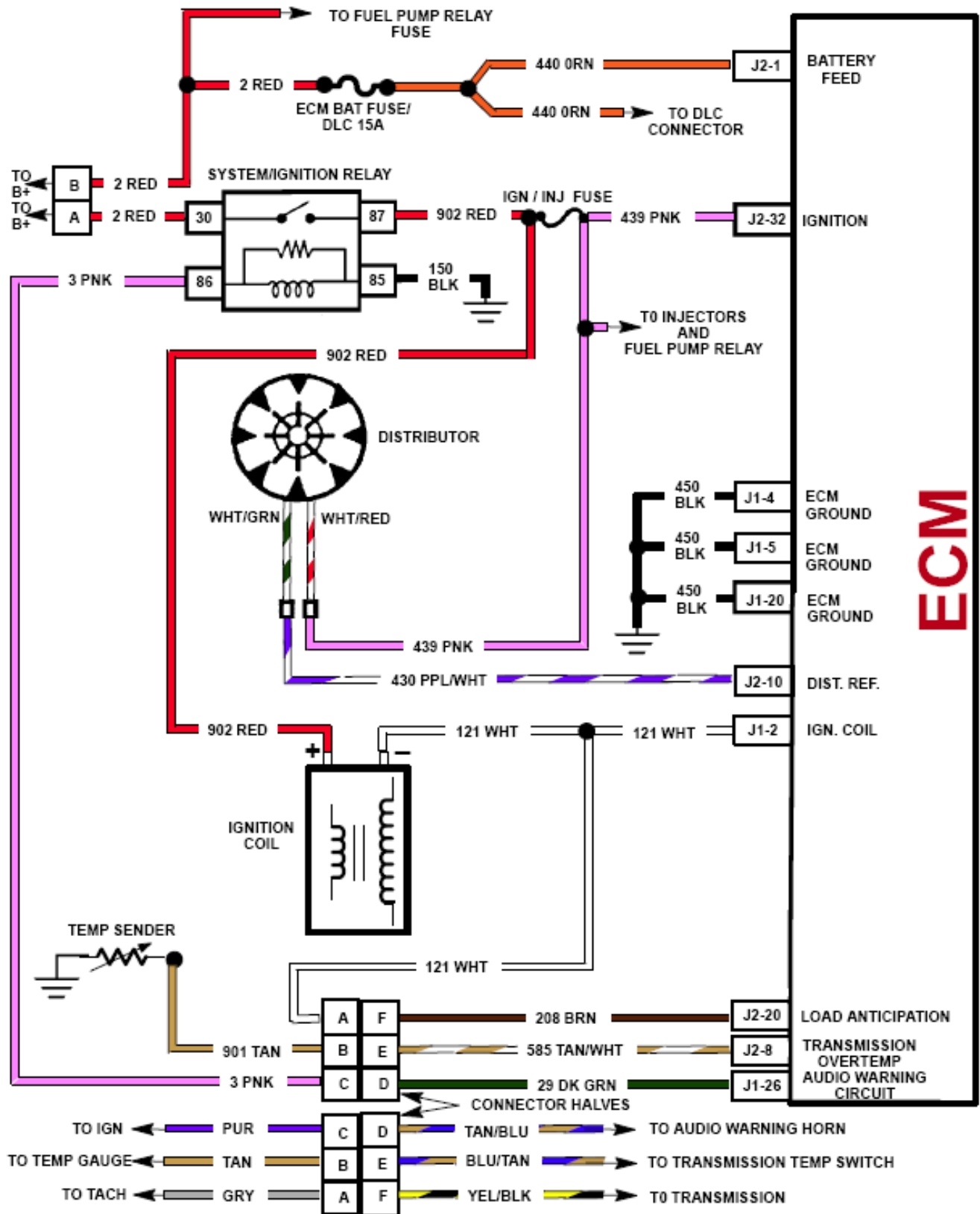

MEFI 3 With GM EST Distributor

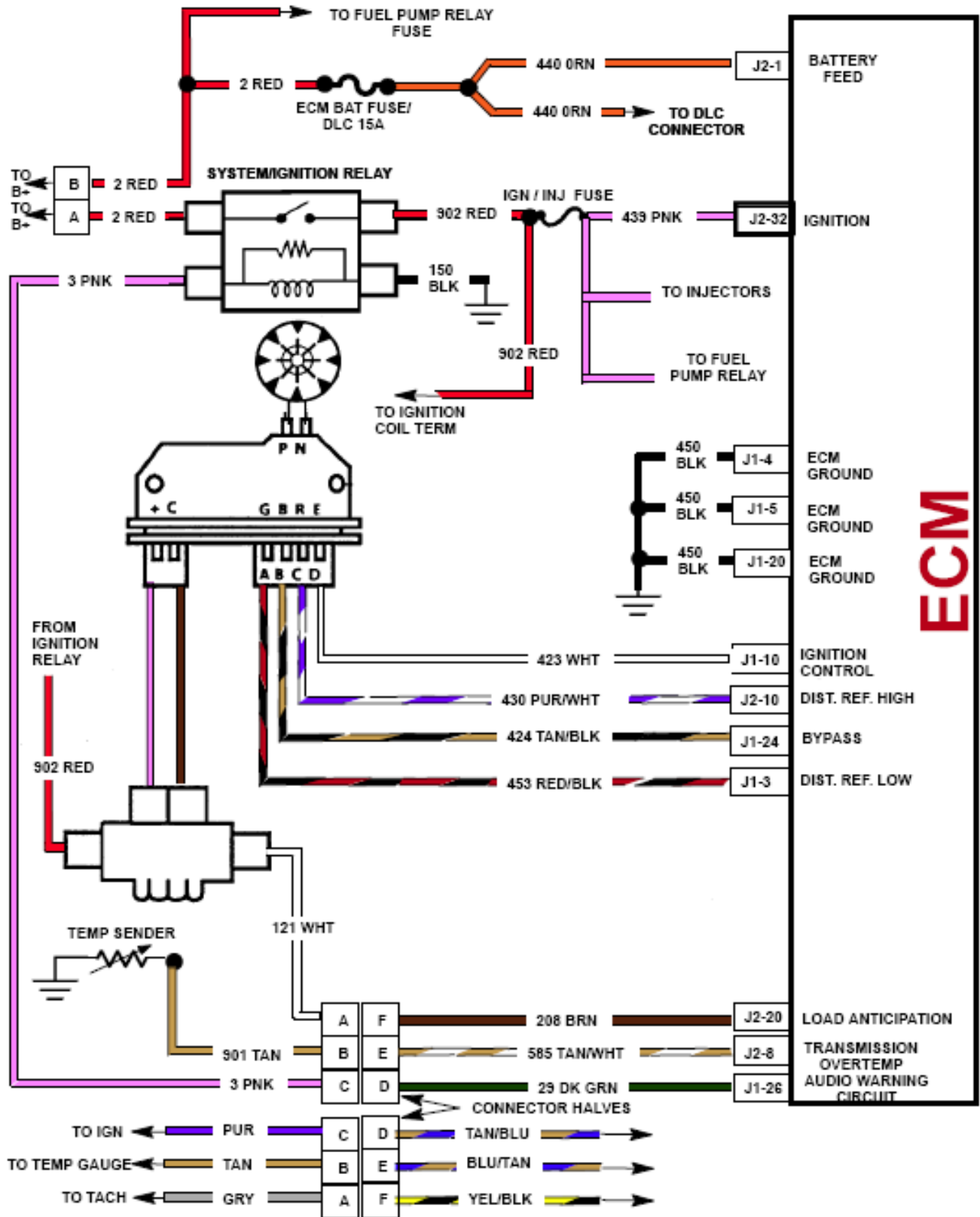
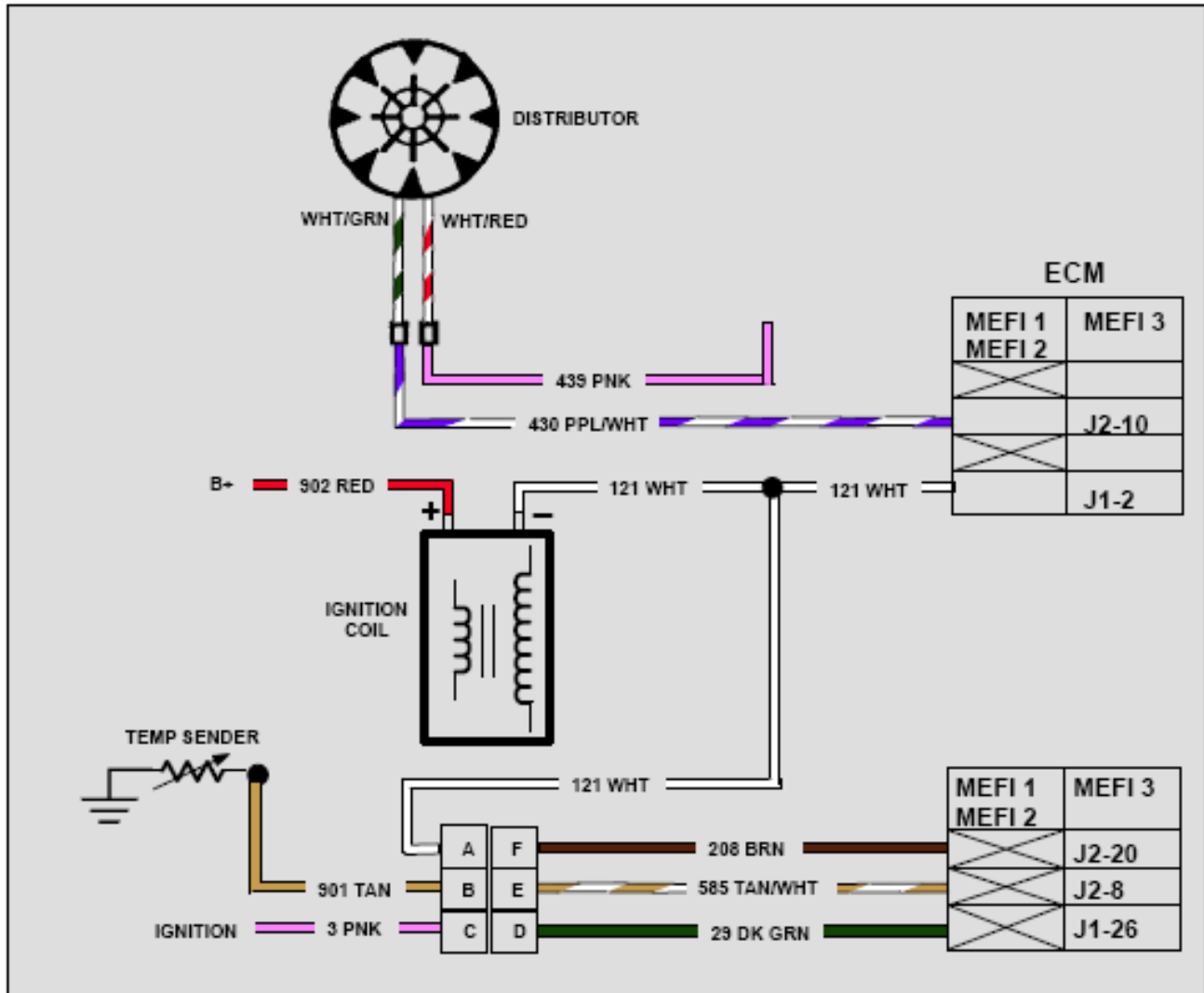

Chart A-7 (2 of 6): Ignition System Check

MEFI 3 (EXCEPT BLACK SCORPION)



CIRCUIT DESCRIPTION MEFI 3:

The Distributor Ignition (DI) system receives supply voltage from the system relay through CKT 902 to the ignition coil positive (+) connector.

Inside the distributor, the pick-up sensor will produce a voltage signal for cylinder spark. The voltage signals are processed in the ECM. The ECM will decide if the engine is in the cranking or running mode and adjust timing accordingly.

The ECM will send a signal to the ignition coil negative (-) terminal through CKT 121. The signal will trigger the coil creating secondary spark to be produced. This secondary spark is sent to the distributor by a high tension lead.

IMPORTANT INFORMATION

SPEEDS

Due to the variance in boats and combinations, it's impossible to guarantee the speed increases or stability of the boat with the increased power and larger propellers. You must use your discretion for proper boating safety. In most applications, you will need 4 pitches larger propellers to maintain proper rpm ranges when supercharged.

BOOST LEVELS

All Whipple kits are shipped with approximately 5-6psi for stock engines (@ sea level). Additional pulley's are available for lower and higher boost levels, the supplied ECM has been calibrated for 4-10lbs of boost, sea level to 6000 feet elevation. Higher boost levels must run higher octane levels such as 100LL, 104, 110, 116, etc. Whipple does not recommend exceeding 8psi of boost on stock engines at anytime.

MUFFLERS

Many states are now mandating lower DB levels and some must use mufflers to reach those levels. There are many different systems out there, and we cannot test them all. It's very important that you measure your boost level in the engine before and after the muffler s installed. If the mufflers are limiting flow, you will see an increase in boost. While the effective power may be the same, this can increase cylinder temperatures to critical levels and should be avoided. Whipple has tested Gibson and Imco muffler tips and have found these to be very effective at lowering the DB level while not limiting exhaust flow. Again, there are many different systems out there so some testing may be required.

EXHAUST HEADERS

The stock cast iron headers work with stock boost levels. Upgraded exhaust systems such as Imco Power flows, Eddie Marine, Lightning and CMI will help performance and reliability by lowering the back pressure, thus lowering cylinder temps.

FUEL SYSTEM

The Whipple fuel system (flow) needs no additional changes for power levels up to 600HP. After 600HP, the supplied fuel pump will reach it's maximum capacity and will need to be replaced to a larger size, consequently, to reach this power level, internal engine modifications will be required. Consult your authorized Whipple dealer for more information.

AIR FUEL RATIO

Air fuel ratio is the measurement of the amount of air and fuel being burned during the combustion process. In order for you to monitor the air fuel ratio, you must have a 18mm stainless steel bung welded into the collector of the header or tailpipe (aftermarket exhaust only) or a billet spacer between the riser and exhaust manifold (stock). With aftermarket systems, it must be within 2" of the sealing flange or in the tail pipe, approx. 2" away from the sealing flange. This must be double welded to insure that there are no water leaks. There are many companies that can do this for you, CMI, Teague Custom Marine, Imco, Eddie Marine, Stellings, etc.

There are currently many different air fuel-monitoring systems and accuracy is not always guaranteed. Wide band oxygen sensors vary over time and deteriorate with uses of leaded gasoline. Whipple only uses Horiba wide band analyzers and UEGO 6-wire sensors, the most accurate available. Our sensors are checked after every use and transfer functions are changed every time so make sure you're using an accurate meter. There are currently quite a few meters on the market that do the job pretty well, some good low cost a/f meter at www.aemelectronics.com, www.ngk.com, www.innovatemotorsports.com, www.fuelairspark.com, www.autometer.com.

The Whipple supplied calibration has a conservative tune where WOT should be around 11.50-11.85:1. Idle A/F will vary depending on engine temp, but this should roughly be 13:1. Cruising, mid level rpms and throttle ranges should come to 13:1. As boost increases, the air fuel will get progressively richer. Adjusting the static pressure will either richen or lean the entire curve, this should only be done with an accurate a/f meter. Whipple has found that 12.6:1 is approx. the best a/f for power (at WOT) but is very dangerous on pump gas and should only be run that way on custom, purpose built motors or on race gas. Be very careful, too lean of an air fuel ratio increase cylinder temps and increase the chance of detonation, which is detrimental to engine life.

FUEL OCTANE

Never run a fuel octane that is below 91octane, (RON+MON)/2. It is recommended, when available, to run 92-94 octane.

Whipple Charger Installations Instructions for Mercury 350/377 Mercury Engines

Never mix mid level (below 91) with 91+, this is very dangerous and can cause severe engine damage. Do not attempt to increase octane ratings with octane boosters, these are very hard on spark plugs and many brands do very little to the actual octane rating. For emergence situations, the best octane booster found to date is made by NOS, the "Off-road" formula has shown to increase the octane rating nearly 2.5 points when mixed at it's most concentrated level. Again, this is very hard on spark plugs so constant use will require increased spark plug maintenance.

INTERCOOLER WATER FLOW

The intercooler does not need water being run through it at all times. It's main function is to remove the heat from the compression of air, therefore you should always have water flow when your in boost to help reduce the manifold air temperature. The intercooler can withstand 50psi and becomes more effective with more water flow, therefore it's ideal to pump as much water through the intercooler as possible, giving you the coolest discharge temps.

The intercooler should be flushed every time its run in salt or brackish water and should be back-flushed every 50 hours to ensure proper cooling.

FUEL LEVEL

Never operate at WOT when the vessel fuel levels are below a ¼ tank. Low fuel levels could cause the fuel pump to cavitate and you'll have fuel flow spikes resulting in lean conditions and consequently detonation.



LIMITED WARRANTY

All merchandise manufactured by Whipple Industries is fully warranted against defects in workmanship and materials to the original purchaser of the Whipple Supercharger System. The limited warranty must be signed, dated and returned to Whipple Industries within 14 days of the purchase date accompanied by a copy of the original sales invoice.

If an item is suspected of being defective, return it to Whipple Industries for inspection after obtaining the proper Return Authorization Number. If an item is determined to be defective, we will repair or replace it at our discretion within a period of one year from the shipping date on your invoice.

Whipple Industries Inc. limited warranty specifically does not apply to products which have been (a) modified or altered in any way, (b) subjected to adverse conditions such as misuse, neglect, accident, improper installation or adjustment, dirt, or other contaminants, water, corrosion or faulty repair; or (c) used in other than those specifically recommended by Whipple Industries Inc. All products designed for off-road use are considered racing parts and carry no warranty, either expressed or implied, as we have no control over how they are used.

On warranty items, repair/replacements will be limited to parts manufactured by Whipple Industries and will not include claims for labor or inconvenience. All other merchandise distributed by Whipple Industries is warranted in accordance with the respective manufacturer's own terms of warranty. This warranty is expressly made in lieu of any and all other warranties expressed or implied, including the warranties of merchantability and fitness.

Whipple Industries will not be responsible for any other expenses incurred by the customer under the terms of this warranty, nor shall it be responsible for any damages either consequential, special, contingent, expenses or injury arising directly or indirectly from the use of these products.

Whipple Industries reserves the right to determine whether the terms of the warranty, set out above, have been properly complied with. In the event that the terms are not complied with, Whipple Industries shall be under no obligation to honor this warranty. By signing this form, you understand and agree to the terms above.

NAME (Print) _____	ADDRESS _____
SIGNATURE _____	CITY _____ STATE _____ ZIP _____
DATE _____	PHONE _____
SC SERIAL # _____ (Found on compressor bearing plate)	EMAIL _____ (Optional)
VIN OR VESSEL # _____	