

Whipple Superchargers 454/502 Magnum TBI Stage 1 and 2 Installation Instructions



WHIPPLE SUPERCHARGERS
3292 NORTH WEBER AVE
FRESNO, CA 93722
TEL 559.442.1261
FAX 559.442.4153

www.whipplesuperchargers.com

A color PDF of this manual is available, email
tech@whipplesuperchargers.com for a copy

PREMIUM FUEL ONLY (91 OCTANE OR BETTER ALWAYS) RON+MON/2

**Version B1R3
Last Updated June 30th, 2016**

MUST KNOW INFORMATION!!

-EVERYBODY READ!!-

WATER FLOW – WATER FLOW – WATER FLOW

As of May 2002, Mercury Racing issued a service bulletin (attached to instructions) regarding engine water block pressure. In this bulletin, it's clear that Mercury Racing requires a minimum of 20-30lbs. of engine water pressure at wide-open throttle (WOT). If this pressure is not achieved or not maintained, you can have catastrophic engine failure of many types.

This leads us to your new supercharged engine. You're no longer running a thermostat in the engine, which was the largest water restriction in the stock system. Now, the largest restriction is the engine itself, this means pressure is only increased by flow in this given application. Because you are taking your stock engine and increasing the cylinder pressure for more peak power, to insure reliability, you need **more** water to keep the engine cool and at the same time, you need **more** water pressure to keep steam pockets from developing in your engine. With this in mind, you want a minimum of 25lpsi of block pressure @ WOT, maximum 40psi @ WOT. If you do not have this pressure, you may hurt your engine.

Whipple Superchargers has provided a stainless restrictor for the thermostat housing that will restrict the flow like a thermostat, but pressure still must be checked, as this may be too much restriction (ideally) or not enough (means you need more). With this information in mind, you must understand, you must have more flow as well as pressure, if you restrict the outlet water too much and don't have proper flow, you will heat the engine up, still develop steam pockets and it could lead to engine failure.

- Ideally, the intercooler should be fed from a separate source. The intercooler does not need constant water flow at slow speeds. This means a separate pickup can be installed solely for the intercooler.
- You can run the intercooler off the drive side draft inlets, but never the engine.
- Mercury dual style water pickups do not let more water in, in fact, they have less water flow. Always block off the side draft inlets if your boat uses them on this dual style drives.
- Never run the engine off side draft inlets in the drive, never!
- If you have a stepped bottom or high "X" dimension, water flow may be very low at high speeds and caution must be taken.
- Test block pressure at various trim angles and in turns.
- Lower boost and or timing does not mean you're safer with less water, if steam develops, the engine will fail regardless, it needs pressure to push the steam out.

WATER FLOW – WATER FLOW – WATER FLOW

WHIPPLE CHARGER INSTALLATION INSTRUCTIONS

This product is intended for use on **STOCK, UNMODIFIED, WELL-MAINTAINED ENGINES**. Installation on a worn-out or modified engine is not recommended and could result in failure of the engine or the supercharger. It is recommended to perform a compression test of all cylinders, and perform a cylinder pressure leak down procedure. This will indicate the condition of the engine for reference. Whipple also highly recommends water block pressure and fuel pressure gauges for constant monitoring during operation.

YOU MUST SEND YOUR ECU IN FOR REPROGRAMMING TO WORK WITH THE WHIPPLE SUPERCHARGER SYSTEM. THERE ARE REPLACEMENT ECU'S AVAILABLE. ACCOMPANY EACH COMPUTER WITH NAME, SHIPPING INFORMATION, CONTACT INFO, BOAT INFO AND IF ANY MODIFICATIONS HAVE BEEN MADE TO THE ENGINE. SEND FACTORY ECU TO:

**WHIPPLE SUPERCHARGERS
ATTENTION: MARINE ECU RECAL DEPARTMENT
3292 N. WEBER
FRESNO, CA 93722
559.442.1261**

****NOTICE: Installation of Whipple Supercharger products signifies that you have read this document and have agreed to the terms stated within.**

It is the purchaser's responsibility to follow all installation instruction guidelines and safety procedures supplied with the product as it is received by the purchaser to determine the compatibility of the product with the vessel or the device the purchaser intends to install the product on.

Whipple Supercharger assumes no responsibility for damages occurring from accident, misuse, abuse, improper installation, improper operation, lack of reasonable care, or all previously stated reasons resulting from incompatibility with other manufacturers' products.

There are no warranties expressed, implied, for merchantability or fitness for engine failure, parts failure, any type of damage to vessel in any way, or reimbursement for labor or inconvenience.

For best performance and continued reliability the following are **MANDATORY**.

1. USE ONLY PREMIUM GRADE FUEL (91 OCTANE OR BETTER).
2. ALWAYS LISTEN FOR ANY SIGN OF ENGINE KNOCKING, IF PRESENT DISCONTINUE USE IMMEDIATELY.
3. DO NOT OPERATE ENGINE IN BOOST IF THE FUEL PRESSURE IS BELOW THE PRESSURE SPECIFIED BY WHIPPLE INDUSTRIES.
4. NEVER CHANGE COMPUTER CALIBRATION (Engine fuel, ignition timing, or the RPM limiter, nothing)! THIS COMPLETE SUPERCHARGER SYSTEM IS DESIGNED AND ENGINEERED TO MAXIMUM PERFORMANCE FROM THE WHIPPLE CALIBRATION. MODIFICATIONS MAY CAUSE SERIOUS DAMAGE TO THE ENGINE.

Whipple Charger Installations Instructions for Mercury 454/502 Magnum Engines

WARNING! The most important precaution you must take with the WHIPPLE CHARGER is **cleanliness**. This supercharger is a high quality, close tolerance compressor that cannot be subjected to dirt or any type of foreign material. Foreign material entering the supercharger will automatically void all warranties. DO NOT remove the protective seal on the supercharger prior to installation.

GENERAL INFORMATION

Run the engine before beginning installation of the kit until it is as close as possible to empty. Make sure that fuel tank does not have old gasoline, and contains only fuel that is 91 octane or better, before installing supercharger kit. If the octane of the fuel in the tank is old or unknown, **drain the tank until empty and fill with 91-octane premium fuel**.

You will be required to disconnect a few wiring connectors. It may be helpful to tag the wires for future reference.

RECOMMENDED PREPERATION FOR INSTALL

It's highly recommended that if you have more than one year on your engine, you should replace the factory plugs, making sure to gap to .035". You should also change the rotor, cap and spark plug wires. This will insure no ignition related problems.

TOOLS RECOMMENDED

The following tools are required to complete the installation of this supercharger kit. Metric socket set, standard socket set, screwdrivers, torx head sockets, standard and metric end wrenches, standard and metric Allen wrenches, Loctite™, Teflon tape or thread sealant, electric or battery operated drill motor, various hole saws, electrical tape, wire crimpers or solder iron, mechanical water pressure gauge, 0-60 lb. Mechanical fuel pressure gauge with line kit and a torque wrench.

SYSTEM PERFORMANCE INFORMATION

A Mercruiser scanner is an electronic tool used to display various engine parameters. This scanner can be installed and monitor all engine parameters while the boat is being operated. Some of these are items are: RPM, TPS volts, KNOCK RETARD, COOLANT temp, IAC counts, and any TROUBLE CODES. You can also put the engine in the set timing mode. You can purchase this scanner at Whipple Industries for \$600.

1. TPS Voltage Setting- Before starting your engine, you must set the TPS voltage utilizing a MerCruiser scan tool or a standard 0-5v volt meter. The proper TPS voltage is between .50 - .55 volts. The TPS is a 5v sensor. The blue wire is the signal wire.

2. Idle speed setting- Your modified ECU has a "desired" idle speed that varies with engine temp. The engine should idle at approx. 800rpm @ 75° and 750rpm @ 100°. The ECU will modify both spark timing and the IAC position (counts). These numbers will constantly vary to maintain a smooth idle in and out of gear. If you have a scan tool, timing should bounce in the positive range, approx. 0-16, if it's constantly lower, it needs more air. If it's constantly higher (in neutral), then it needs less air. For the IAC counts, 150 is max wide open meaning that its allowing as much air into the system as possible,

Whipple Charger Installations Instructions for Mercury 454/502 Magnum Engines

while 0 counts means the IAC is closed, it is not allowing air into the system. If the counts are too low, adjust the closed throttle stop to close the throttle. If the counts are too high, adjust the throttle to open more. Although this number will move, in neutral, you want it to start high when engine fires and then count down to 0-40 counts. This will allow it to open to max when engine is shifted into gear. *Note: The engine must be turned off for 5 seconds and re-started to properly reset the learning of the IAC system.*

3. Check cooling system water pressure. The cooling system must be able to operate efficiently. Optimal performance and reliability will be gained if an external pick-up is installed for the Whipple Intercooler water. To check the performance of your cooling system, install a 0-50psi. pressure gauge on the water drain plug located on the bottom center of the block. The idle pressure may read 0-3psi. and full speed/RPM may read over 30psi. The minimum pressure allowed, for proper engine cooling, is 30psi at WOT. 40psi should be the maximum, if exceeded, please contact Whipple Industries. The reading should be obtained at high speed and high RPM. If the pressure is lower, another water pickup must be installed. Consult with Whipple Industries for recommendations. The Whipple intercooler will take water away from the engine if the water is teed from the stock system, so block pressure must be checked before and after.

4. Supercharger By-pass system. The supercharger is installed with a by-pass system. This allows the supercharger to operate at higher efficiency under vacuum operation. It is advised to verify the operation of the bypass valve. At idle and low engine loads, the bypass will be open. At higher loads (engine in boost) the bypass will be closed. As the throttle is opened quickly the bypass valve will close momentarily. This verifies the bypass will close and is functioning.

COMMON ABBREVIATIONS

SERP	Serpentine Belt systems
VBELT	V-belt accessories
ECT	Engine Coolant Temperature
IAT	Inlet Air Temperature
IAC	Idle Air Control
TPS	Throttle Position Sensor
MAP	Manifold Absolute Pressure
PCV	Positive Crankcase Ventilation

STEP-BY-STEP INSTALLATION INSTRUCTIONS

1. Disconnect the battery power by selecting the disconnect mode on the battery switch or removing the ground cable from all batteries.
2. Removal of stock parts:



(SERP) Loosen the stock adjustable idler nut to release tension of belt, remove the stock belt.

Whipple Charger Installations Instructions for Mercury 454/502 Magnum Engines

- (VBELT) Loosen accessories and remove factory v-belts.
- Remove the factory crank pulley and clean the front surface, the new SC crank pulley will mount to the surface of this later.
- Unplug factory electrical plugs: Idle Air Control connector, Inlet Air Temp connector, both Engine Coolant Temp connectors, Manifold Absolute Pressure connector, both distributor connectors.
- Remove stock throttle linkage and throttle body (throttle cable bolt and IAC motor) and flame arrestor.
- Remove factory shift cable bracket and mount on transom.
- Loosen the belt tensioner holding nut. Release the tension on the Poly-V belt and remove belt.
- Remove the self-locking nut and washer holding throttle cable to the throttle shaft and washer.
- Install stock IAC motor on new throttle body with stock o-rings and stock torx.
- Remove PCV valve and hose from intake manifold/valve cover.
- Remove the distributor. **Note:** It helps to mark the position of the distributor before removal so it can be stabbed much closer to 8 degrees. You can take the distributor cap off, crank engine over until pointer faces directly forward.
- Remove MerCruiser fuel lines from stock fuel filter assembly (leave your factory line routed to filter from tank).
- Remove factory fuel lines and unplug factory fuel pump. Leave cool fuel unit in place.
- Inspect factory fuel line from tank. Make sure there are no restrictions such as check valves, tight bends or anything smaller than 3/8" ID. Remove or replace any restrictions found.
- Remove thermostat housing and all it's connecting hoses.
- Remove entire intake manifold, both bottom and top assembly. Note: Must unplug all injector connectors before removing and pull away from fuel rail.
- Push factory-wiring harness to backside of motor so it's out of the way.
- Remove stock sensors from intake such as intake air temp sensor (located above #7 runner on intake) and 2 coolant temp senders (gauge and ECU).
- Remove stock circulating water pump from block and all of it's connecting hoses.

Whipple Charger Installations Instructions for Mercury 454/502 Magnum Engines

- (SERP) Remove stock adjustable idler support bracket from engine (this requires loosening of other brackets, reinstall them when done removing idler bracket).
- (VBELT) Remove mechanical fuel pump from sea pump assembly and install supplied fuel pump block off plate with the 3/8" x 1/2" socket head allens.
- Separate the intake manifold from the intercooler/SC assembly by removing the 8 3/8" hex bolts.

3. Install factory sensors:

- Install stock coolant temp sensors in new intake manifold (gauge portside), front of intake manifold.
- Install factory inlet air temp sensor into open 3/8" NPT hole in rear/port side of intake manifold (with pipe sealant on threads).



4. Intercooler and engine block water dump fittings: **DO NOT RESTRICT OUTLET**

- Find visible location for both dumps above the water line.
- Mark your spots on the boat, and drill a hole using a hole saw.
- Apply marine type silicone to exposed wood and fiberglass as well as the back of thru hull fittings.
- While holding thru-hull fitting (do not let it rotate) on outside of boat, install the supplied aluminum nut and tighten. Do the same for both thru-hull fittings.
- Apply thread sealant to threads of supplied 1/4" tee's male thread. Install tee fitting into thru-hull dump fitting that is tapped 1/4" NPT. Install the 2 1/4" 90 degree barbed fittings (apply thread sealant) into female ends of tee fitting.

Whipple Charger Installations Instructions for Mercury 454/502 Magnum Engines

- Install the brass -12 push lock fitting on to thru fitting with flared end. Make sure to hold thru-hull fitting in place when tightening.
- Once tightened, wipe the excess silicone off and let the silicone dry.

5. Intake manifold installation:

- Clean intake manifold and cylinder head surface.
- ➔ **NOTE.** Apply thick bead of RTV silicone around all 4 water passages on cylinder heads.
- ➔ **NOTE.** Mark and cut the intake gaskets to clear the galley pan mounts if required. **See figure.**

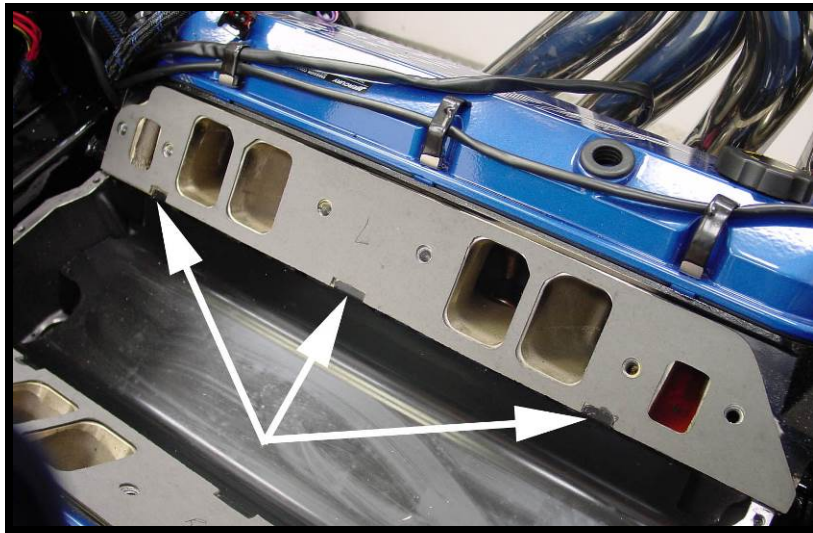

- ➔ **NOTE.** Apply a thick bead of black RTV silicone on the cylinder head water passages to insure sealing.
- Install new supplied intake gasket to cylinder head.
- ➔ **NOTE.** Apply a thick bead of black RTV silicone on the intake gaskets around the water passages to insure sealing around the water passages.
- ➔ **NOTE.** Apply a thick bead in the valley of the block, both front and rear. This should be a minimum of 3/8" ID tall. **See figure.**

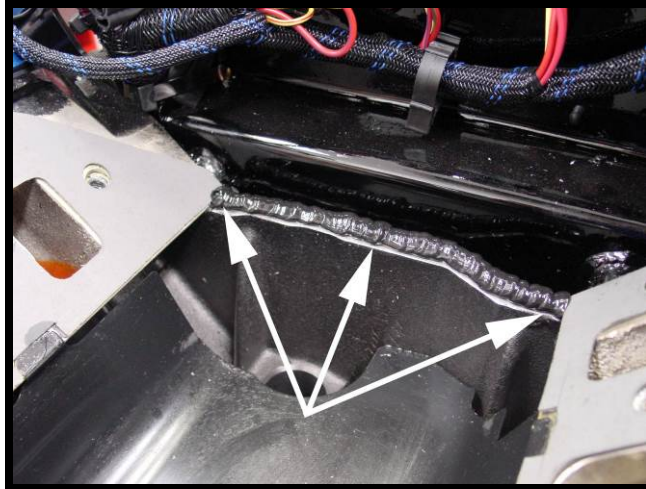

- ❑ Install intake manifold using the (11) – 3/8" x 1.5" socket head allens, (1) 3/8" x 1.5" hex head bolt and the .680" stainless washers. Utilize the hex head bolt in the forward most bolt on the inside of intake, **see figure** (above #2 cylinder). **Note: Install all bolts hand tight and align intake runners as much as possible. Also test fit the distributor to make sure everything lines up. If it does, proceed, if it does not, you may have to file one of the openings.**

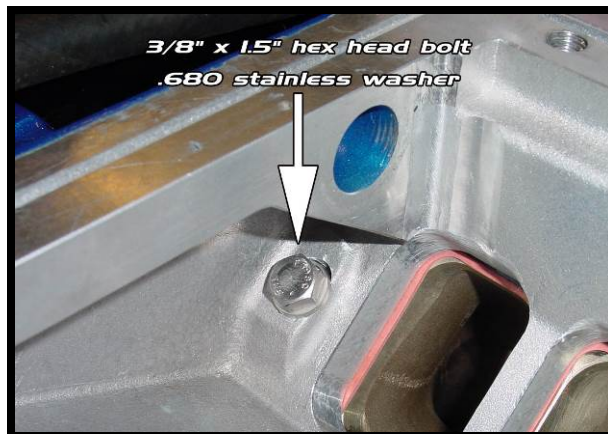

- ❑ Install supplied oring to manifold-to-intercooler flange surface. Apply a light amount of marine style grease to oring surface; follow by pushing the oring into its receiver groove. Bunch it up as much as possible, which will help as the oring shrinks. Once you have the oring all the way around, cut both ends so there straight and push into groove. These ends should bunch up together. You can also vulcanize them by roughing the edges and using "crazy glue" to mend the two together. Once completed, apply some more marine type grease to oring surface.
- ❑ Apply light amount of marine type grease to orings on intercooler core front mounting surface (**see figure**), carefully install intercooler core into intake manifold. Take the two – 12AN stainless water fittings, apply light amount of marine type grease around green oring,

Whipple Charger Installations Instructions for Mercury 454/502 Magnum Engines

apply pipe sealant to threads and install into intercooler core evenly. Do not tighten one while one is loose, this could cause the core to go in unevenly.

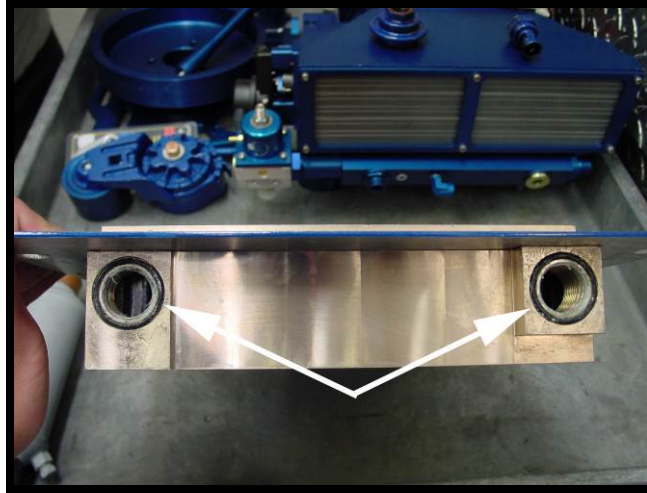

- Install the supplied injector pigtail to injectors. This should come out to the port side of the engine. Push until you hear each connector click in place. Move connectors around so they're not pushing the injectors off center.
- Reinstall the distributor and distributor clamp.
- Install plug wires. Firing order is 1-8-4-3-6-5-7-2.

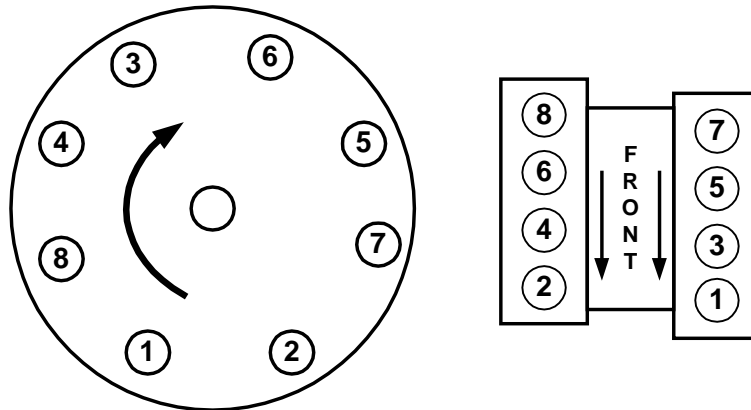

- Install supplied oring to supercharger adapter plate. Apply a light amount of marine style grease to oring surface; follow by pushing the oring into its receiver groove. Bunch it up as much as possible, which will help as the oring shrinks. Once you have the oring all the way around, cut both ends so there straight and push into groove. These ends should bunch up together. You can also vulcanize them by roughing the edges and using "crazy glue" to mend the two together. Once completed, apply some more marine type grease to oring surface.
- Install supercharger assembly by lying on intake manifold. Install the 7/16" socket head allen

Whipple Charger Installations Instructions for Mercury 454/502 Magnum Engines

bolts and torque to 35 ft. lbs.

6. Locate the two barbed fittings on the backside of the intake manifold. Install the supplied 1/8" rubber line to the 1/8" fitting (starboard side of intake) to the adjustable regulator barbed fitting. Route the 1/4" vacuum line to the new 2-bar map sensor that will be located on billet front tensioner plate system.
7. Install new thermostat housing with the supplied 3/8" x 3/4" socket head allen bolts and new thermostat gasket. If installing the water restrictor, install flat side into intake manifold thermostat register. Install supplied 3/8" x 3/4" socket head allen in extra 2 blank holes, use pipe sealant on threads. NOTE: Do not install a thermostat, this system is made to run with NO THERMOSTAT.
8. Make sure the mounting surface of the new crank pulley on the front of the balancer is perfectly flat. If necessary, remove the imperfections or paint with a good flat file.
 - (SERP) Install the Whipple dual serpentine crank pulley on the factory balancer utilizing the 3/8" x 2.5" hex head bolts. Each bolt should get 1 AN flat washer (goes against crank pulley) and lock washer. Apply a small amount of Red Loctite™ on threads to new longer crank pulley bolts and torque to 35 foot-pounds.
 - (VBELT) Install the Whipple triple V/serpentine crank pulley on to the factory balancer utilizing the 3/8" x 3.5" hex head bolts. Each bolt should get 1 AN flat washer (goes against crank pulley) and lock washer. Apply a small amount of Red Loctite™ on threads to new longer crank pulley bolts and torque to 35 foot-pounds.
9. Intercooler plumbing:
 - Before installing the front plate system, it is best to install the 90-degree intercooler fittings now. Pre route intercooler hose, both from the pickup to the intercooler as well as from the intercooler to the dump fitting. It does not matter what side you feed or drain the intercooler. One hose can come up towards the bottom front of the clear coolant reservoir and route along the factory cooling lines. This will keep the installation clean.
 - Drill transom for -12AN stainless water dump. Use marine type silicone to seal fitting to transom.
 - Apply some marine type grease to inside edge of 3/4" ID push on hose. Push 3/4" hose onto 90-degree push-lock fittings.
 - Install 90-degree fitting to starboard side of intercooler. Tighten fitting. Route hose to thru-hull dump fitting or intercooler transom pickup.
 - Repeat for the next 3/4" ID hose; push on to 90-degree fitting, install onto port side cooler fitting. Route to intercooler transom pickup or thru-hull dump fitting.
 - Push the 3/4" hose on to the -12AN brass push lock fitting. Install brass push lock fitting onto water dump fitting.

Whipple Charger Installations Instructions for Mercury 454/502 Magnum Engines

- ☐ Make sure the intercooler lines do not interfere with anything, can rub anything sharp or be in contact with something hot such as the headers.

It is recommended to use a few tie straps for this step: they're cheap!!!

- ☐ Find an accessible location on the transom of the boat, preferably 16"-28" past the centerline of the boat. Mark a spot for the -12AN stainless IC pickup. The pickup is made long so it can be cut to fit. **See following diagram:**

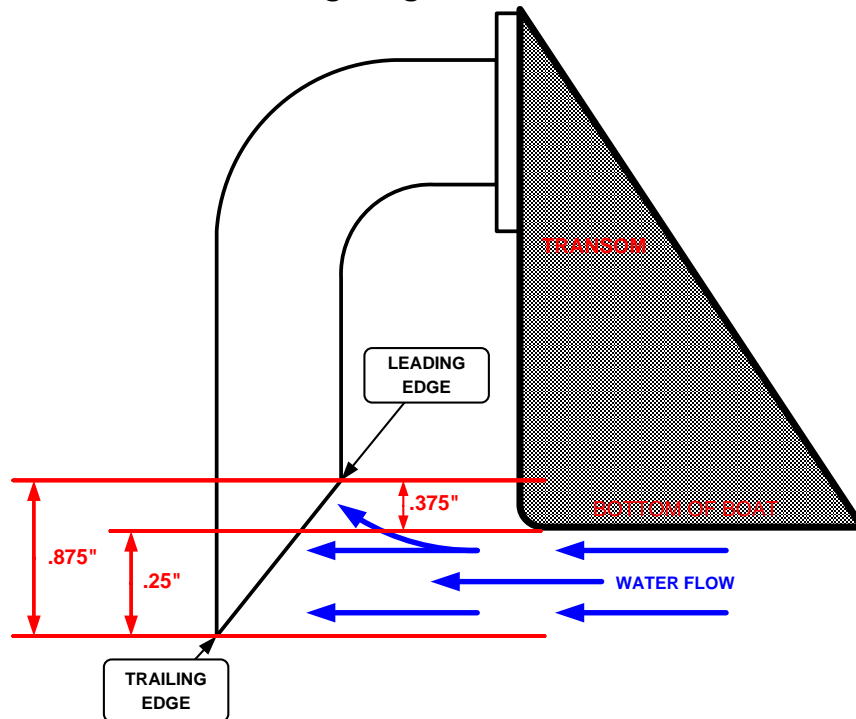

10. Stainless water cross-over system:

- ☐ (VBELT) Install stainless water cross over utilizing the new gaskets and 4 3/8" x 3/4" socket head allen bolts. Inlet feed should be facing down on port side.
- ☐ (SERP) Install stainless water cross over with new gaskets, this requires you to install the new billet belt system at the same time. Use the 4 aluminum spacers that fit against the water cross over and through the new plate, use the 2 - 3/8" x 3.5" socket head allens and washers to secure starboard side of plate. On the port side, use the supplied oil cooler/power steering support bracket with 2 3/8" x 3.75" socket head allen bolts.

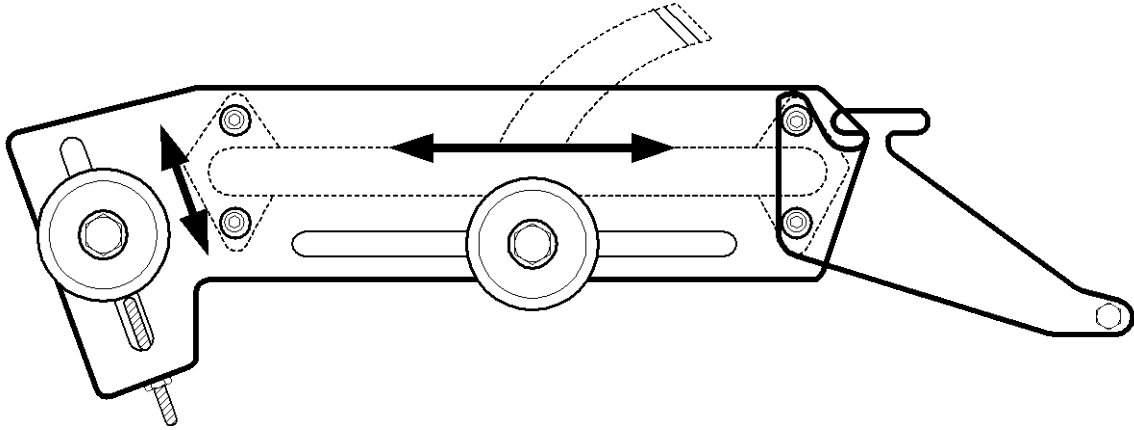

11. Water routing:

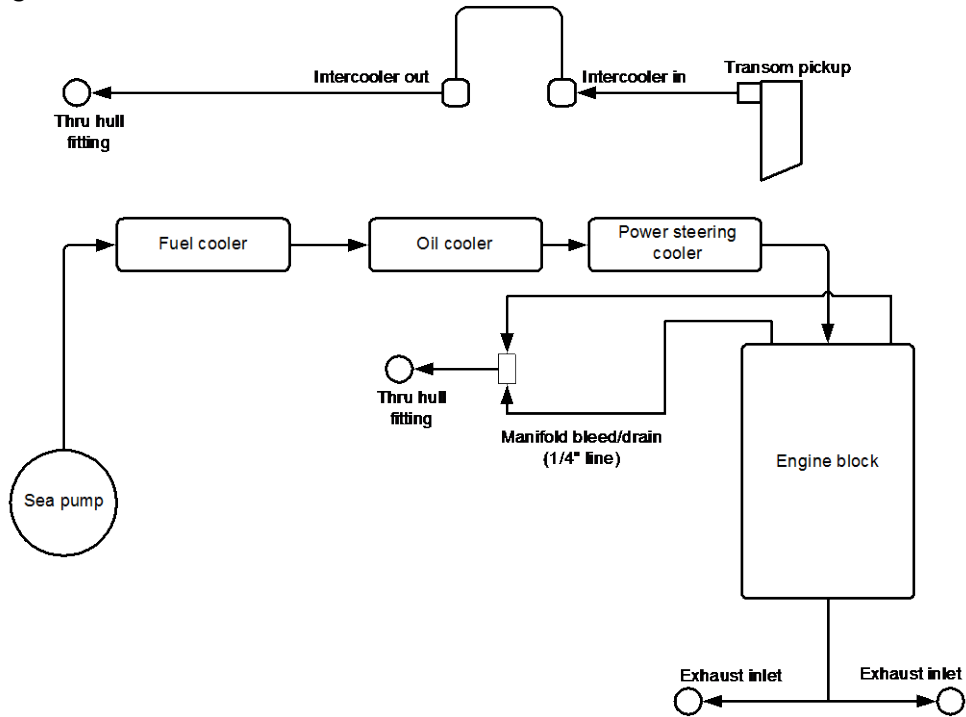

Whipple Charger Installations Instructions for Mercury 454/502 Magnum Engines

- (SERP) Use the supplied "U Bend" hose to connect too water crossover inlet from the factory oil cooler. Cut supplied hose and fit so there are no kinks of any kind (see **following diagram** for reference). Secure hose with factory clamp off.

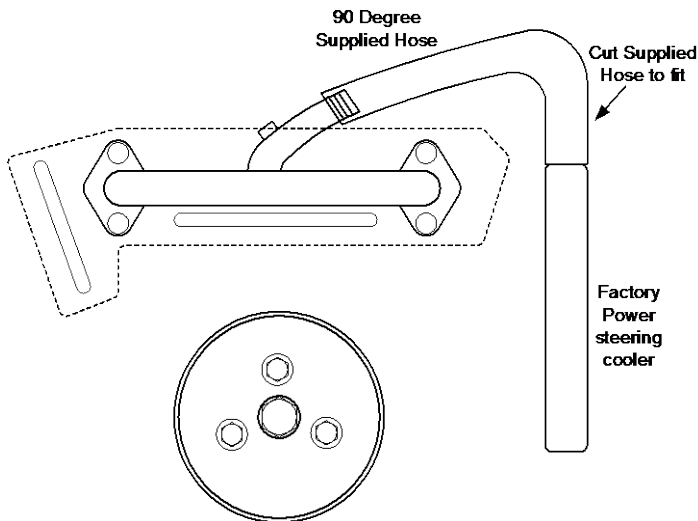

- (VBELT) Utilize factory hose from factory coolers, route to port side inlet of stainless cross over. Cut hose to fit. Some hoses may need to be replaced if worn or cracked.
- Install factory hose and clamps to new thermostat housing and bottom water feed on stainless exhaust.
- Make up $\frac{1}{4}$ " ID hose from the fittings coming out of the back of the intake manifold to the water dump fitting with the tee installed. Secure with hose clamps.

12. Front plate/support installation:

- Take the round support stands and tighten on setscrews. Tighten using the hex area on stand.
- Take front plate assembly and slide collar and front plate over the drive just slightly. **NOTE: the (5) $\frac{1}{4}$ " socket head allen bolts in drive collar are not tight, you must apply blue Loctite to threads. DO NOT TIGHTEN $\frac{1}{4}$ " SOCKET HEAD ALLEN BOLTS YET.**
- Install the (2) $\frac{3}{8}$ " X 1.5" button head allen bolts with .870" washerhand tight through front plate.
- Install the SC pulley to pulley hub on drive snout (for test fit only), verify the alignment between the back face of the SC pulley and the front plate. Move forward or backwards as necessary.
- With the (2) $\frac{3}{8}$ " button head allen bolts hand tight and plate aligned, tighten the (1) $\frac{1}{4}$ " socket head allen bolt that secures the drive collar to the drive snout. Torque to 110 in/lbs.

Whipple Charger Installations Instructions for Mercury 454/502 Magnum Engines

- Torque the (2) 3/8" x 1/5" button head allen bolts that secure the front plate to the support stands to 25 ft/lbs.
- Torque the (4) 1/4" socket head allen bolts that secure the front plate to the drive collar to 110 in/lbs. Make sure these have blue Loctite on threads.
- Install SC pulley (5mm allen) with the supplied (4) 6mm 14mm socket head allen bolts. Torque to 125 inch lbs. (VBELT systems use the .330" pulley spacer and 6mm x 22mm socket head allen bolts).

13. Fuel System installation (supplied hoses/fittings are good for up to 750hp, anymore will require larger fuel filter/head/fittings and hoses): ☠

- Remove factory fuel filter assembly.
- Mount supplied fuel filter/water separator into factory location. Make sure to leave room to get the filter off later for service.
- Mount the pump to a secure location such as a stringer. **!! CAUTION !!** It's ideal to mount lower than the fuel tank outlet fitting so the pump will always have a prime. If you mount higher than your tank (not recommended), then you should utilize a -10 AN check valve on the inlet side to ensure that the pump has a prime (contact Aeromotive).
- Mount the new fuel cooler after the sea-pump outlet. Use the supplied #20 hose clamps to secure. You can mount this in 2 places. First is next to the starter and the other is in place of the factory cool fuel assembly. Either will work.
- Install the supplied 1/2" NPT to 1/2" 90deg barb fitting into the inlet #1 of the new fuel filter head. Apply light amount of pipe sealant to threads.
- Install the supplied 1/2" NPT to 1/2" barb fitting into the outlet #1 of the new fuel filter head. Apply light amount of pipe sealant to threads.
- Install the supplied 1/2" NPT to 3/8" barb fitting into the inlet #2 of the new fuel filter head. Apply light amount of pipe sealant to threads.
- Install the supplied 1/2" NPT plug into the outlet #2. Apply light amount of pipe sealant to threads.
- Inspect factory fuel lines from tank(s), check for any restrictions such as check valves and inline filters. All restrictions must be removed to allow proper fuel flow.
- If factory fuel line is smaller than 1/2" ID, replace the corresponding fittings and hose with USGC approved hose. Secure with #10 hose clamps.

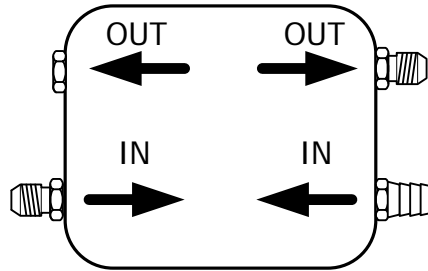

- Install the supplied -10 flow to -8 flare fittings with the supplied -10 Viton oring into the new high flow fuel pump "INLET".
- Install the supplied -10 flow to -6 flare fittings with the supplied -10 Viton oring into the new high flow fuel pump "OUTLET".
- Remote mount adjustable fuel psi regulator. This can be located off the back of the intake manifold, off the transom or anywhere near the SC. Ideally, this should be mounted within 18" of the fuel rail.
- Install -10 allen plug into fuel PSI regulator in unused regulator inlet.
- Install the supplied steel -6AN oring fitting on the bottom side of the fuel pressure regulator.
- Install the supplied 1/8" barbed fitting into the fuel pressure regulator. (Parts are in regulator box).
- Install supplied 1/8" pipe plug into fuel pressure regulator. Apply light amount of thread sealant to threads.
- Install pipe sealant to fuel cooler 3/8" NPT to -6AN steel fittings. Install fittings to cooler.
- Install factory fuel line from tank to barbed fitting, secure with factory clamp (utilize factory fuel line and clamp that routed to the first stock fuel pump).
- You must now manufacture fuel lines. Use only high quality, high-pressure fuel lines!!**

Whipple Charger Installations Instructions for Mercury 454/502 Magnum Engines

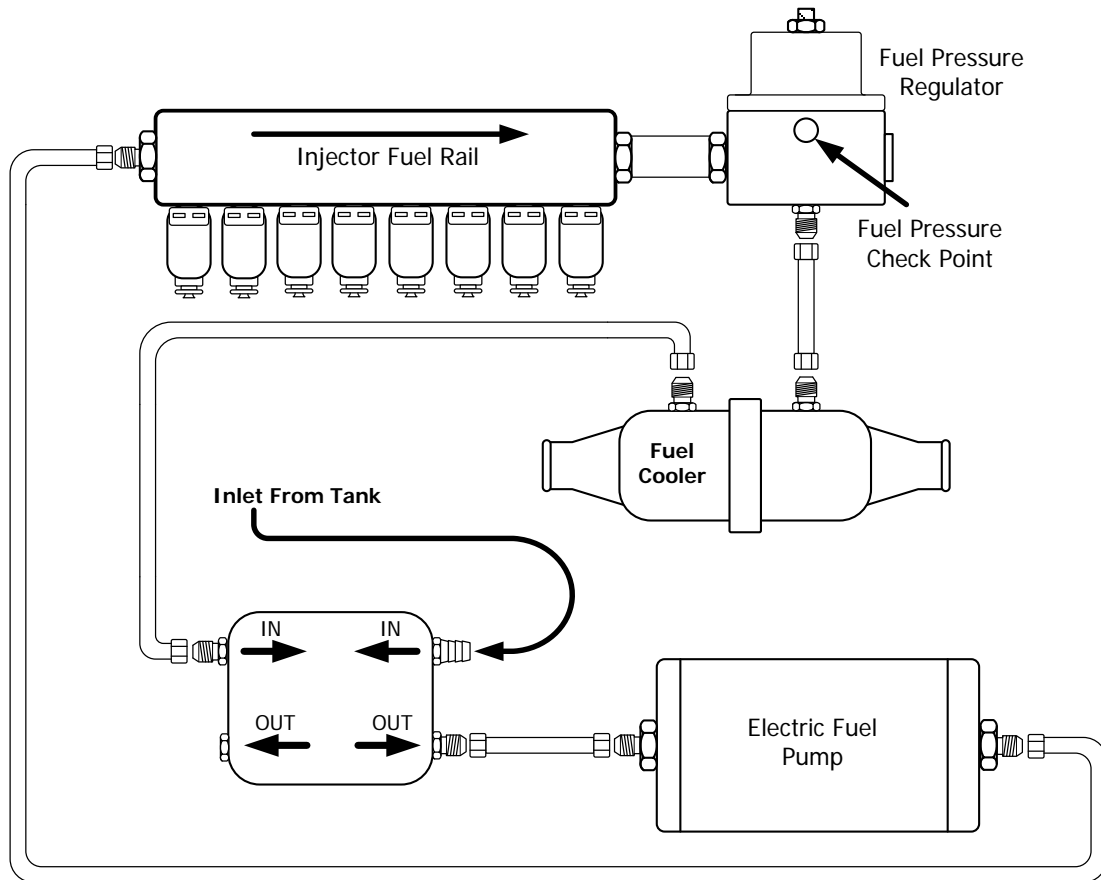

- Manufacture a 1/2" ID USGC approved hose from the fuel filter outlet #1 to the fuel pump inlet. Secure hose to barb fitting with #10 hose clamp.
- Manufacture a 3/8" ID USGC approved hose from the fuel rail to the fuel PSI regulator (either side of regulator).
- Manufacture a 3/8" ID USGC approved hose from the fuel pump outlet to the Whipple fuel rail (either side).
- Manufacture a 3/8" ID USGC approved hose from the fuel PSI regulator discharge fitting to the fuel cooler.
- Manufacture a 3/8" ID USGC approved hose from the fuel cooler to the fuel filter inlet #2.

Whipple Charger Installations Instructions for Mercury 454/502 Magnum Engines

14. Electric fuel pump wiring instructions:

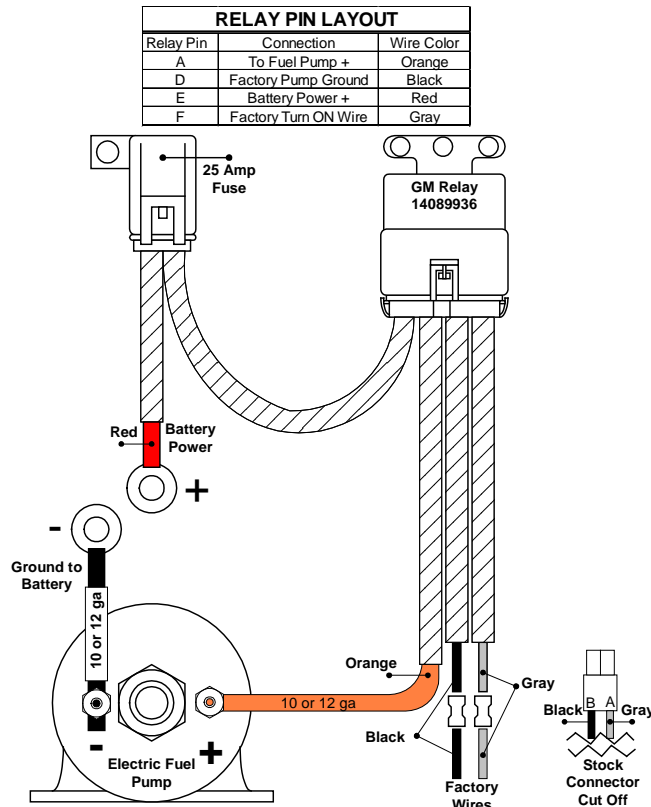

- Locate the factory electric fuel pump connector. This connector has a gray wire (Pin A), which is the turn on wire and a black wire (Pin B), which is a ground.
- Cut the factory connector off, strip wires and connect to supplied relay harness (see **following diagram** for reference). Connect the new harness gray wire to factory gray wire. Connect new harness black wire to factory black wire (preferable solder and heat shrink). Mount relay and fuse on back of engine or transom.
- Route red wire from 25-Amp fuse to battery power.
- Route orange wire to electric fuel pump positive +. **(10 or 12 ga only!!!)**.
- NEVER ROUTE RED POWER WIRE TO TRIM PUMPS!**

It is recommended to use a few tie straps for this step: they're cheap!!!

Whipple Charger Installations Instructions for Mercury 454/502 Magnum Engines

15. Take factory PCV valve and take straight plastic top off. 93-97 engines will receive PCV valve to install into port side valve cover. Route 3/8" hose to barbed fitting coming from throttle body.
 - Install new 3/8" ID hose with new 90-degree plastic fitting onto PCV valve.
 - Insert PCV valve in port side valve cover. Install 90deg 6AN push lock fitting into end of 3/8" ID hose. Install 90deg fitting to the 6AN fitting pre-installed on port side of Whipple throttle body.
16. Install #1519 valve cover breather into factory rubber grommet in valve cover.
17. Install factory 6 rib grooved idler on Whipple plate on diagonal position with adjusting setscrew up and down. Use the tee nut to slide back and forth, the idler spacer to space idler out correctly and the idler washer that centers the hex bolt on front side of idler bearing.
18. (VBELT) Install the 2 new supplied v-belts to accessories. You will reutilize one factory belt.
19. (SERP) Install new 6 rib belt as shown in this diagram: Once installed tighten by using the all thread stud on the bottom of the idler **as shown in following diagram**.

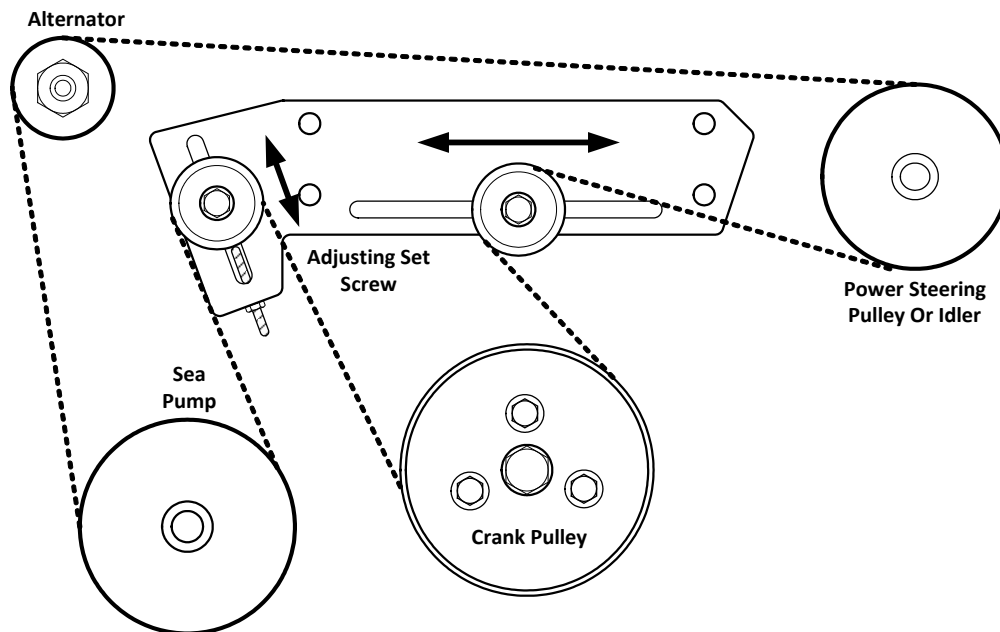

20. (99-2002 MEFI 3) Relocate factory "Merthacode" assembly on backside of head with the supplied steel bracket (center of plate has 2 cutouts). Use supplied 3/8" x 3/4" socket head stainless bolts and 3/8" S.S. AN washers to secure.
21. Install remote mount IAC adapter with breather filter. This shares the Merthacode pattern, therefore it can be sandwiched over the Merthacode, replace the Merthacode or be remote mounted. Install the factory IAC motor in the IAC adapter and make 1/2" ID hose line with the supplied push lock fittings (90deg and 45deg).

Whipple Charger Installations Instructions for Mercury 454/502 Magnum Engines

22. Locate the ¼" barbed fitting on port side of intake manifold. Install supplied 1/4" vacuum line to this and route to map sensor that is located on backside of front plate. Secure with zip ties.
23. Locate the barbed fitting on starboard side of intake manifold (1/8"). Install supplied 1/8" vacuum hose and route to fuel pressure regulator barbed port. Secure with zip ties.
24. **⚠ WARNING!!** Fill the new s/c compressor with oil per supplied instructions.
 - Make sure the SC is sitting square/flat.
 - Remove -4AN allen plug and fill SC with **WHIPPLE SC OIL ONLY!!**
 - Fill to the middle of the sight glass. NOTE: The W200AX compressor takes a maximum of 6.8 fl/oz (200mL).
 - Reinstall -4AN allen plug.
 - NOTE: After running the SC, the oil level will lower due to oil filling the bearings. The proper level should be between the bottom of the sight glass and the middle.
 - Change SC oil every 100 hours (every season) and only use **WHIPPLE SC OIL!!**

!! CAUTION !!

Severe damage to the compressor will occur if you overfill the supercharger front gear case.

WHIPPLE SC OIL LEVEL

*Fill to center of oil sight glass. 6.8 fl/oz. or 200cc.
DO NOT OVERFILL, WILL VOID WARRANTY!!*

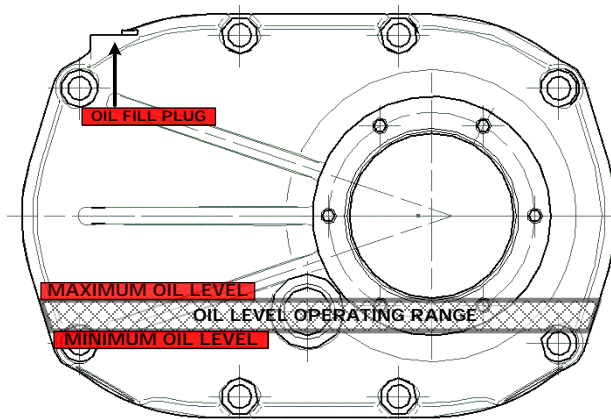

25. Wiring Instructions (MEFI 1 systems must upgrade and reconfigure harness for MEFI 4, see wiring matrix later in instruction manual):
 - Locate the 8 fuel injector connectors, Throttle Position Sensor connector and Idle Air Control connector. Cut the electric tape on the split loom and pull the wires back towards the rear of the motor for the new injector location. They do not need to be lengthened, just pulled out of the split loom. It does not matter which order they go in. Some may need to separate the supercharger from the intercooler housing by removing the 3 3/8" hex bolts to get to the

Whipple Charger Installations Instructions for Mercury 454/502 Magnum Engines

injector connectors. If you separate them, clean the silicone from the 2 surfaces and reseal with black RTV silicone when putting back together. Torque to 35 ft. lbs.

- Once you have pulled the injector connectors back far enough, plug them into the 8 new injectors.
- Plug in factory TPS connector to new TPS sensor.
- Plug in factory IAC connector to IAC motor.
- Install factory connector to Inlet Air Temp sensor.
- Connect brown engine coolant temp sensor wire for gauge.
- Connect factory engine coolant temp sensor to sensor in manifold.
- Find the factory map sensor connector and plug in the wiring extension. Now install the new orange map sensor connector to the map sensor located on the front plate.

26. Install SC belt by releasing the tension from the tensioner and loosening the mounting bolt on the sliding idler.

- Once belt is on all pulleys, push the sliding idler towards starboard side until you can release the tensioner so that it's pointing at a 5 O'clock position. Notice the stops on the tensioner, it must have play both forward and backwards to work properly. **See following diagram.**

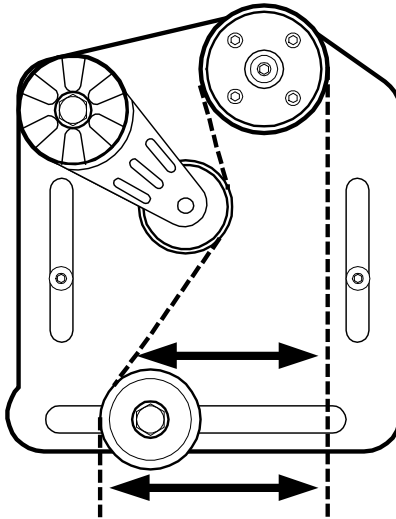

Whipple Charger Installations Instructions for Mercury 454/502 Magnum Engines

27. Install the supplied $\frac{1}{4}$ "-20 x 1 $\frac{1}{2}$ " stud into the throttle arms upper $\frac{1}{4}$ " hole.

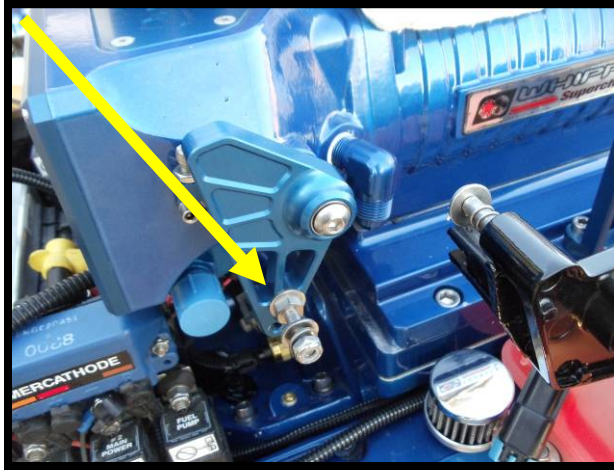

28. Install the supplied $\frac{1}{4}$ "-20 x 1 $\frac{1}{2}$ " stud into the throttle anchor position.

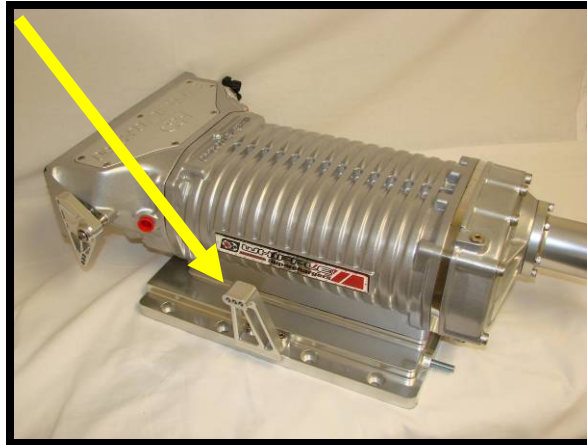

29. Route the linkage to the front of the motor, starboard side. Test fit the factory linkage length to see what hole position on the anchor, as there are 3 hole positions for multiple length configurations. Once you've figured a position, install anchor to $\frac{1}{4}$ " stud by using a supplied $\frac{1}{4}$ " AN washer on both sides of the linkage anchor and secure with supplied $\frac{1}{4}$ " nyloc nut.



Whipple Charger Installations Instructions for Mercury 454/502 Magnum Engines

30. To properly install the linkage end on the stud and throttle arm, its important to put a slight amount of "pre-load" on the linkage to ensure proper and consistent closing. Adjust the end enough that when you push over the stud, its not set in a neutral position, but pushing slightly on the linkage in a closed position. Install the supplied 1/4" AN SS washer on both sides of the linkage arm. Secure with the supplied 1/4" nyloc nut. Start at the bottom hole, then move the throttle to 100% open, verify that the linkage is at max opening. If not, move the stud up one hole and repeat.

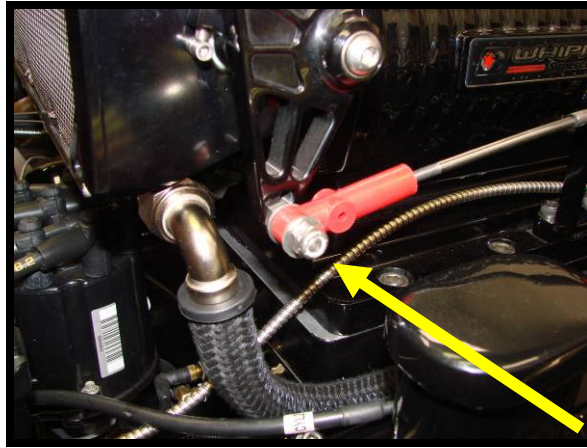

31. Relocate the shifter bracket to the transom.



BEFORE STARTING THE ENGINE

MAKE SURE THE THROTTLE CABLE OPERATION IS CORRECT. WITH THE ENGINE OFF, MOVE THE THROTTLE A FEW TIMES TO FULL OPEN AND CLOSED POSITIONS. THERE SHOULD BE NO BINDING OR STICKING AND SHOULD OPERATE FREELY.

PRIME FUEL PUMP WITH FUEL!! DO NOT RUN THIS PUMP DRY UNDER ANY CIRCUMSTANCES!! THERE ARE NO WARRANTIES FOR PUMPS RAN DRY.

32. Adjust fuel pressure TEMPORARILY: **DO NOT RUN PUMP DRY!!!!**

- Install quality mechanical fuel pressure gauge (do not use electric gauges to tune) to 1/8" pipe fitting on adjustable regulator.
- Prime fuel system so that filter is full of 91-octane gas.
- Turn key "on" and quickly bleed air from fuel line anywhere on pressure side.
- Turn key to on position, look at pressure and adjust close to **40lbs**. **This is temporary to get the engine running.**

33. **⚠ WARNING!!** On the opposite side of the linkage, locate the TPS sensor. With the key in the on position, probe the blue wire to measure the 0-5v sensor and make sure it's within range of 0.45v - 0.50v. Make sure the throttle body is closed. If it's not in the proper range, following the next instruction to adjust this setting.

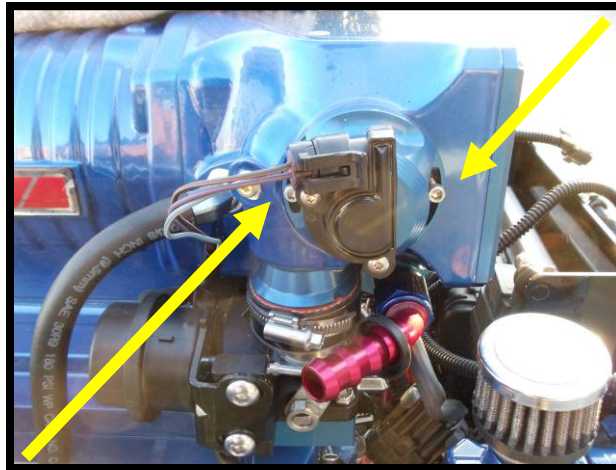

34. Notice that the TPS sensor is bolted to a billet adapter. This billet adapter is made to rotate in standard and clockwise rotation. Slightly loosen the (2) allen bolts that hold this piece to the throttle body. With your voltmeter, adjust until you find the same voltage as the stock throttle body. Once found, tighten billet adapter. Make sure that during tightening, it did not move.

Whipple Charger Installations Instructions for Mercury 454/502 Magnum Engines

35. **⚠ WARNING!!** With key power on, open (100%) and close throttle 4-5 times, with the throttle closed, verify that TPS voltage is the same as what you set earlier. If it's higher, you need to preload the linkage more so it is consistent in closing at the same spot. To preload the linkage, adjust the factory throttle linkage so that it barely fits over the (2) throttle linkage studs. It should almost be too long in length to fit, this will always force the linkage closed.
36. Install the 91-octane decal on the dash, in a visible location.



STARTING THE ENGINE

37. You must set base ignition timing at 8 degrees.

- Locate DTC connector on port side rear black panel of engine. Should be on top near Merthacode. It has a plastic cover over it for water protection, remove this to do the timing setting.



- Connect timing light to number 1 ignition wire.
- Start the engine and let idle (may have to give some slight throttle).
- Connect the appropriate tool (timing tool #91-805747A1), Rinda scan tool or jump pins A & B on the DLC with a bare wire/paper clip to hold the engine in base timing mode.

- Manually adjust throttle so engine RPM is steady 1500rpm.
- If you have a Rinda scan tool, set the engine in "service mode" which will set it in base timing mode.
- Shine the timing light at the timing mark indicator located on the timing chain cover.
- Adjust the distributor until you get the desired 8 degrees BTDC. Clockwise to retard timing, counter-clockwise to advance timing.
- Torque distributor bolt down bolt to 30 foot-pounds.
- Verify that the motor is 8 degrees BTDC after the distributor was tighten, adjust if needed.
- Set scan tool to "normal mode" or remove the base timing tool.

YOU MUST USE A HIGH QUALITY, HIGH ACCURACY MECHANICAL FUEL PRESSURE GAUGE ONLY!!! NEVER ADJUST WITH AN ELECTRIC GAUGE!!

PRIME FUEL PUMP WITH FUEL!! DO NOT RUN THIS PUMP DRY UNDER ANY CIRCUMSTANCES!! THERE ARE NO WARRANTIES FOR PUMPS RAN DRY.

38. Adjust fuel pressure: **DO NOT RUN PUMP DRY!!!!**

- Install quality mechanical fuel pressure gauge (do not use electric gauges to tune) to 1/8" pipe fitting on adjustable regulator.
- Start the engine, and disconnect the 1/8" vacuum reference line from the fuel psi regulator.
- Adjust fuel pressure to **40psi**.
- Reconnect the 1/8" vacuum reference line from the fuel psi regulator. Secure both ends with zip ties.

FUEL IS UNDER PRESSURE!! Be very careful while removing the fuel rail bolts as fuel may be released under pressure. Prevent fuel spray by covering the injectors with a shop towel while the bolts are being loosened.

- With motor running in vacuum, pressure should drop once line is connected and will rise above 40 under boost. **Under full boost, the fuel pressure must hold a steady 45lbs. of pressure (+/- 2lbs).** If not, there is a restriction in the line.

IDLE SPEED SETTING

39. Some motors may need an idle adjustment. First, you must understand the ECU has a desired idle speed that the motor is always going to try to achieve. The rpm idle speed should be 750 rpm once motor is up in the 80+ range of engine coolant temperature.

- On the starboard side of throttle body, there's the linkage arm that is pushed over a splined shaft. Remove the linkage arm from the throttle body so you can have better access to the throttle stops.
- As shown in the following **figure**, you must adjust the setscrew to raise or lower the idle speed. Note that this is where the throttle stops in the relaxed or returned position.

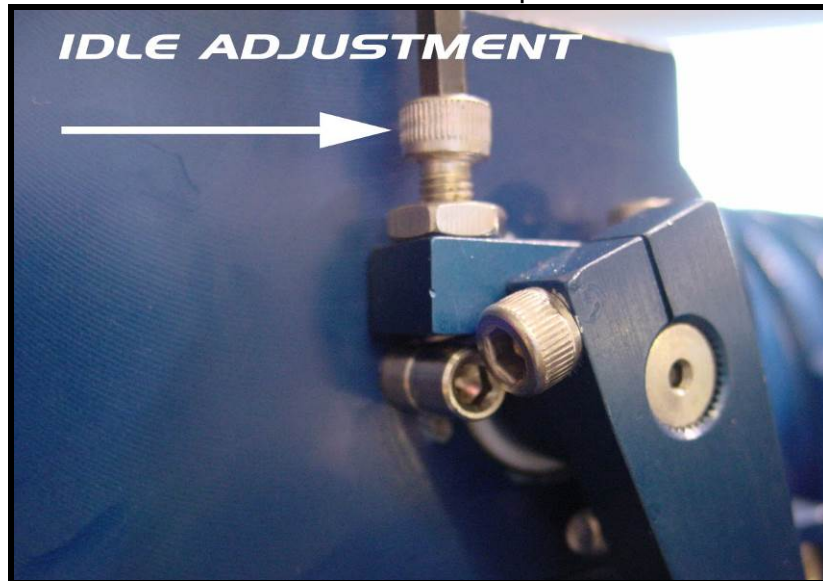

Engines that idle to high:

- This means either there's a vacuum leak, too much timing or there is too much air going by the throttle blades. To lower airflow at idle, take the set screw/throttle stop and lower it. This allows the throttle blade to close more when returned. Make small adjustments such as 1/8th turns. **NOTE: Don't forget to tighten locking nut after adjustment.**

Engines that idle to low:

- This means either there's not enough air being fed to engine or not enough timing. To increase airflow at idle, take the set screw/throttle stop and raise it so when the throttle is in its relaxed position, it will be slightly open more. Make small adjustments such as 1/8th turns. **NOTE: Don't forget to tighten locking nut after adjustment.**
- To raise the voltage, you must make the setscrew (acts as throttle stop when in returned position) open the throttle blade more. This will raise the RPM (if it's loping between 600-1000, open the blade). If the RPM is to high, you must close the blade (lower the voltage). If you do have a scanner, watch the IAC count. You want it to be between 20-50. You must

shut the motor off for 5 seconds to reset the IAC motor. If you do not have a scanner, you can adjust this setscrew until you see the motor idles around 750 on the tachometer, the motor should not hunt more than 100 RPM.

- Rev engine up past 2500 rpm and bring back at a rapid rate. The motor should not die, it should come back to the desired idle speed within 1-5 seconds. If it dies, then it needs more air so follow instructions for engines that idle too low.

Motors that idle high only after revving the engine or there are no more adjustments to be made:

- This means the TPS voltage is slightly off and that it does not return to its "Closed Loop Idle System." To fix this, you must loosen the TPS sensor (located on port side of throttle body) and push the top out towards the back of the boat. This will lower the TPS voltage. Tighten allens and try starting it again. You may want to use the scanner or a volt-meter (0-5volt sensor output) to watch the voltage come down. Ideal voltage should be in the range of 0.40 – 0.50 volts.

CRITICAL!!!

LAKE TEST POST-INSTALLATION CHECKLIST

After installing the Whipple supercharger kit it is imperative that the following checklist be performed. Failure to perform these simple tests may result in severe engine damage.

1. Make sure 91 octane or higher is in the vessel. If unsure, then drain the tank completely empty and fill with 91 or higher.
2. With the thermostat removed, under full throttle operation, near full speed, **block pressure should be a minimum of 25lbs. and maximum of 40lbs.** If block pressure is not present, severe engine damage may occur. The motor should have 0-2lbs. at idle and should progressively get higher as speeds increase. A low water nose style pickup or external pickup may need to be installed. The Mercury side hole pickups will not generate enough water flow for proper operation. If you have an XZ drive with dual water pickups, it **WILL** be necessary to plug side draft holes to increase pressure.
3. Fuel pressure is the most critical parameter and must be checked during wide-open throttle operation. Install a quality fuel pressure gauge to the extra port at the auxiliary fuel rail added by Whipple (1/8" pipe). Attach the fuel pressure gauge with a long enough hose so that it may be visible during operation. **Under WOT, full boost, max rpm, the fuel pressure should be 45 lbs (+/- 2lbs).** This procedure takes two people – one to drive and the other to observe the gauge. Perform the test in a safe area. If it does not maintain fuel pressure, you must find the restriction, as this results in a lean air to fuel condition.

MAINTENANCE AND SERVICE

It is recommended that the following items be checked at normal service intervals.

1. Check supercharger oil every 10-15 hours of operation.
2. Change supercharger oil every 50 hours or every season, whichever comes first.
3. Check the supercharger/accessory drive belt. Adjust or replace as required.
4. Inspect and clean fuel filter every 25 hours.
5. Clean idle air motor conical filter every 15 hours.
6. Inspect spark plugs every 25 hours.
7. Replace spark plugs every 50 hours or once a season, whichever comes first.
8. Replace distributor cap and rotor every 50 hours or once a season, whichever comes first.
9. Replace plug wires every 100 hours or every 2 seasons, whichever comes first.
10. Follow factory service intervals for all other components.

DO NOT!!!

1. Never run octane less than 91.
2. Do not use octane booster, these are very hard on the spark plugs and only increase a few points. Example: 87 octane with octane booster, may raise a few "points" to 87.5, which is not acceptable.
3. Never operate engine if overheating.
4. Never operate engine in boost if water temp exceeds 140.
5. Do not operate engine in boost if water pressure has fallen below standard levels.
6. Do not operate engine in boost if fuel pressure falls below standard levels.
7. Do not tee the vacuum/boost line feeding the Map sensor, use the other pipe holes located in the manifold.
8. Do not design your own fuel system, the system is designed for use and installation as we specify.
9. Do not run more timing than 8 degrees base.
10. Only run spark plugs that are specified by Mercury Hi-Performance.

Whipple Charger Installations Instructions for Mercury 454/502 Magnum Engines

MEFI 1 & 2					MEFI 3				
Pin Location	Signal/Sensor	Color Wire	>>>>	Pin Location	Signal/Sensor	Color Wire	Extra Information		
J1-1	Knock sensor signal	Black	>>>	J1-30	Knock Sensor Signal	Dark Blue	Knock sensor		
J1-2	Coolant sensor signal	Yellow	>>>	J2-11	Coolant sensor signal	Yellow	ECT sensor connector pin B		
J1-3	Not used								
J1-4	I/O Fluid level	Dark Green					Engine 2		
J1-5	Master/Slave	Yellow	>>>	J2-21	Master/Slave	Yellow	Oil pressure switch		
J1-6	Oil pressure	Brown	>>>	J2-7	Oil Pressure	Blue	Diagnostic B		
J1-7	Diagnostic Test	White/Black	>>>	J2-22	Diagnostic Test	Black/White			
J1-8	Not used								
J1-9	MAP signal	Light Green	>>>	J2-27	Map Signal	Light Green	Map sensor connector pin B		
J1-10	TPS Signal	Dark Blue	>>>	J2-26	TPS Signal	Dark Blue	TPS sensor connector pin C		
J1-11	Ignition volts	Pink/Black	>>>	J2-32	Ignition	Pink	Relay 1 splice #30 to #86		
J1-12	Not used								
J1-13	TP & IAT Ground	Black	>>>	J2-3	TP & IAT ground	Black	TPS connector pin B, IAT connector pin B		
J1-14	ECM Ground	Black/White	>>>	J1-20	ECM ground	Black	Ground		
J1-15	TPS 5V reference	Gray	>>>	J2-4	TPS 5V reference	Gray	TPS sensor connector pin A		
J1-16	Battery	Orange	>>>	J2-1	Battery	Orange	Diagnostic F (Battery)		
J1-17	Not used								
J1-18	Serial data	Orange/Black	>>>	J1-32	Serial Data	Orange	Diagnostic G (engine 2 orange)		
J1-19	Not used								
J1-20	Oil level	Light Blue	>>>	J2-23	Oil level				
J1-21	Emergency stop	Pink	>>>	J2-5	Emergency stop				
J1-22	Not used								
J1-23	Not used								
J1-24	Inlet air temp signal	Tan	>>>	J2-30	Inlet air temp signal	Tan	IAT sensor connector pin A		
J1-25	Not used								
J1-26	Not used								
J1-27	Not used								
J1-28	Not used								
J1-29	MAP & coolant ground	Black	>>>	J2-18	MAP & coolant ground	Black	ECT connector pin B, MAP connector pin A		
J1-30	ECM Ground	Black/White	>>>	J1-5	ECM ground	Black	Ground		
J1-31	Map 5V reference	Gray	>>>	J2-19	Map 5V reference	Gray	MAP connector pin B		
J1-32	Battery	Orange			Not used				

MEFI4 DIAGNOSTIC INFORMATION ONLY

**MEFI4 PIN CONFIGURATION
J1 CONNECTOR**

J1 Pin	Description	Color	Connector pin	Connector Type
J1-1	Knock signal #2 (N/A)	Light Green	(N/A)	(N/A)
J1-2	Diagnostic "test" terminal	Black/White	Pin B	10 Way/DLC
J1-3	Master/Slave (N/A)	Yellow	Pin B	2 Way
J1-4	Empty			
J1-5	Emergency Stop (N/A)	Pink	(N/A)	(N/A)
J1-6	Fuel pump relay control	Dark Green/White	Relay Pin 85	Fuel pump relay
J1-7	Empty			
J1-8	Audio warning horn	Dark Green/Black		
J1-9	Empty			
J1-10	Empty			
J1-11	Fuel injector driver B	Blue	Injectors Pin B	Injector connector
J1-12	Empty			
J1-13	Distributor Reference "low"	Red/Black	Pin A	4 Way/Distributor
J1-14	Tachometer output	Gray		Engine harness gray
J1-15	Idle air control B "low"	Green/Black	Pin A	4 Way/IAC
J1-16	Idle air control A "high"	Blue/White	Pin D	4 Way/IAC
J1-17	Knock signal #1	Blue	Knock Sensor	Single way
J1-18	Oil level			
J1-19	Empty			
J1-20	Shift interrupt (N/A)	White	Shift sensor	
J1-21	Empty			
J1-22	Empty			
J1-23	Empty			
J1-24	Gear lube switch	Tan/Black		
J1-25	Empty			
J1-26	Fuel injector driver A	Green	Injectors Pin B	Injector connector
J1-27	Malfunction indicator lamp	Brown/White	Pin E	10 Way/DLC
J1-28	ECM ground	Black	Engine block	Eyelet
J1-29	ECM ground	Black	Engine block	Eyelet
J1-30	Idle air control B "high"	Light Green/White	Pin B	4 Way/IAC
J1-31	Idle air control A "low"	Light Blue/Black	Pin C	4 Way/IAC
J1-32	Empty			

SYSTEM/IGNITION RELAY

Pin	Description	Color	Connector Pin
30	12V Power/B+	Red	
85	Ground	Black	
86	To ignition	Pink	
87	Ignition/Injector Fused	Red	J2-19

FUEL PUMP RELAY

Pin	Description	Color	Connector Pin
30	12V Power/B+	Red	Relay #86
85	Trigger from ECM	Dark Green/Black	J1-6
86	Inj./ECM 10A fuse	Black	J2-19
87	Fuel pump trigger ON	Gray Pin A	Pin A
87A	N/A	N/A	

**MEFI4 PIN CONFIGURATION
J2 CONNECTOR**

J2 Pin	Description	Color	Connector pin	Connector Type
J2-1	Battery feed	Orange		
J2-2	5 Volt reference	Gray	TPS-A/MAP-C	3 Way
J2-3	Sensor ground	Black	TPS-B/MAP-A	(2) 2 Way/(3) 3 Way
J2-4	Fuel PSI signal		ECT-A/IAT-B	
J2-5	Emergency Stop			
J2-6	Empty			
J2-7	ECT coolant sensor signal	Yellow	Pin B	3 Way/Coolant
J2-8	MAP sensor signal	Light Green	Pin B	3 Way
J2-9	Empty			
J2-10	Serial data	Orange	Pin G	10 Way/DLC
J2-11	Empty			
J2-12	Empty			
J2-13	Empty			
J2-14	Empty			
J2-15	Ignition bypass	Tan/Black	Pin B	4 Way/Distributor
J2-16	Distributor Reference "high"	Purple/White	Pin C	4 Way/Distributor
J2-17	Empty			
J2-18	Empty			
J2-19	Ignition feed	Pink	#30,#86	Ignition/Inj Relay
J2-20	Oil PSI switch	Blue/White		
J2-21	IAT sensor signal	Tan	Pin A	2 Way
J2-22	Empty			
J2-23	TPS sensor signal	Blue	Pin C	3 Way
J2-24	Empty			
J2-25	Empty			
J2-26	Empty			
J2-27	Empty			
J2-28	Empty			
J2-29	Empty			
J2-30	Empty			
J2-31	Ignition control	White	Pin D	4 Way
J2-32	Empty			

Whipple Charger Installations Instructions for Mercury 454/502 Magnum Engines

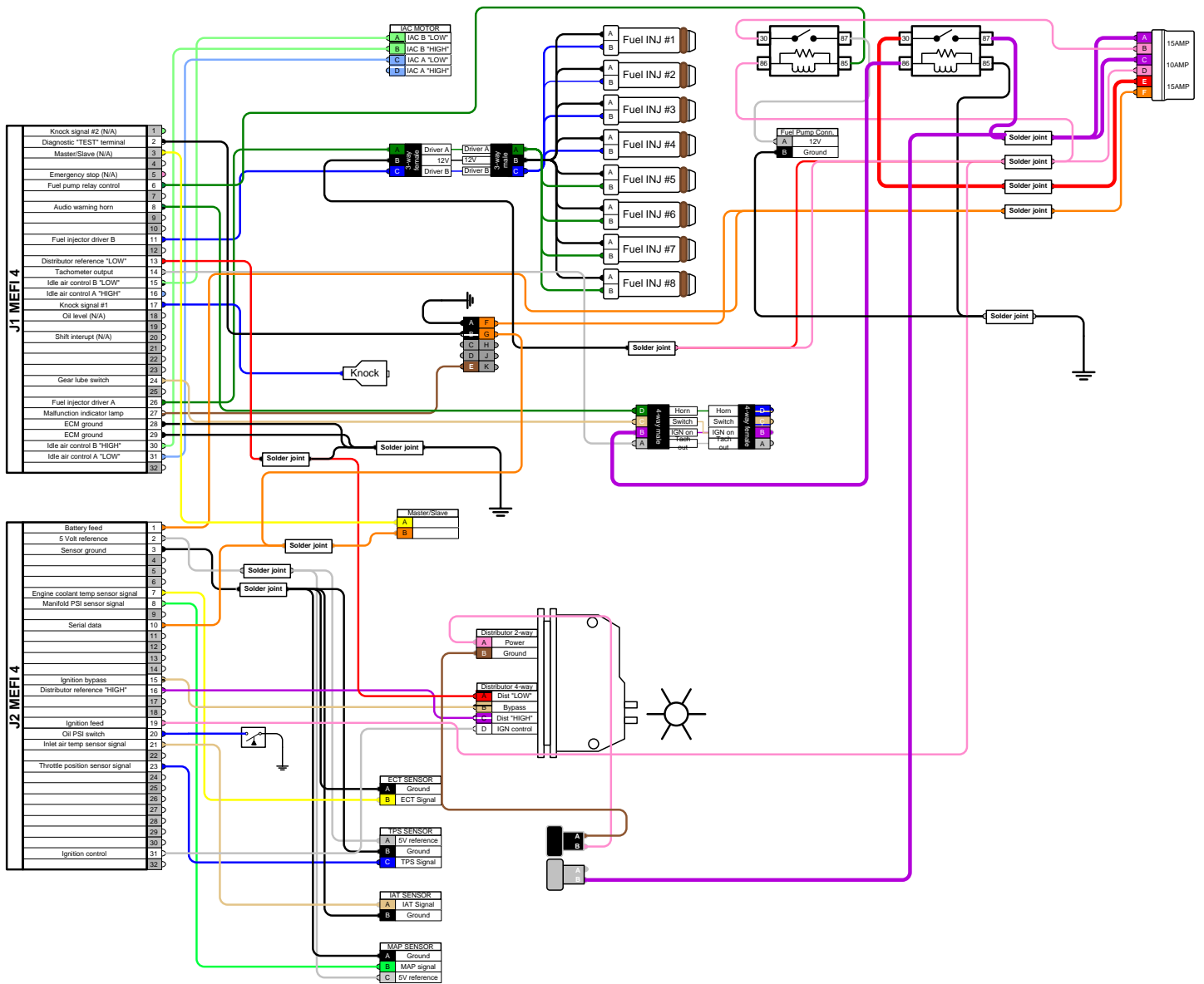

Engine Scan Tool List

The Engine Scan Tool Data List contains all engine related parameters that are available on the scan tool. Use the Engine Scan Tool Data List only after the following is determined:

- On-Board Diagnostic System Check is completed.
- No Diagnostic Trouble Codes (DTCs).
- On-board diagnostics are functioning properly.

Scan tool values from a properly running engine may be used for comparison with the engine you are diagnosing. The Engine Scan Tool Data List represents values that would be seen on a normal running engine.

Important: A scan tool that displays faulty data should not be used. The scan tool problem should be reported to the manufacturer. Use of a faulty scan tool can result in misdiagnosis and unnecessary parts replacement.

Only the parameters listed below are referenced in this service manual for use in diagnosis. If all values are within the typical range described below, refer to *Symptoms* for diagnosis.

Scan Tool Parameter	Units	Parameter Range
Calibration ID	Numeric	0-255 Identification number assigned specific calibration
Calibration Checksum	Numeric	0-65535
Engine Speed	RPM	0-6000
Desired Idle	RPM	0-1600
ECT	C, F	-40 C - 151 C, -40 F - 304 F
IAT	C, F	-40 C - 151 C, -40 F - 304 F
MAP	kPa / Volts	8-207 kPa, 0.00 - 4.98 volts
Baro	kPa / Volts	8-207 kPa, 0.00 - 4.98 volts
TP Sensor	Volts	0.00 - 4.98 volts
Throttle Angle	Percent	0 - 100%
Injector A Pulse Width	Milliseconds	0.0 - 500 ms
Injector B Pulse Width	Milliseconds	0.0 - 500 ms
Spark Advance	Degrees	-20 to 69.6484
Cam Retard	Degrees	0 to 90
Knock Retard	Degrees	0 to 89.6484
KS System Enabled	Yes/No	Yes/No
Knock Signal	Yes/No	Yes/No
IAC Position	Counts	0-255 counts
IAC Throttle Follower	Counts	0-255 counts
Closed Throttle	Yes/No	Yes/No
Vessel Speed	MPH	0-255
Battery Ignition Voltage	Volts	0.0 to 25.5
System Voltage Warning	Discrete	OK/Low Voltage
J1-20 Input	Discrete	On/Off
J2-20 Input	Discrete	On/Off
Emergency Stop Mode	Discrete	On/Off
Troll RPM Limit	Discrete	On/Off
Malfunction Indicator Lamp	Discrete	On/Off
Fuel Pump Relay	Discrete	On/Off
Cause Power Reduction	Discrete	On/Off
Power Reduction	Discrete	Yes/No
Overheat Detection	Discrete	Yes/No

Whipple Charger Installations Instructions for Mercury 454/502 Magnum Engines

Engine Scan Tool List (cont'd)

Scan Tool Parameter	Units	Parameter Range
Oil Pressure Input	Discrete	OK/Low Press
J1-9 Output	Discrete	On/Off
Oil Level Input	Discrete	OK/Low
Buzzer	Discrete	On/Off
J1-19 Input	Discrete	On/Off
J1-22 Output	Discrete	On/Off
J1-4 Input	Discrete	On/Off
J1-23 Output	Discrete	On/Off
Master/Slave	Discrete	Master/Slave
J1-7 RPM Output	Discrete	On/Off
Time From Start	Hour:Minutes:Seconds	00:00:00 - 18:12:15
Engine Hour Meter	Hours	0.0 - 1193046,47 hours
Fuel Consumption	Gallons per hour	0.0 - 255 gph
Fuel Pressure Volts	Volts	0.00 - 5.00 volts
Low Fuel Pressure Warning	Discrete	OK/Low Pressure
Fuel Temp	Volts	0-5 volts

Whipple Charger Installations Instructions for Mercury 454/502 Magnum Engines

CLOSED THROTTLE - Scan Tool Displays "YES" or "NO" - Indicates whether the throttle is in the closed position.

VESSEL SPEED - Scan Tool Range 0-255 MPH - Indicates the speed of the vessel in MPH.

BATTERY / IGNITION VOLTAGE - Scan Tool Range 0.0 - 25.5 volts - This represents the system voltage

SYSTEM VOLTAGE WARNING - Scan Tool Displays "OK" or "LOW VOLTAGE" - Indicates if there may be a fault in the charging system.

J2-9 INPUT - Scan Tool Displays "ON" or "OFF" - This is a discrete input to the ECM that is determined and calibratable per OEM.

J2-20 INPUT - Scan Tool Displays "ON" or "OFF" - This is a discrete input to the ECM that is determined and calibratable per OEM.

EMERGENCY STOP MODE - Scan Tool Displays "YES" or "NO" - Indicates whether you are in emergency stop mode or not.

TROLL RPM LIMIT - Scan Tool Displays "ON" or "OFF" - This is a discrete input to the ECM which limits the RPM for such things as trolling. This RPM limit is calibratable by the OEM.

MIL - Scan Tool Displays "ON" or "OFF" - Indicates the ECM commanded state of the Malfunction Indicator Lamp.

FUEL PUMP RELAY - Scan Tool Displays "ON" or "OFF" - Indicates the ECM commanded state of the fuel pump relay driver circuit.

CAUSE POWER REDUCTION - Scan Tool Displays "YES" or "NO" - Indicates whether or not the ECM has recognized a fault which would put the engine into Power Reduction when the appropriate RPM is achieved.

POWER REDUCTION - Scan Tool Displays "YES" or "NO" - Indicates whether or not the ECM is functioning in Power Reduction mode. During this mode, the ECM only triggers one injector driver resulting in fuel to only half of the cylinders.

OVERHEAT DETECTED - Scan Tool Displays "YES" or "NO" - Indicates if the ECM has recognized an overheat condition with the engine.

OIL PRESSURE WARNING - Scan Tool Displays "OK" or "LOW PRESSURE" - Indicates if the ECM has recognized a fault in the oil pressure circuit.

CHECK GAUGES LAMP - Scan Tool Displays "ON" or "OFF" - Indicates the ECM commanded state of the Check Gauges lamp.

BUZZER - Scan Tool Displays "ON" or "OFF" - Indicates the ECM commanded state of the Buzzer.

GENERAL WARNING 1 - Scan Tool Displays "OK" or "Fault Detected" - This is a discrete input to the ECM that is determined and calibratable per OEM.

J1-21 OUTPUT - Scan Tool Displays "ON" or "OFF" - Indicates the ECM commanded state of this output circuit.

GENERAL WARNING 2 - Scan Tool Displays "OK" or "Fault Detected" - This is a discrete input to the ECM that is determined and calibratable per OEM.

J1-22 OUTPUT - Scan Tool Displays "ON" or "OFF" - ECM driven output that is determined and calibratable per OEM.

ECM MASTER / SLAVE - Scan Tool Displays "MASTER" or "SLAVE" - Indicates whether you are receiving data from a master or a slave engine.

J1-8 RPM OUTPUT - Scan Tool Displays "ON" or "OFF" - ECM driven output that is determined and calibratable per OEM.

TIME FROM START - Scan Tool Range 00:00:00-99:99:99 Hrs:Min:Sec - Indicates the amount of time the ignition key was in the "ON" or "RUN" position. Once the key has been cycled to the "OFF" position, this counter will reset to 00:00.

ENGINE HOUR METER - Scan Tool Range 00:00:00-99:99:99 Hrs:Min:Sec - Indicates the engine run time.

ECM Diagnostic Trouble Codes

The Malfunction Indicator Lamp (MIL) will be "ON" if the malfunction exists under the conditions listed below. If the malfunction clears, the lamp will go out and the Diagnostic Trouble Code (DTC) will be stored in the ECM. Any DTC's stored will be erased if no problem re-occurs within 50 engine starts. The amount of time after the malfunction occurs before the MIL illuminates is calibratable. (Instantly or up to one minute).

Many of the DTC tables include a functional check of the system that may pinpoint a problem. However, it is important to remember that the DTC tables are specifically designed for use only when a DTC is set. Therefore, a thorough understanding of the normal operation of the system being diagnosed is necessary, and use of the tables for this purpose is at the discretion of the technician.

NOTICE: Some DTC's are referred as "Latching Codes." A latching code will cause the MIL lamp to stay "ON" during an ignition cycle whether the malfunction is corrected or not. This also means you can not clear the DTC during the same ignition cycle.

Diagnostic Trouble Code (DTC) Table

DTC	Description
13	Oxygen Sensor Circuit 1 (inactive)
13	Oxygen Sensor Circuit 2 (inactive)
14	Engine Coolant Temperature (ECT) Sensor Circuit. Low Temperature Indicated
15	Engine Coolant Temperature (ECT) Sensor Circuit High Temperature Indicated
21	Throttle Position (TP) Sensor Circuit High Signal Voltage Indicated
22	Throttle Position (TP) Sensor Circuit Low Signal Voltage Indicated
23	Intake Air Temperature (IAT) Sensor Circuit Low Temperature Indicated
24	Not Used
25	Intake Air Temperature (IAT) Sensor Circuit High Temperature Indicated
31	Not Used
33	Manifold Absolute Pressure (MAP) Sensor Circuit High Signal Voltage Indicated
34	Manifold Absolute Pressure (MAP) Sensor Circuit Low Signal Voltage Indicated
41	Ignition Control (IC) H Fault
41	Ignition Control (IC) G Fault
41	Ignition Control (IC) F Fault
41	Ignition Control (IC) E Fault
41	Ignition Control (IC) D Fault
41	Ignition Control (IC) C Fault
41	Ignition Control (IC) B Fault
41	Ignition Control (IC) A Fault
44	Knock Sensor (KS) 1 Circuit
44	Knock Sensor (KS) 2 Circuit
51	Calibration Checksum Failure
54	Not Used

Diagnostic Trouble Code (DTC) Table (cont'd)

DTC	Description
55	Not Used
61	Not Used
62	Not Used
63	Not Used
64	Not Used
81	Crankshaft Position (CKP) Sensor Circuit Fault
81	Camshaft Position (CMP) Sensor Circuit Fault
81	Injector Driver A Circuit High, Low, Open
81	Injector Driver B Circuit High, Low, Open
81	Recirc J1-32 Fault
81	5 Volt Reference Circuit Out of Range
81	DEPSPWR Circuit out of Range
81	CAN Bus Fault

Logged Warnings

These warnings will be displayed following the Diagnostic Trouble Codes. They can be cleared the same as the trouble codes. Unlike trouble codes, these warnings can not be flashed out through the MIL using the DTC tool.

Clearing Diagnostic Trouble Codes - Non Scan

1. Install Diagnostic Trouble Code (DTC) tool.
2. Ignition "ON," engine "OFF."
3. Switch DTC tool to "service mode" or "ON."
4. Move the throttle from 0% (idle) to 100% (WOT) and back to 0%.
5. Switch DTC tool to "normal mode" or "OFF" (If this step is not performed, the engine may not start and run).
6. Turn ignition "OFF" for at least 20 seconds.
7. Ignition "ON," engine "OFF."
8. Switch DTC tool to "service mode" or "ON" and verify DTC 12 only. Remove MDTC tool.
9. If original DTC's are still present, check "Notice" below and repeat the DTC clearing procedure.
10. If new DTC's are displayed, perform the "On-Board Diagnostic" (OBD) system check.

Clearing Diagnostic Trouble Codes - Scan

1. Install scan tool.
2. Start engine.
3. Select "Clear DTC's" function.
4. Clear DTC's.
5. Turn ignition "OFF" for at least 20 seconds.
6. Turn ignition "ON" and read DTC's. If DTC's are still present, check "Notice" below and repeat procedure following from step 2.

NOTICE: When clearing DTC's with or without the use of a scan tool, the ignition must be cycled to the "OFF" position or the DTC's will not clear.

General Information

All Delco Distributor Ignition (DI) systems include these essential components: battery, distributor, ignition coil, ignition switch, spark plugs, and primary and secondary wiring. The Distributor Ignition (DI) system is connected to the Engine Control Module (ECM). The ECM monitors various engine sensors, computes the desired spark timing and signals the Ignition Control module in the distributor to change timing. The distributor does not contain centrifugal advance weights, springs, or vacuum advance units.

1 The distributor used on marine Electronic Fuel Injection equipped engines is designed for the marine environment. The distributor base plate is equipped with two special vents to prevent fuel vapors from igniting.

The ignition coil connects to the distributor through a high tension secondary wire and two low voltage primary wires. Due to the high voltage produced by the coil, a special material is used for the distributor cap and rotor. It is a thermoplastic, injection molded, glass reinforced polyester. This material provides the required dielectric and insulation property, and also prevents carbon tracking. The posts in the distributor cap are made up of durable metals to prevent corrosion.

1 The distributor uses an internal magnetic pickup assembly that consists of a permanent magnet, pole piece with internal teeth, and a pickup coil. The pickup coil is sealed to keep out moisture and prevent electromechanical interference. When the rotating teeth of the timer core line up with the teeth of the pole piece, voltage is induced in the pickup coil. This voltage signals the Ignition Control module to trigger the primary ignition circuit. Current flow in the primary circuit is interrupted and high voltage of up to 35,000 volts is induced in the ignition coil secondary winding. This high voltage is directed through the secondary ignition circuit to fire the spark plugs.

The number of teeth on the stationary pole piece, and on the timer core's rotating shaft, reflects the number of cylinders in the engine (i.e. 8 teeth for eight cylinders). Although there are minor differences between applications, all DI systems operate the same.

There is no scheduled maintenance or periodic lubrication required. Engine oil lubricates the lower bushing, and the upper bushing is pre-lubricated and sealed.

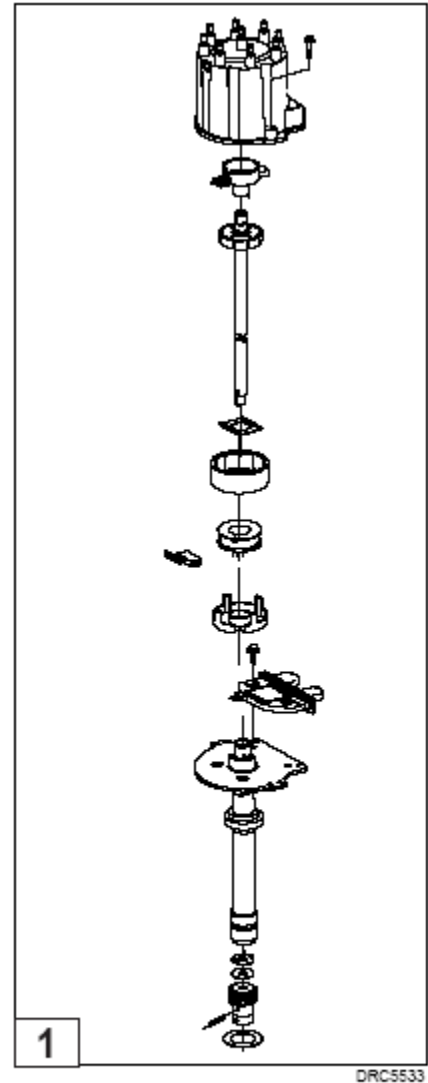

DISASSEMBLY

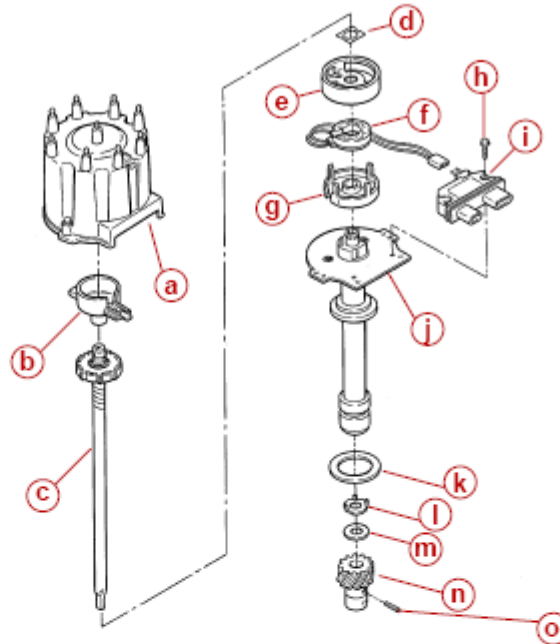

72411

- a - Cap
- b - Rotor
- c - Shaft Assembly
- d - Retainer
- e - Shield
- f - Pickup Coil
- g - Pole Piece
- h - Screw
- i - Module
- j - Housing
- k - Gasket
- l - Tang Washer
- m - Washer
- n - Gear
- o - Pin

NOTE: Whenever disassembling distributor, the retainer (d) must be replaced. DO NOT attempt to use old retainer.

Ignition Coil

The design and construction of the ignition coil affects its output. The DI system ignition coil was designed to produce greater spark voltage, longer spark, and operate at higher RPM. The DI system coil has the secondary windings wrapped around the primary windings. The primary windings are wrapped around an iron core. The coil is not oil filled. The windings are covered in an epoxy compound for protection against moisture and arc-over.

There is an iron laminated square frame around the coil windings. This increases the magnetic flux path and stores energy to produce higher secondary spark voltage. The coil's mounting bracket is attached to the frame.

2 The coil generates a high secondary voltage (up to 35,000 volts) when the primary circuit is broken. It is attached to the distributor by a high tension wire connected to the post **Ⓐ** mounted on top of the coil. The coil has a pair of 2-wire connectors. They're used for battery voltage input **Ⓒ**, primary voltage sent to the distributor Ignition Control module **Ⓓ**, trigger signal from the Ignition Control module **Ⓔ**, and for a tach output signal **Ⓕ**.

Ignition Control (IC) Module

3 The Ignition Control (IC) module is located in the distributor. It is mounted by two screws that are used for a ground. The IC module is a solid state unit with transistorized relays and switches for controlling circuits. The IC module has several functions:

- It changes the analog signal **Ⓐ** of the pickup coil to a square digital signal.
- It sends the digital signal as a reference signal (REF HI) **Ⓑ** to the ECM for ignition control.
- It provides a ground reference (REF LO) **Ⓒ**.
- It provides a means for the ECM to control spark advance (BYPASS **Ⓓ** and IGNITION CONTROL **Ⓔ**) called Ignition Control Mode.
- It provides a limited means of controlling spark advance without ECM input, called Module Mode.
- It provides the trigger signal **Ⓕ** for the ignition coil.

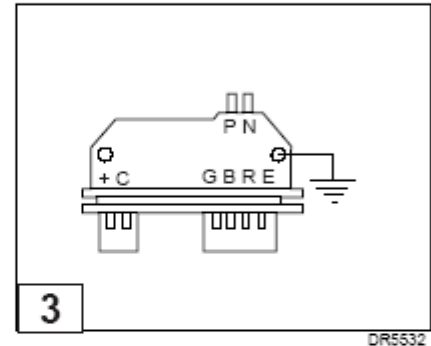
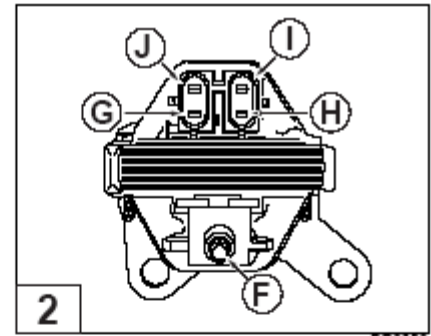

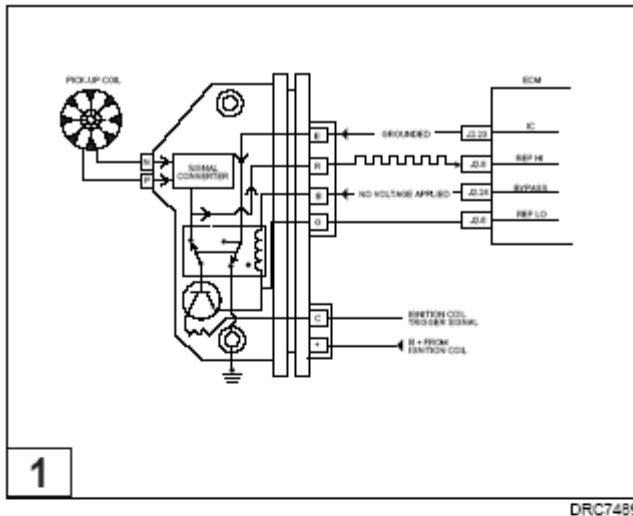

IC Operation - Module Mode (Cranking)

1 The following describes IC operation during cranking and when the engine starts running. To help understand how IC circuits operate, a relay with a double set of contact points is shown inside the IC module. Actually solid state circuitry is used, but showing a relay makes it easier to visualize how the IC functions.

1 During cranking, the relay is in a de-energized position. This allows a set of contact points to connect the pickup coil to the base of the transistor. When the pickup coil applies a positive voltage to the transistor, it turns "ON". When voltage is removed, the transistor turns "OFF". When the transistor turns "ON", current flows through the primary windings of the ignition coil. When it turns "OFF", the primary current stops and a spark is developed at the spark plug. A small amount of advance is built into the IC module, in case the engine remains in Module Mode.

1 With the relay de-energized, a set of contacts (shown "closed") would ground the IC line signal. No voltage is applied by the ECM to the BYPASS line.

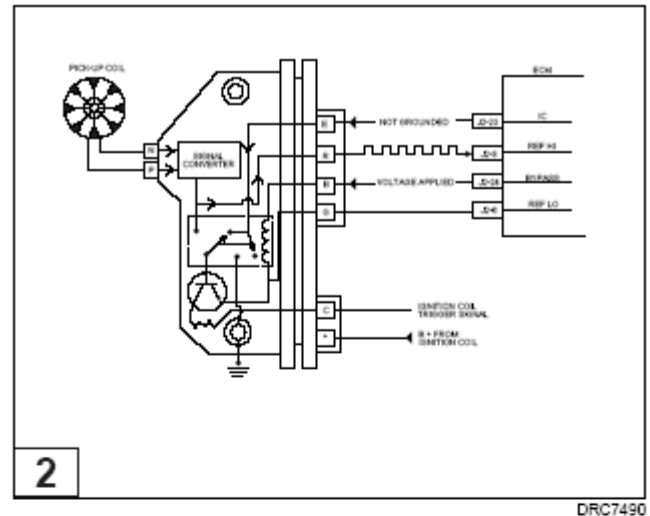

IC Operation - Ignition Control Mode (Running)

2 The ECM constantly monitors engine RPM through the REF HI line. When engine RPM reaches a predetermined value (for this example 400 RPM), the ECM considers the engine running and applies five volts on the BYPASS line to the IC module. This energizes the relay and causes contact set for the pickup coil as well as contact set for the IC line to open. This connects the IC line to the base of the power transistor, and bypasses IC module timing control.

The DI system is now controlled by the timing (IC) signal from the ECM, and the time at which the spark occurs can be determined by a variable time circuit in the ECM.

Results Of Incorrect Operation_____

An open or ground in the BYPASS circuit or connector will cause the engine to run in Module Mode. This will cause reduced performance and poor fuel economy.

Open IC Line

While the engine is cranking, the ECM expects to see the IC signal pulled to virtually zero because it's grounded inside the IC module. If the IC line is open, it cannot be grounded by the module. The ECM IC signal will be able to rise and fall, or do what is called "toggling". The ECM recognizes "toggling" as an abnormal condition, and will not apply bypass voltage to the IC module when the engine reaches run RPM.

Since bypass voltage is not applied to the relay, it remains open. The engine continues to run on pick-up coil triggering, and stays in Module Mode. If this condition were to occur while the engine was running, the engine would stop, but it would restart and run in Module Mode with reduced power.

Grounded IC Line

During cranking, IC voltage would be at virtually zero so the ECM would not recognize a problem. When engine RPM reaches the value for the run condition, the ECM would apply bypass voltage to the IC module. Bypass voltage at the module switches the IC power transistor to the IC line. Because the IC line is grounded, it would have no voltage applied and could not operate the power transistor in order to enter Ignition Control Mode.

If the IC line should become grounded while the engine was running, the engine would stop and be difficult to restart.

Grounded Or Open BYPASS Line

While the engine is cranking, the IC line would be grounded and the ECM would not notice anything abnormal. When run RPM is reached, the ECM would apply voltage to the BYPASS line but because of the ground or open, it would not be able to energize the relay. Therefore, the relay would stay de-energized and the IC line would remain grounded.

When the ECM sees the IC line not "toggling" (i.e. not rising and falling), it will not enter Ignition Control Mode. Since the relay is de-energized, the engine would continue to run in Module Mode.

If this condition were to occur while the engine was running, it would simply operate in Module Mode.

Open Or Grounded REF Hi Line

This line provides the ECM with engine speed (RPM) information. If this line were open or grounded, the ECM would not know that the engine is cranking or running, and would not make any attempt to control spark.

Open Or Grounded REF LO Line

This wire is grounded in the IC module and provides a reference ground from the IC module to the ECM. The ECM compares reference ground with reference high voltage. If this circuit is open, or grounded at any other location than through the IC module, it may cause poor performance.

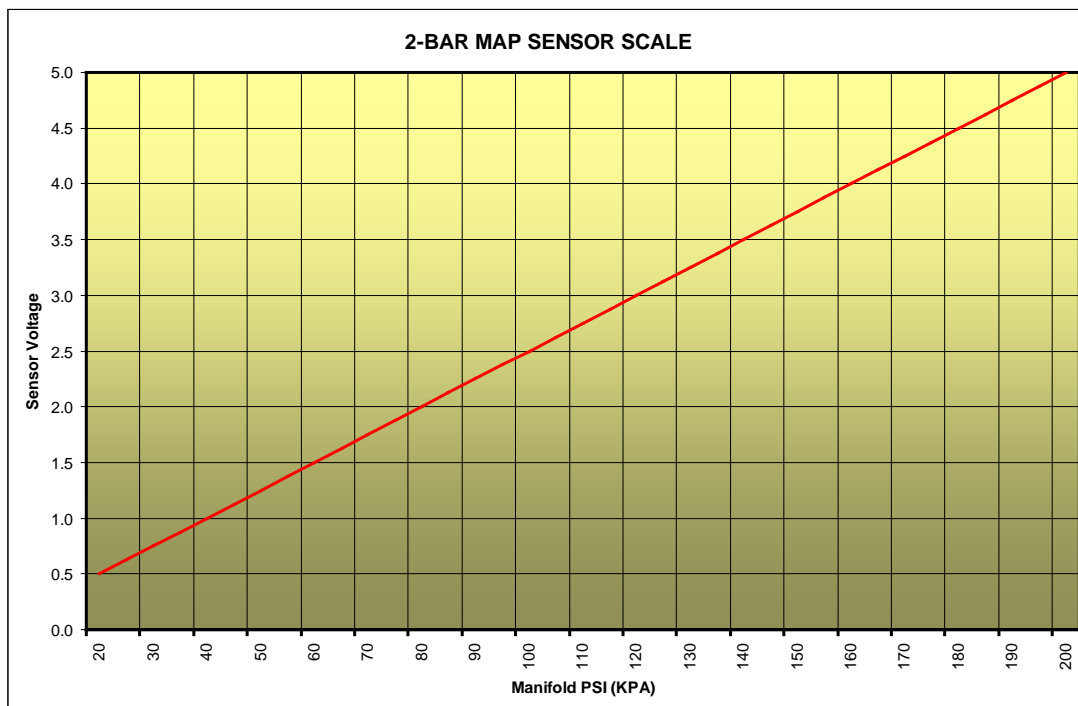



LIMITED WARRANTY

All merchandise manufactured by Whipple Industries is fully warranted against defects in workmanship and materials to the original purchaser of the Whipple Supercharger System. The limited warranty must be signed, dated and returned to Whipple Industries within 14 days of the purchase date accompanied by a copy of the original sales invoice.

If an item is suspected of being defective, return it to Whipple Industries for inspection after obtaining the proper Return Authorization Number. If an item is determined to be defective, we will repair or replace it at our discretion within a period of one year from the shipping date on your invoice.

Whipple Industries Inc. limited warranty specifically does not apply to products which have been (a) modified or altered in any way, (b) subjected to adverse conditions such as misuse, neglect, accident, improper installation or adjustment, dirt, or other contaminants, water, corrosion or faulty repair; or (c) used in other than those specifically recommended by Whipple Industries Inc. All products designed for off-road use are considered racing parts and carry no warranty, either expressed or implied, as we have no control over how they are used.

On warranty items, repair/replacements will be limited to parts manufactured by Whipple Industries and will not include claims for labor or inconvenience. All other merchandise distributed by Whipple Industries is warranted in accordance with the respective manufacturer's own terms of warranty. This warranty is expressly made in lieu of any and all other warranties expressed or implied, including the warranties of merchantability and fitness.

Whipple Industries will not be responsible for any other expenses incurred by the customer under the terms of this warranty, nor shall it be responsible for any damages either consequential, special, contingent, expenses or injury arising directly or indirectly from the use of these products.

Whipple Industries reserves the right to determine whether the terms of the warranty, set out above, have been properly complied with. In the event that the terms are not complied with, Whipple Industries shall be under no obligation to honor this warranty. By signing this form, you understand and agree to the terms above.

NAME (Print) _____ ADDRESS _____

SIGNATURE _____ CITY _____ STATE _____ ZIP _____

DATE _____ PHONE _____

SC SERIAL # _____ EMAIL _____
(Found on compressor bearing plate) (Optional)

VIN OR VESSEL # _____