



## **WHIPPLE *SUPERCHARGER* INSTALLATION MANUAL**

**2014-2018 GM 5.3L/6.2L LT1 TRUCK**

**2014-2020 GM 5.3L/6.2L LT1 SUV**

**PART NUMBER: WK-1200, WK-1201, WK-1250, WK-1251**

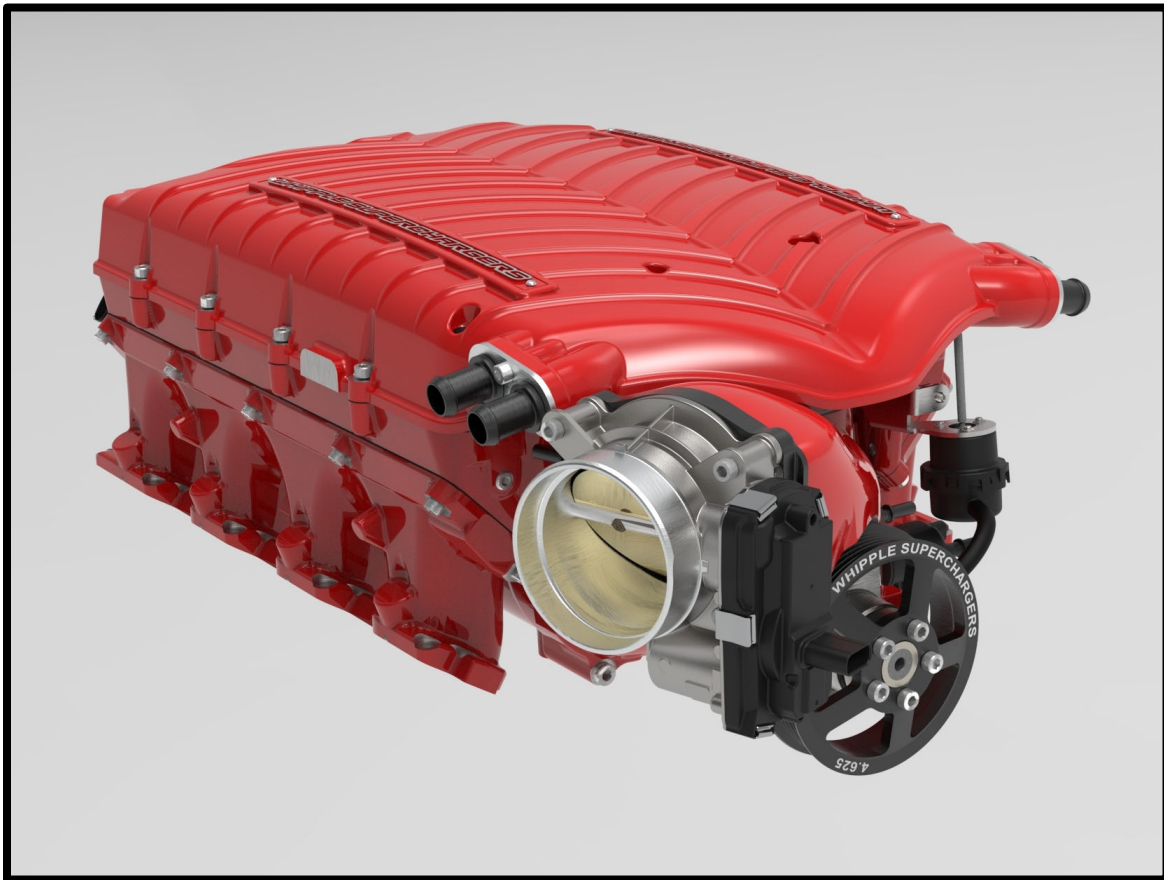

**WHIPPLE SUPERCHARGERS**

**3292 NORTH WEBER AVE**

**FRESNO, CA 93722**

**TEL 559.442.1261**

**FAX 559.442.4153**

**[WWW.WHIPPLESUPERCHARGERS.COM](http://WWW.WHIPPLESUPERCHARGERS.COM)**

**PREMIUM FUEL ONLY (91 OCTANE OR BETTER ALWAYS) RON+MON/2**

**CALIFORNIA AIR RESOURCE BOARD EXECUTIVE ORDER #D-231-65**

---

## **INTRODUCTION**

Before beginning installation, please read this manual and important notes:

- Please read the installation manual and verify that all items are present. If you are missing hardware or have any questions, please contact your dealer or Whipple Superchargers before you start the installation.
- Modifications to your Fascia and Grill can greatly affect performance. Other aftermarket parts may also create issues. The SC system is designed for stock vehicles.
- Premium fuel (US 91 octane) is required to prevent spark-knock/detonation under certain operating conditions. Other countries must meet US 91 octane standards, RON+MON/2. **If fuel of less than 91-octane is present in the vehicle fuel tank, the tank must be completely drained and refilled with 91 or higher octane to 1/8<sup>th</sup> of a tank. The fuel system is returnless, therefore, initial fuel in the system will be low octane. Drain all fuel!**
- Operating your engine without the Whipple Calibration can result in engine damage or failure and will void your warranty.
- Supply your VIN number (along with gear ratio, transmission type, throttle body type and any changes to vehicle) to Whipple ahead of time so your unique PCM calibration can be built prior to the SC installation to minimize any down time. **NOTE:** Whipple does not support long tube headers or cat removal. While the vehicle may run correctly, it will no longer be emissions legal and therefore not supported.
- **NEVER MANUALLY MOVE THE BYPASS ACTUATOR, YOU CAN RUPTURE THE INTERNAL DIAPHRAM.**

**COMPETITION BASED PRODUCT MAY BE USED SOLELY ON VEHICLES USED IN SANCTIONED COMPETITION WHICH MAY NEVER BE USED UPON A PUBLIC ROAD OR HIGHWAY, UNLESS PERMITTED BY SPECIFIC REGULATORY EXEMPTION (VISIT THE "EMISSIONS" PAGE AT [HTTP://WWW.SEMASAN.COM/EMISSIONS](http://www.semasan.com/emissions) FOR STATE BY STATE DETAILS.**

**COMPETITION BASED PRODUCT IS LEGAL IN CALIFORNIA ONLY FOR RACING VEHICLES WHICH MAY NEVER BE USED, OR REGISTERED OR LICENSED FOR USE, UPON A HIGHWAY.**

**IT IS THE RESPONSIBILITY OF THE INSTALLER AND/OR USER OF THIS PRODUCT TO ENSURE THAT IT IS USED IN COMPLIANCE WITH ALL APPLICABLE LAWS AND REGULATIONS.**

## **RECOMMENDED TOOLS AND SUPPLIES**

The following items are not included in this supercharger kit and it is strongly recommended that they're used for ease of installation or maximum performance:

### **Tools**

1/4" and 3/8" torque wrenches. Safety glasses, metric wrench set, electric or air drill, 1 1/2" hole-saw, hack saw, 1/4", 3/8", 1/2" assorted metric socket set, 5mm ball head allen, 3/8" assorted metric allen socket set, 3/8" assorted torx socket set, 8mm hex allen wrench, 1/2" breaker bar, flat head and Philips screw drivers and drain pan (for coolant). Electric tape. Trim pad tool (for pushpin removal). Clean shop towels.

### **Tie Straps**

These will be useful for securing the wiring harness away from the installation area as directed in the instruction manual. They are inexpensive and will be very handy during installation. You will need an assortment of 4", 8" and 12".

### **Sealants, Chemicals and Lubricants**

Anti-seize for bolt and spark plug threads (use only when stated, otherwise the torque value must be reduced). Assembly lubricant (white lithium grease or petroleum jelly). Cleaner/degreaser such as carb cleaner. Blue Loctite #243 or equivalent.

You'll be required to fill your intercooler system with approximately 2 gallons of distilled water and OEM rated engine coolant. This is not supplied in the system, you can find the coolant at any local auto parts store, any OEM rated coolant will work. **NEVER USE TAP WATER**, as it can corrode and create poor performance.

## **PRE-INSTALLATION CHECKLIST**

Before installing your Whipple Supercharger Kit, complete the following checklist.

1. Verify Condition of Vehicle: Before the supercharger kit is installed, ensure the engine runs smoothly and that the factory malfunction indicator light (MIL) is off. Only install the supercharger kit if the engine runs smoothly *and* the MIL is off.
2. **!! CAUTION !!** This product is intended for use only on **STOCK, UNMODIFIED, WELL-MAINTAINED** engines. Installation on a worn-out engines or modified vehicles is not recommended. Custom configurations can greatly affect the operation of the vehicle. Vehicles with reasonably high mileage (75,000) may have factory parts that are worn or deteriorated. It's very important to monitor all activity pre and post to ensure proper operation. Items such as the fuel pump, fuel filter, ignition coils, exhaust system, body mounts, transmission, etc may all have signs of wear and thus, create issues with the added power.
3. Modifications to your stock vehicle including, but not limited to engine, flywheel, clutch, torque converter, transmission, wheels, tires, axles, gears, driveshafts, air intake systems, exhaust system, additional weight and aftermarket electronics can have a significant impact on your vehicles operation. It is impossible for us to develop all possible variations and combinations. All vehicle and supplemental warranties are based off stock vehicle configurations. It is the sole responsibility of the customer making a warranty claim to prove that any vehicle modifications were within warranty. It is also the sole responsibility of the customer to determine if the modifications comply with all local, state and federal emission standards.
4. **!! CAUTION !!** Use only 91 octane fuel or higher. If fuel of less than 91-octane is present in the vehicle fuel tank, the tank must be completely drained and refilled with 91 or higher octane to 1/8<sup>th</sup> of a tank.
5. Verify Fuel System: Supercharger systems should only be installed on vehicles that have new or clean fuel filters.
6. Assess Cleanliness of Installation Area: Make sure your work area and the under-hood area are free from debris. This supercharger is a high-quality, close-tolerance compressor and must not be subjected to contamination by dirt or any type of foreign material. If necessary, vacuum around engine to remove any foreign material.
7. **!! CAUTION !! DO NOT** remove the protective seal on the supercharger prior to installation. Foreign material entering the supercharger will automatically void all warranties.
8. Identify Supercharger Kit Components: Before beginning installation, identify all the components of your Whipple Supercharger Kit and ensure all items are present and undamaged.
9. **!! CAUTION !!** Do not attempt to start the engine before adding the supplied Supercharger Oil to the supercharger!

## **SAFETY PRECAUTIONS**



**CAREFULLY READ THE IMPORTANT SAFETY PRECAUTIONS AND WARNINGS BEFORE PROCEEDING WITH THE INSTALLATION!**

Appropriate disassembly, assembly methods and procedures are essential to ensure the personal safety of the individual performing the kit installation. Improper installation due to the failure to correctly follow these instructions could cause personally injury or death. Read each step of the installation manual carefully before starting the installation.

- Always wear safety glasses for eye protection.
- Place the ignition switch in the off position.
- Always apply the parking brake when working on vehicle.
- Block the front and rear tire surfaces to prevent unexpected vehicle movement.
- Operate the engine only in well-ventilated areas to avoid exposure to carbon monoxide.
- Do not smoke or use flammable items near or around fuel system.
- Use chemicals and cleaners only in well-ventilated areas.
- Batteries can produce explosive hydrogen gas which can cause personal injury. Do not allow flames, sparks or flammable sources to come near the battery.
- Keep hands and any other objects away from the radiator fan blades.
- Keep yourself and you're clothing away from moving parts when the engine is running.
- Do not wear loose clothing or jewelry that can be caught in rotating or moving parts.

## **COMMON ABBREVIATIONS**

ABBREVIATION	DESCRIPTION
DTC	Diagnostic Trouble Code
ECT	Engine Coolant Temperature
EGR	Exhaust Gas Recirculation
ETC	Electronic Throttle Control
EVAP	Evaporative emissions system
FHSCS	Flat Head Socket Cap Screw
IAT	Inlet Air Temperature
IC	Intercooler
ID	Internal Diameter
LB-IN	Pound-force inch
LB-FT	Pound-force foot
LH	Left Hand Side (from driver seat)
LTR	Low temp radiator
MAF	Mass Air Flow
MAP	Manifold Absolute Pressure
MY	Model Year
OBD	On Board Diagnostics
OD	Outside Diameter
PCV	Positive Crankcase Ventilation
PSI	Pound per Square Inch
RH	Right Hand Side (from driver seat)
SC	Supercharger
SHCS	Socket Head Cap Screw
TPS	Throttle Pressure Sensor
TRQ	Torque



**\*\*NOTICE:** Installation of Whipple Supercharger products signifies that you have read this document and have agreed to the terms stated within.

*It's the purchaser's responsibility to follow all installation instruction guidelines and safety procedures supplied with the product as it's received by the purchaser to determine the compatibility of the product with the vehicle or the device the purchaser intends to install the product on.*

*Whipple Superchargers assumes no responsibility for damages occurring from accident, misuse, abuse, improper installation, improper operation, lack of reasonable care or all previously stated reasons resulting from incompatibility with other manufacturer's products.*

*There are no warranties expressed or implied for engine failure or damage to the vehicle in any way, loss of use or inconvenience or labor reimbursement. This includes merchantability and fitness.*

*The information contained in this publication was accurate and in effect at the time the publication was approved for printing and is subject to change without notice or liability. Whipple Superchargers reserves the right to revise the information presented herein or to discontinue the production of parts described at any time.*

- ⊗ NEVER SMOKE DURING THE INSTALLATION OF THE SC, THERE WILL BE FLAMMABLE FUMES AND LIQUID AROUND THE VEHICLE

## **INSTALLATION MANUAL**

It is strongly recommended that you read through this guide before you begin installing the Whipple Supercharger.

**⚠ WARNING!!** Batteries normally produce explosive gases. Therefore, do not allow flames, sparks or lighted substances to come near the battery. When charging or working near a battery, always shield your face and protect your eyes. Always provide ventilation. Failure to follow these instructions may result in personal injury.

**⚠ WARNING!!** Keep out of the reach of children. Batteries contain sulfuric acid. Avoid contact with skin, eyes or clothing. Also, shield your eyes when working near the battery to protect against possible splashing of the acid solution. In case of acid contact with the skin or eyes, flush immediately with water for a minimum of 15 minutes and get prompt medical attention. If acid is swallowed, call a physician immediately. Failure to follow these instructions may result in personal injury.

1. Follow the step-by-step calibration process instruction sheet. Software based issues need to be handled through HP Tuners, [support@hptuners.com](mailto:support@hptuners.com). **Note: Cals can take up to 48 business hours after request, this should always be done before installing the supercharger. Your computer must have a stock unaltered file. If you have a modified PCM, return it back to stock to avoid potential issues. If you do not have the stock file, you must take it to the dealership and have the PCM/TCM updated. Failure to do so may cause complications in the file build for your vehicle and cause running issues.**
2. Disable fuel pump control module by removing fuel pump fuse located in fuse box. Start vehicle and allow engine to run until the engine stops. Attempt to restart vehicle to ensure pressure has dropped.
3. Using an air hose, blow off any loose dirt or debris from engine compartment. If really dirty, then steam clean the engine compartment before proceeding to the next step.
4. Slowly remove the factory gas cap to relieve any excess pressure.
5. Disconnect the negative (-) battery connector with a 10mm wrench. The battery cable must remain off for the remainder of the install.
6. Drain the coolant from the radiator drain fitting located on the passenger side, bottom of radiator. Install a 3/8" ID rubber hose to end of petcock and route to storage container. Loosen the petcock to begin draining. Loosen the overflow tank cap to increase flow.
7. Disconnect the quick connect fittings located on both sides of the stock air induction tube. Disconnect by squeezing the clips and pulling away from ducting.

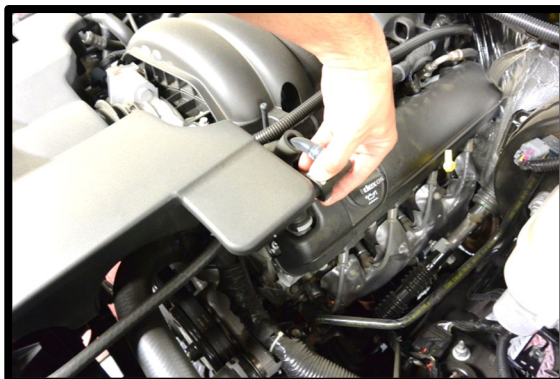
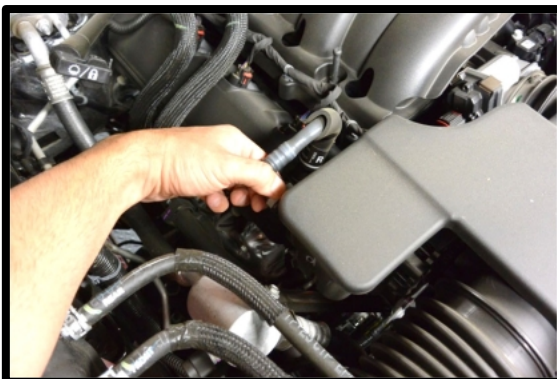

8. Disconnect the MAF sensor connector by pulling up on the red safety clip, and then squeezing the connector while pulling up.

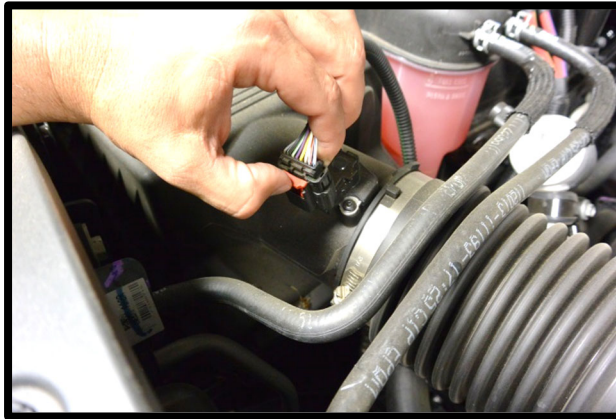

9. Loosen the hose clamp using an 8mm nut driver that secures the MAF housing to the stock air induction tube and the hose clamp holding the air induction tube to the throttle body. Lift the factory air ducting away from engine.

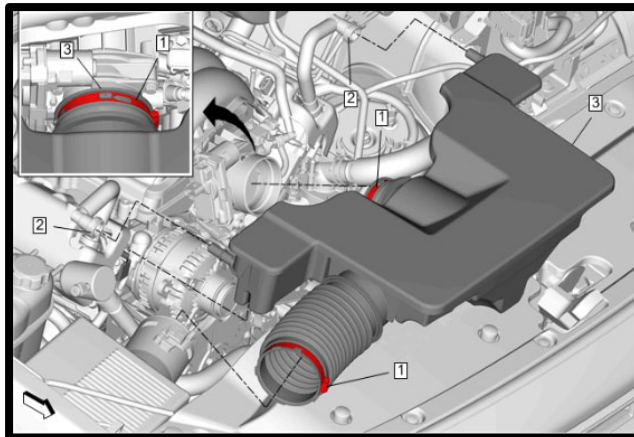

10. Remove the factory airbox lid by removing the (4) mounting bolts using an 8mm socket. Remove the stock air filter element, this will not be reused.

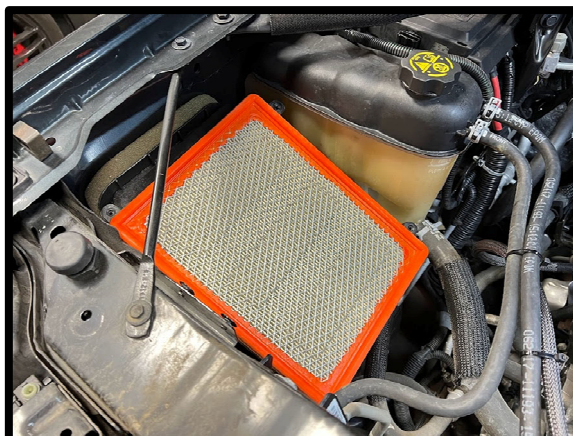
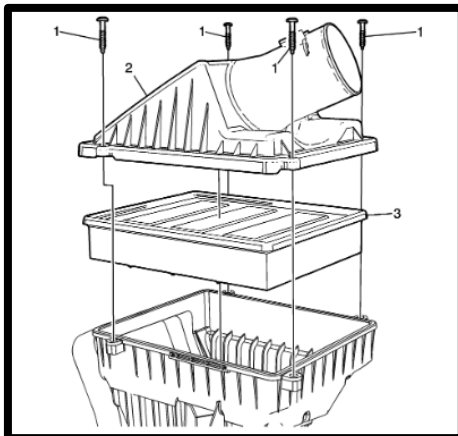

11. Disconnect the electronic throttle connector by pulling up on the red safety clip, and then squeezing the connector while pulling up.

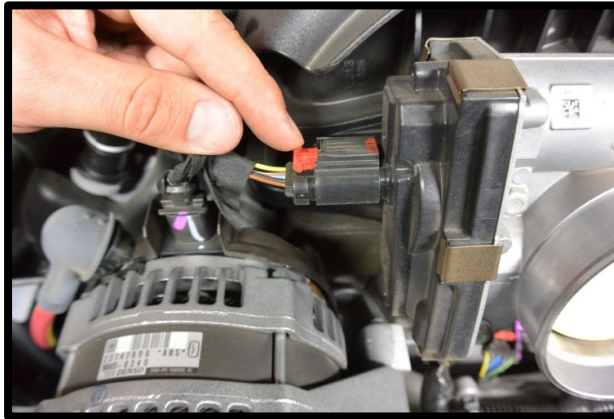

12. Disconnect the factory MAP sensor electrical connector by squeezing the connector and pulling away.



13. Disconnect the factory EVAP solenoid quick connection from solenoid by squeezing the connector and pulling away. Remove EVAP line from port at back of engine LH side. Remove the EVAP solenoid from the intake manifold using a 10mm socket and hang to the driver side of engine for later installation.

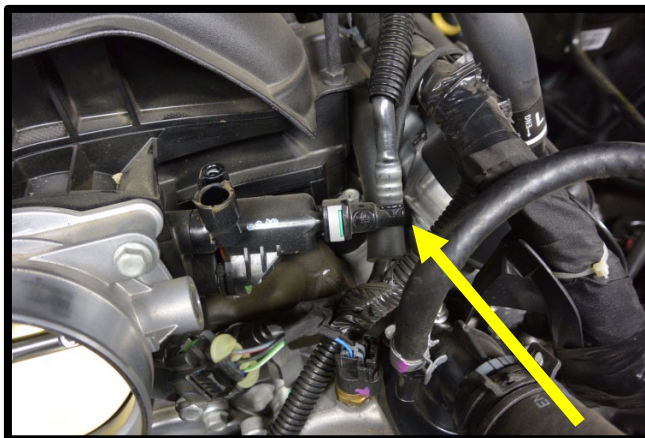

14. Remove the stock throttle body from the engine by removing the (4) fasteners using a 10mm socket.

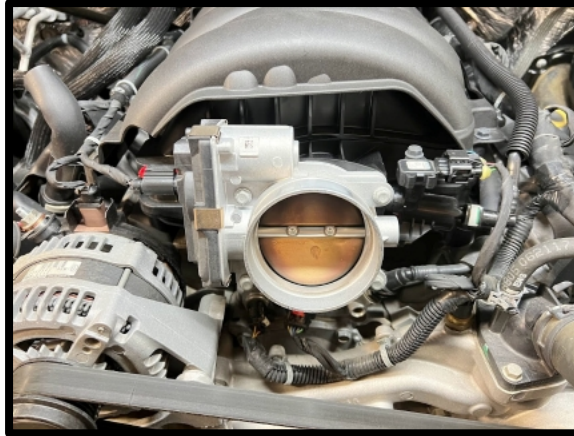

15. Remove the (2) air duct support stands from the intake manifold using a 10mm wrench or deep-well socket. Remove the (2) fasteners located in the back securing the intake manifold cover to the intake manifold using a 10mm socket.



16. Remove the valve cover to air duct plastic vent tubes from valve covers by squeezing the connector and pulling up.

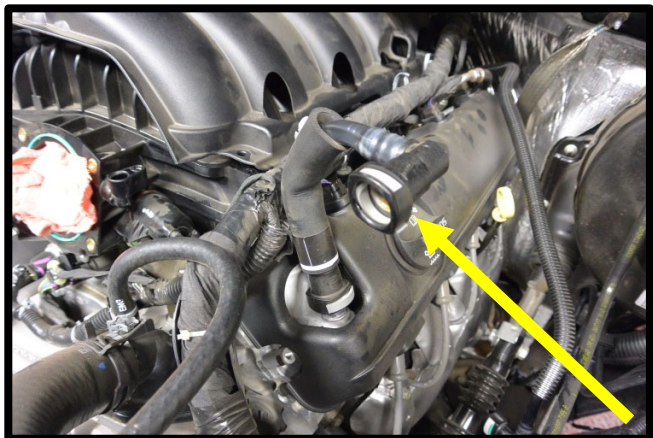
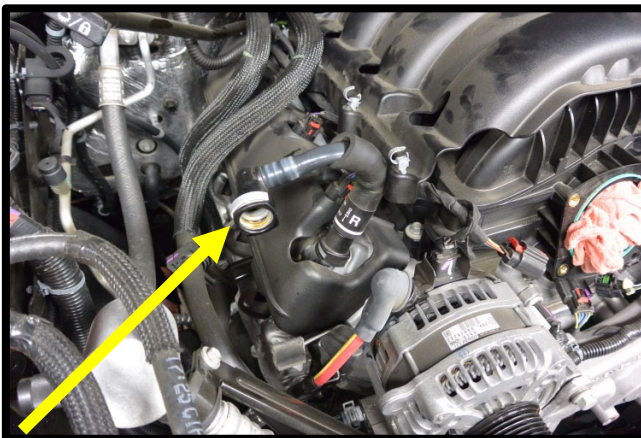

17. Remove the vent line from the valley tray to the manifold quick connect fitting by squeezing the connector and pulling away from intake manifold. Remove end from valley tray (this is in the way for manifold removal).



18. Remove the (8) cable ties securing the wire harness to the intake manifold cover (these will not be reused).

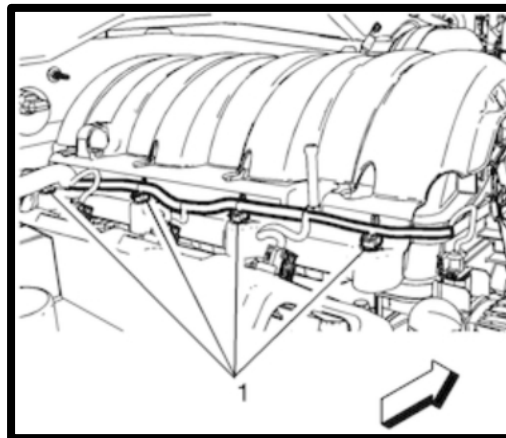

19. The plastic cover cannot be removed due to firewall clearance; therefore, you must loosen all the factory intake manifold bolts (10) using a 10mm socket. Remove the intake manifold by lifting and sliding forward. Once the intake manifold is out of the way, remove the plastic cover by removing the (4) plastic cable ties holding the wire harness to the back of the cover.

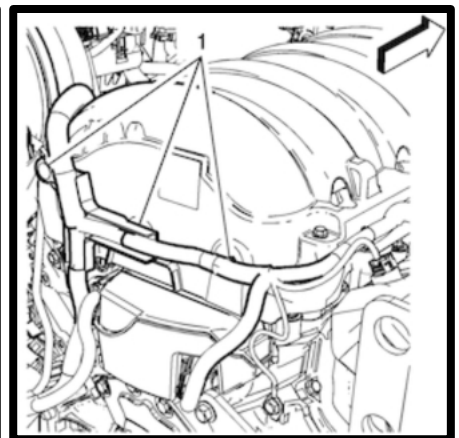
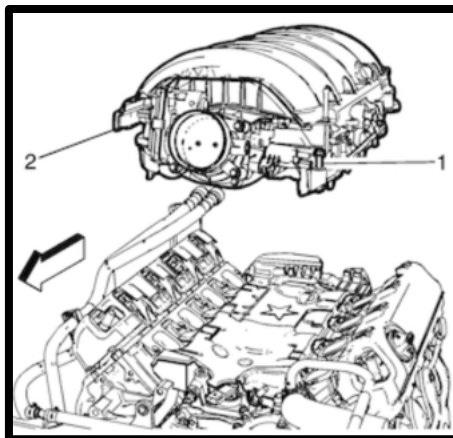
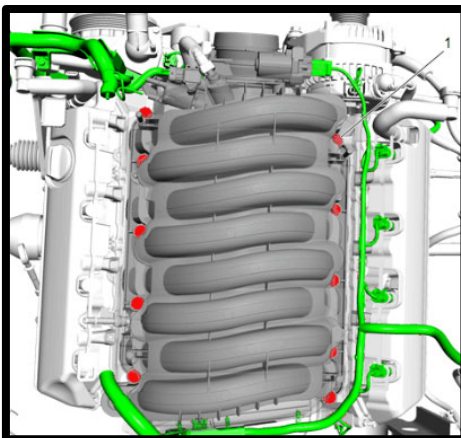

20. Clean the intake manifold surface using carb cleaner or other like chemicals. Cover intake ports with masking tape or duct tape. Remove the fuel pump foam insulator from valley of block.

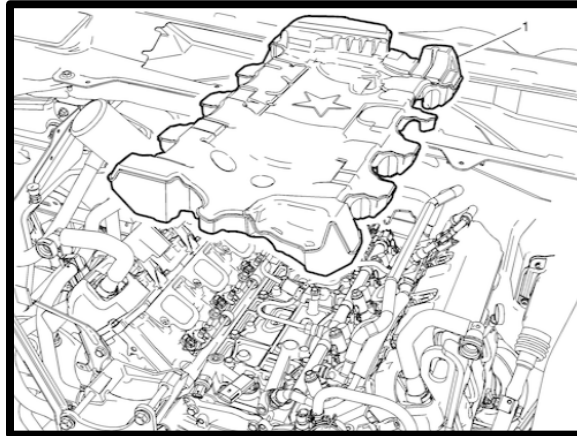

21. Using a 1/2" breaker bar or long 1/2" socket, remove the stock belt by releasing the tension of the factory spring loaded tensioner. Rotate in a counter-clockwise motion to release tension. Using a 15mm socket, remove the tensioner from engine.

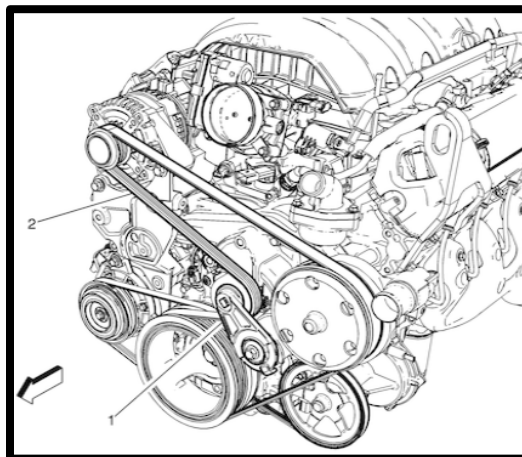

22. Carefully pull coil wires from spark plug (you can damage by pulling incorrectly). Remove the stock spark plugs & replace with the Denso ITV22 or NGK 6510. Gap the sparkplug at **.032"**. **NEVER CRUSH THE ELECTRODE!!** Torque the sparkplug to 11 ft-lbs as per GM manual, apply a small amount of anti-seize on the threads. **NOTE:** NGK plugs out of the box come at .052", this will set misfire codes if not gapped correctly.



23. **USE EYE PROTECTION:** Set shop rags or similar under stock feed line. Remove secondary safety locks from both sides of the stock jumper fuel line. Use the provided fuel line removal tool to release the stock feed line from jumper line. Slide the tool on the underside of the hose connection and press up on it while you push down on the hose. This will release the connection. Soak up extra fuel using shop rags. Dispose of rags once line is drained.

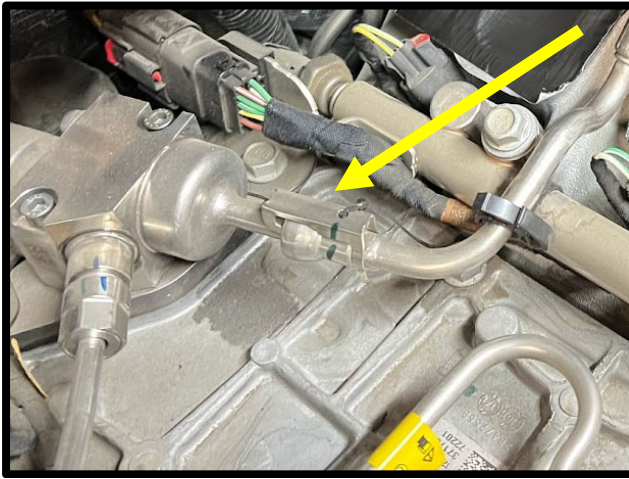

24. Using a 10mm socket, remove the stock bolt securing fuel line to motor. Disconnect the fuel feed pipe metal collar fittings from the fuel line. Remove DI pump feed hose. Keep stock fastener for later use.

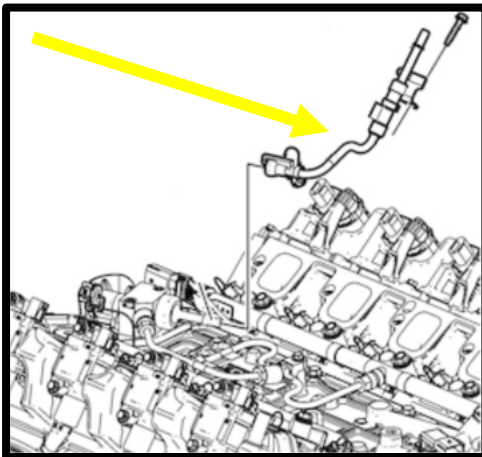

25. Disconnect the alternator 2-way connector. Remove the power wire by removing the nut at the alternator. Remove alternator from engine for SC installation by removing the (2) mounting bolts (15mm socket). Some applications have a support bracket for the AC lines. Remove temporarily.

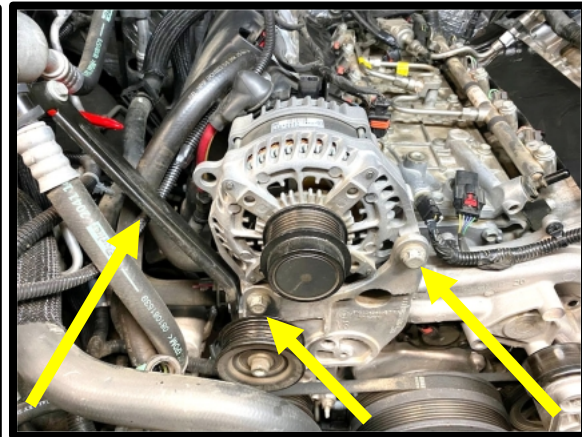

26. Remove the airbox support bracket from cylinder head, this will not be reused.

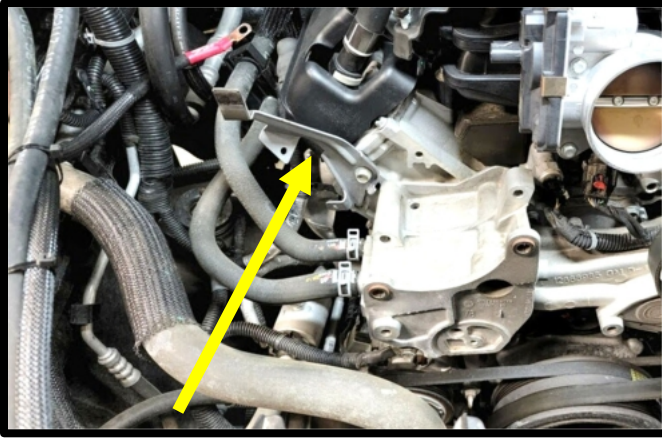

27. Disconnect coolant sensor 2-way connector. Remove vent line from thermostat housing by releasing pinch clamp. Remove thermostat housing outlet hose from thermostat housing by releasing pinch clamp. Remove coolant temp sensor temporarily.

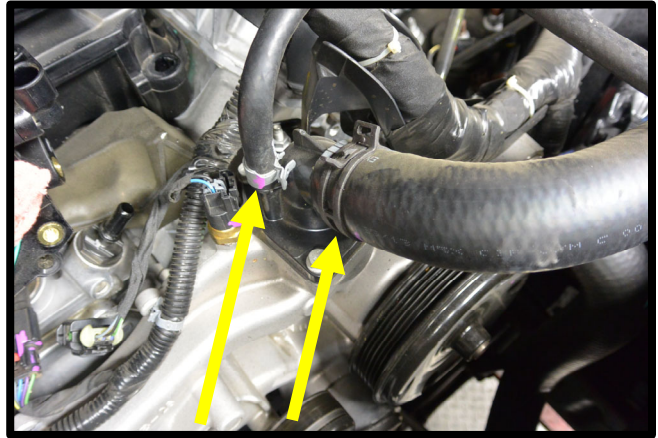
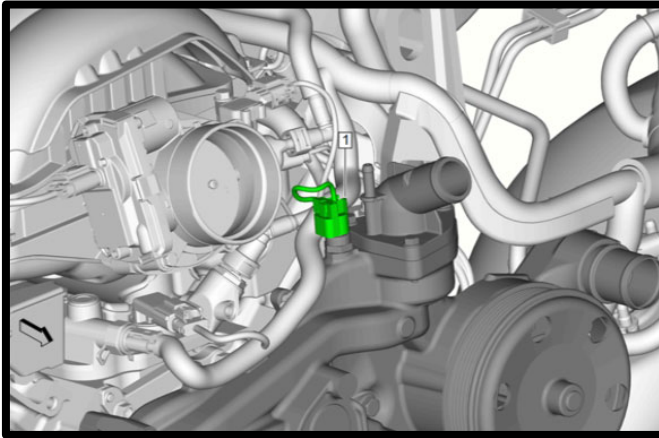

28. Using a 10mm socket, remove the thermostat housing from engine to ease SC installation. While off, clean oring and mounting surface. Cover with duct tape temporarily.

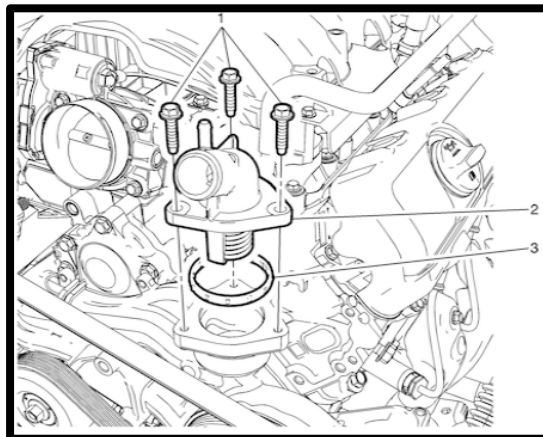

29. Remove the (2) bolts from the wiring harness support bracket. Use cutters and razor to remove zip tie and electric tape that secures harness to support bracket. Discard wiring harness bracket, this will not be reused.

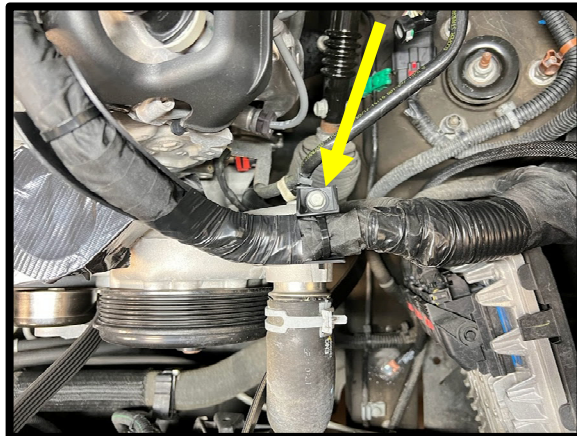

30. **(14-20 SUV ONLY)** Remove the two heater hoses from stock Tee fittings. Remove the center most tee fitting.

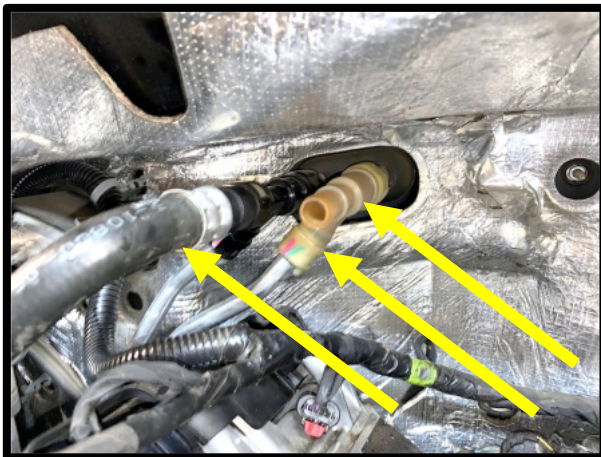

31. **(14-18 TRUCK ONLY)** Remove the two heater hoses from stock heater tube fittings for easier install. These will be reinstalled later in install.

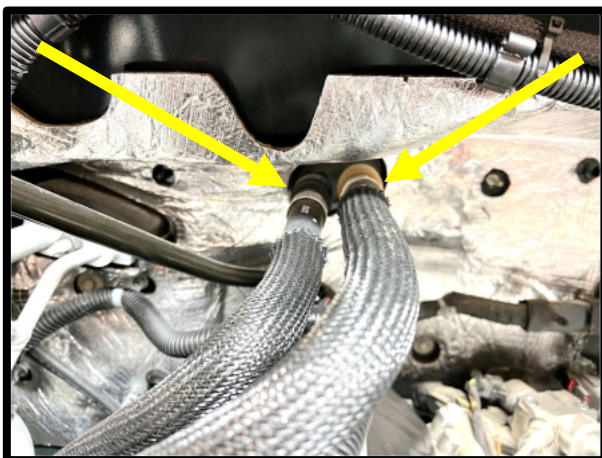

32. **(14-20 SUV ONLY)** Using a pipe over the heater tube, lightly bend towards RH (passenger side) of vehicle. For reference, the goal is to move the end of the fitting between 1/4" to 1/2" for clearance to the supercharger. This hose will be reinstalled later in install.

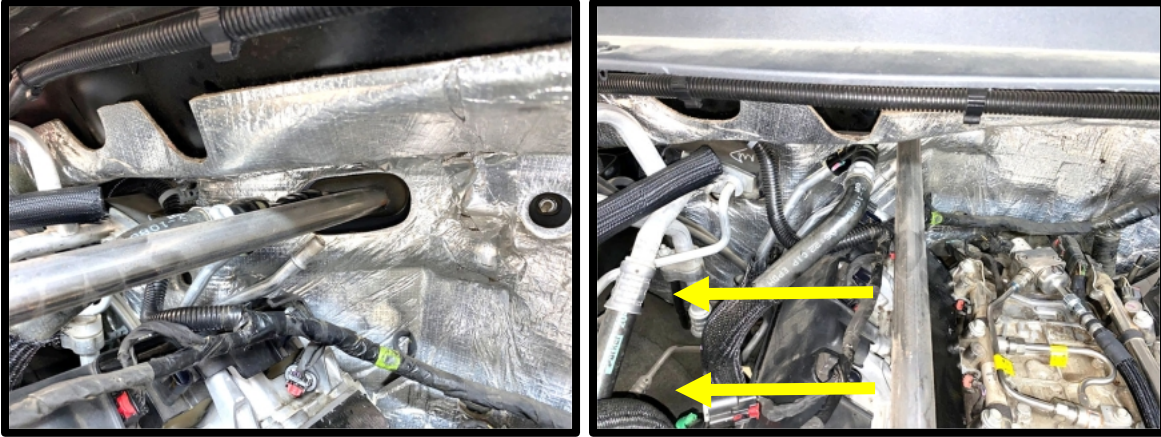

33. Install the supplied thermal sleeving over supplied fuel line.



34. Using a 10mm socket, loosen the center fastener, securing fuel line to valley tray.

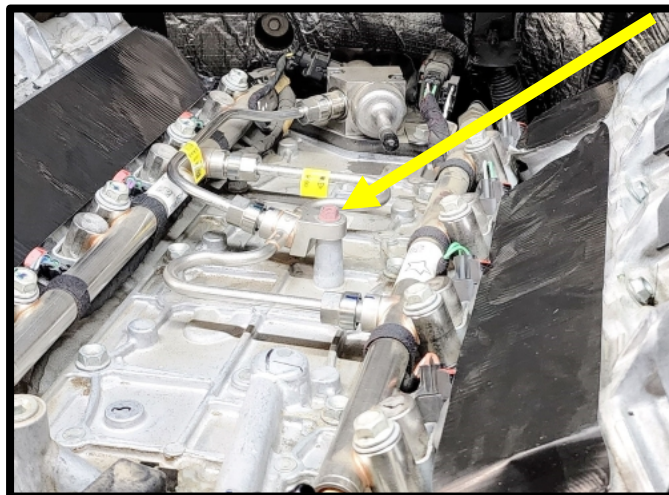

35. With the fuel rail fastener loosened, lightly lift up on the factory fuel tube route fuel line under factory fuel tube. Once line is routed, retorque factory bolt to 89 in-lbs. **CAUTION:** Never route OVER factory fuel tube.

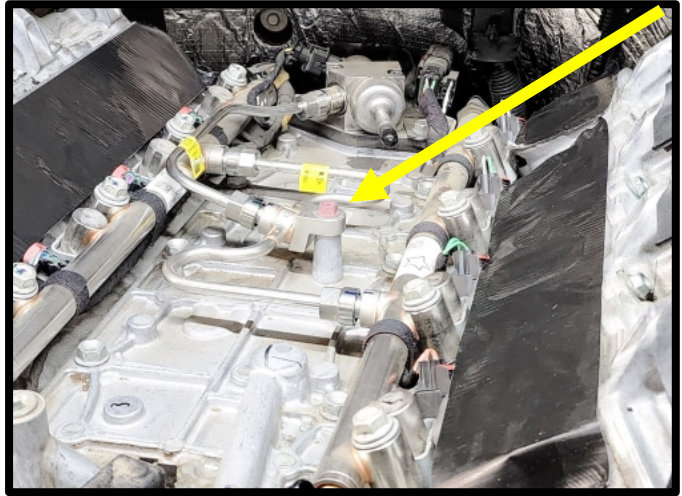
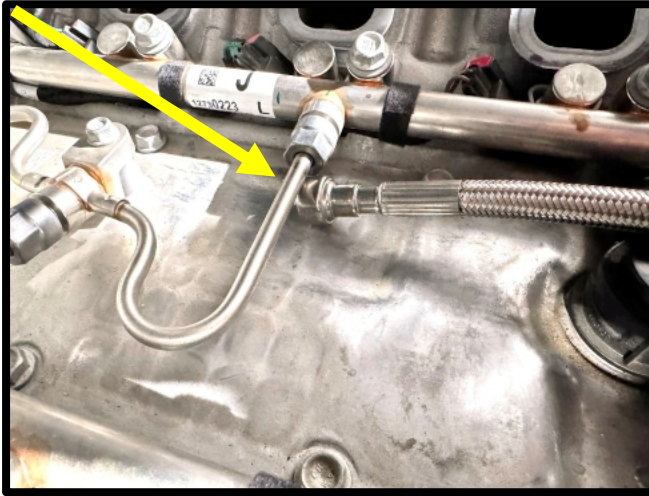

36. Install fuel line supplied to DI pump. Install the stock security lock on the fuel pump. Position to the bottom as shown in the image to properly clear the supercharger.

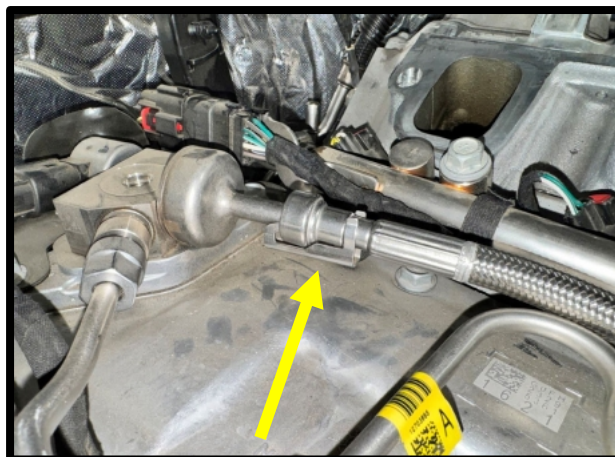

37. Route new feed line as shown, under the DI cross-over fuel line. Ensure that the line can't kink, bend or rub any sharp edges.

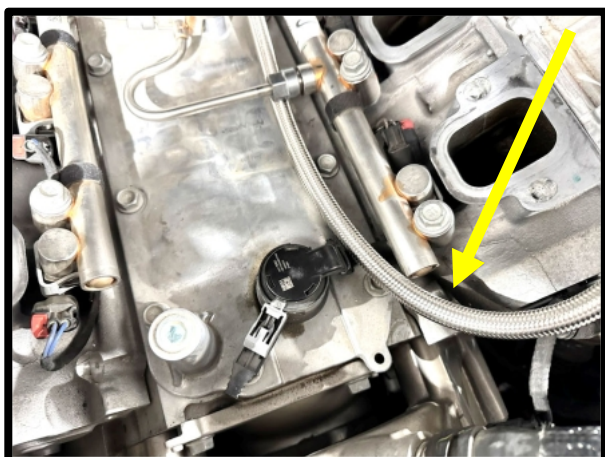
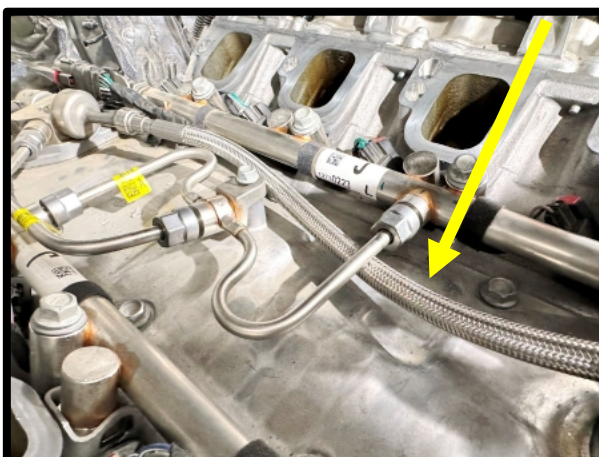

38. Apply light amount of grease to stock EVAP solenoid oring. Mount the stock EVAP solenoid to SC inlet using the stock EVAP bolt. Torque to 90 in-lbs.

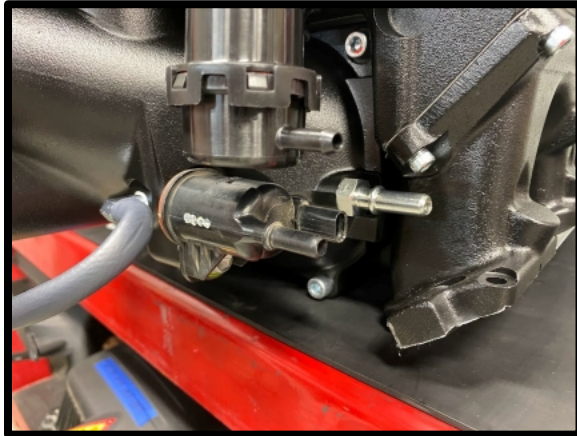
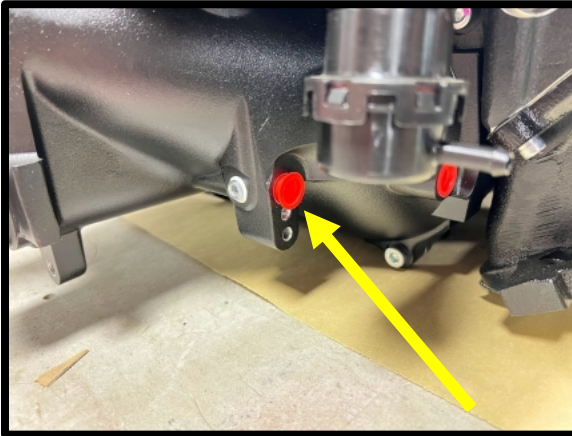

39. Install the (3) #2-906-V75BR orings to the (1) 9.89mm fitting and (2) -6 ORB plugs. Install the (1) 9.89mm fitting and (1) -6 ORB plug to the SC inlet RH side of inlet. Install the (1) -6 ORB plug to on LH side of inlet. Apply light amount of grease to oring to ease installation

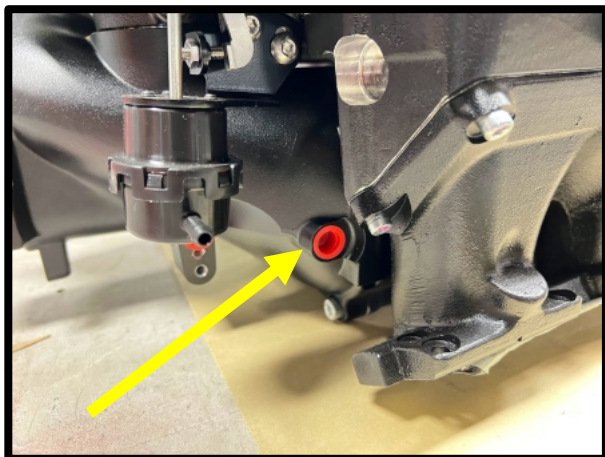
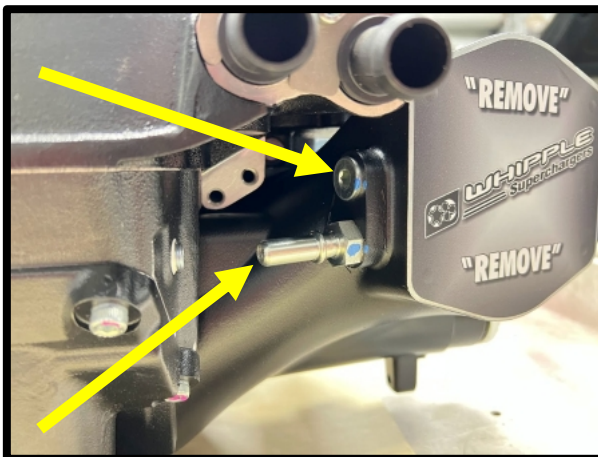

40. Install supplied bypass reference hose from bypass to SC inlet 1/4" barb fitting.

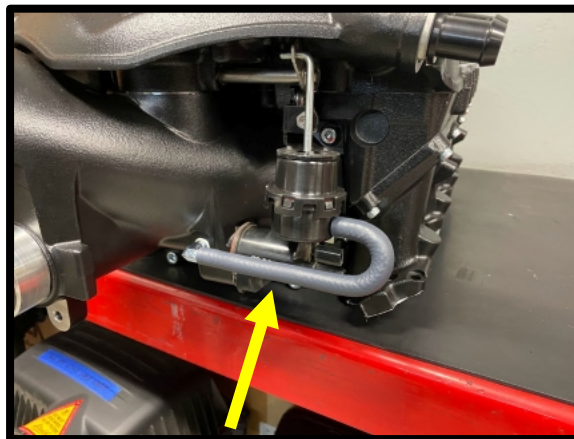

41. Install the supplied LT4 3-bar TMAP sensor (PN# 12644807) to the supercharger. Apply light amount of grease to oring before installing. Secure to manifold using the supplied 6mm x 20mm SHCS using a 5mm allen. Torque to 81 in-lbs.



42. Remove the factory orings from the intake manifold (8). Install these into the new intake manifold.

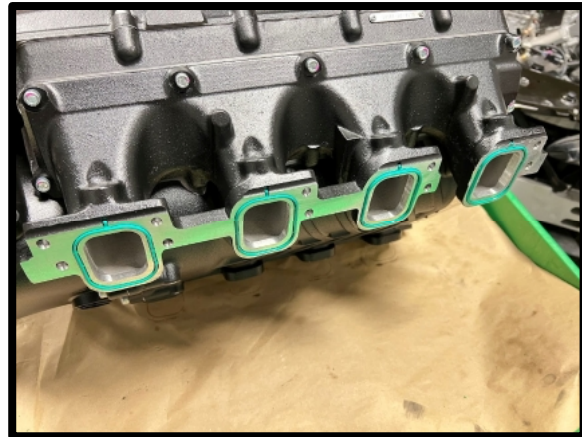
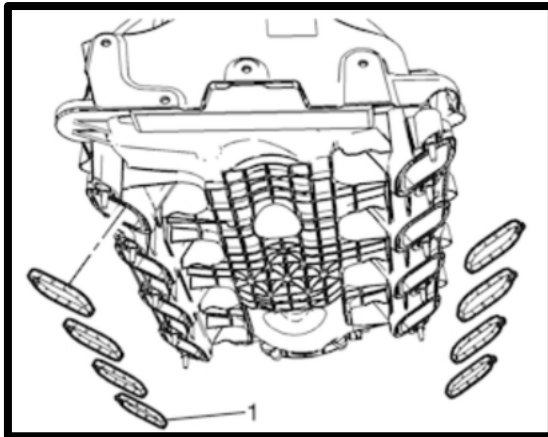

43. Make sure the supercharger is on a flat surface. Remove the oil fill plug using an 8mm allen socket.
- Fill the compressor to the **BOTTOM** of the fill plug (**4.0 FL/OZ**). Rock compressor back and forth. Then spin the compressor/rotors by the pulley so the oil fills the bearings. **NEVER OVER FILL THE SUPERCHARGER!**
  - Apply light amount of grease to oil fill plug oring, reinstall. Torque to 140 lbs-in.

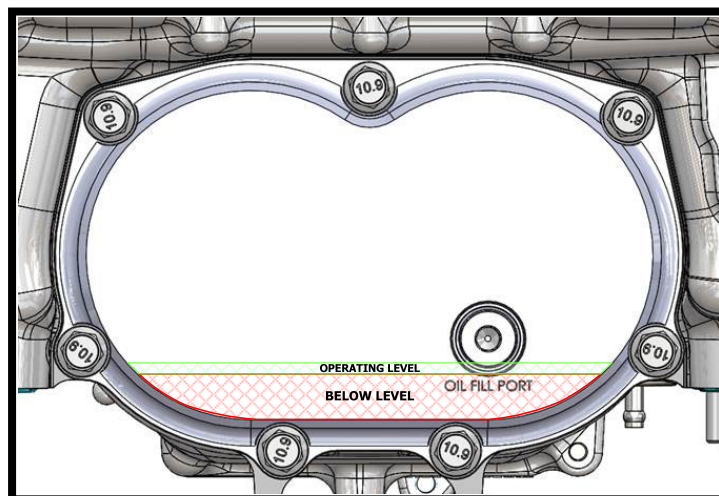

44. Install the supplied TMAP extension harness to the TMAP sensor before installing SC. Press until it clicks in place.  
**NOTE: This extension could fit backwards when connecting to stock MAP connector, ensure that the color wires and pin locations match! (Pin 1= Gray, Pin 2=Black, Pin 3=Green).**

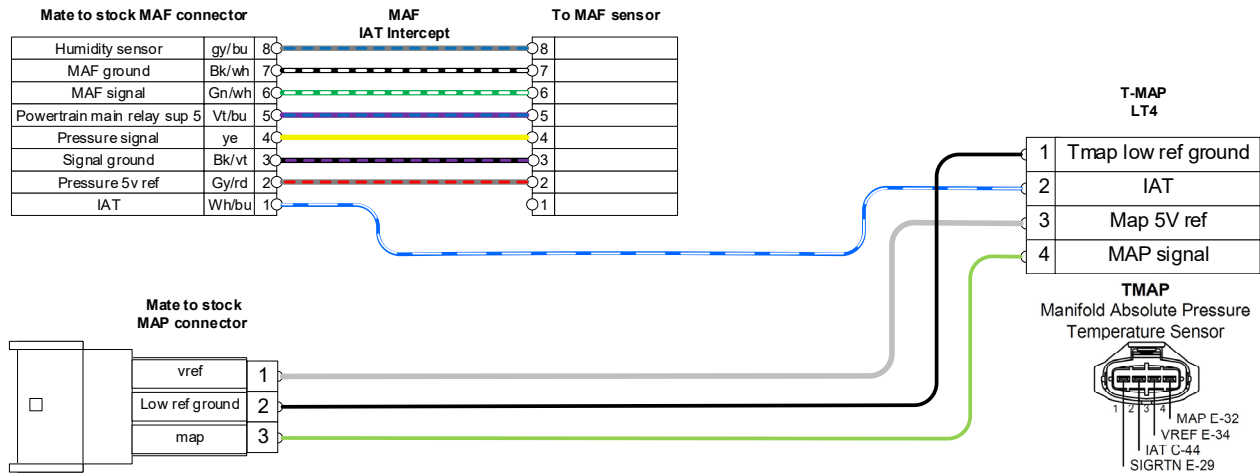

45. Remove the (3) factory fasteners using a 13mm socket on driver side and 15mm socket on passenger side.

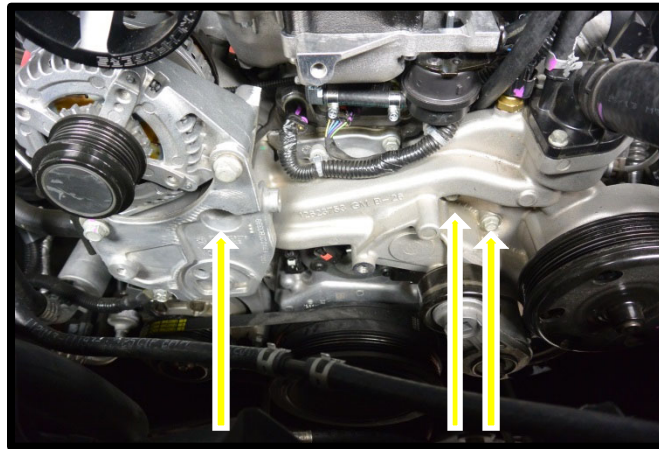

46. Remove the tape you previously installed on the intake manifold. Clean the cylinder head surface in preparation for supercharger installation.



47. Install the supercharger assembly to the engine. You'll have to slide the last few inches as firewall clearance is minimal. Pay close attention to the orings, ensure they don't fall out or move. Do not tighten or secure at this time (must do after belt system is installed). NOTE: Be careful of PCV valve during installation.

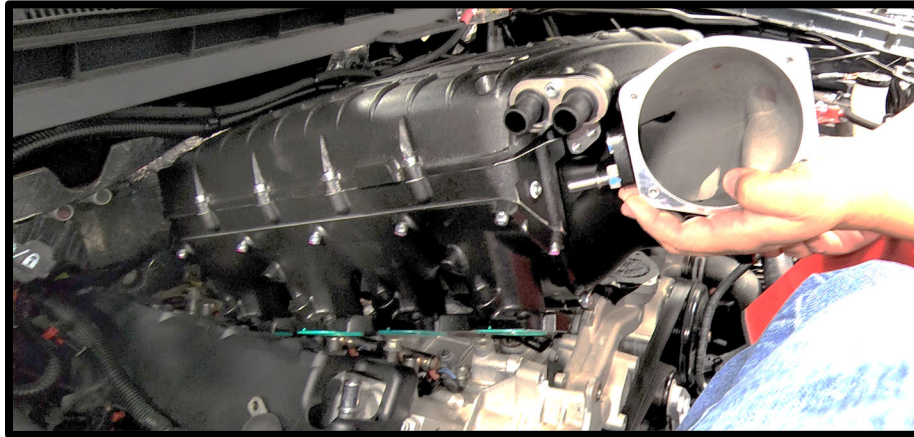

48. Apply light amount of  **Loctite #242** to the (10) 6mm x 30mm HHFCS bolts. Install bolts to runners, using 10mm socket. Hand tighten at this time. \*NOTE: Use a 1/4" socket and drive set for installation, failure to do so will potentially cause interference with a 3/8" type socket and counter bore. \*\*These will be torqued in a later step.

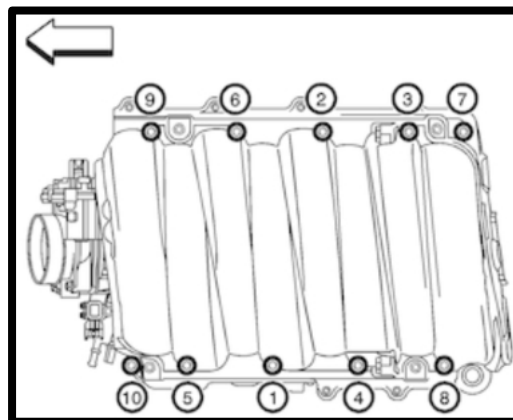

49. Install the front idler plate to the engine by using the supplied (3) spacers and the idler plate. Install the (1) 8mm x 22mm SHCS into top bolt, securing plate to SC. Install the (2) 44.32mm spacers on the driver side with the (2) 8mm x 130mm SHCS. Install the (1) 10mm x 150mm SHCS bolt to secure plate to alternator bracket, use the (1) 21.15mm spacer on back side. Once you get the (4) bolts started, torque the 8mm SHCS to 15 ft-lbs and the 10mm SHCS to 28 ft-lbs.  **Loctite™ #242 all (4) bolts.**

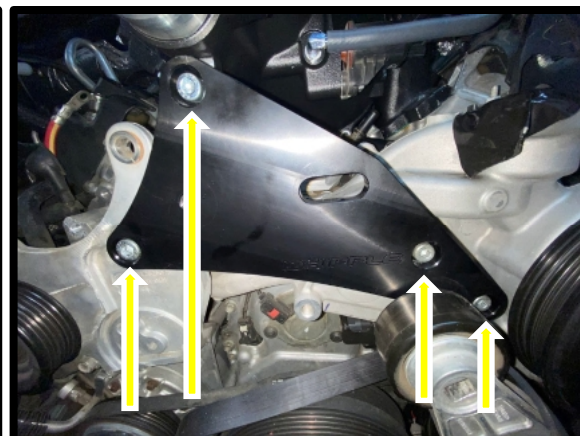
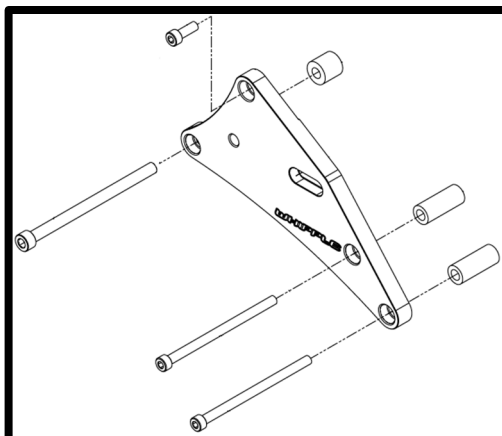

50. Secure supercharger to cylinder heads using the supplied (10) 6mm x 30mm HHFCS. Torque to 44 in-lbs on first pass, follow with a final torque to 89 in/lbs. **\*NOTE:** Use a 1/4" socket and drive set for installation, failure to do so will potentially cause interference with a 3/8" type socket and counter bore.

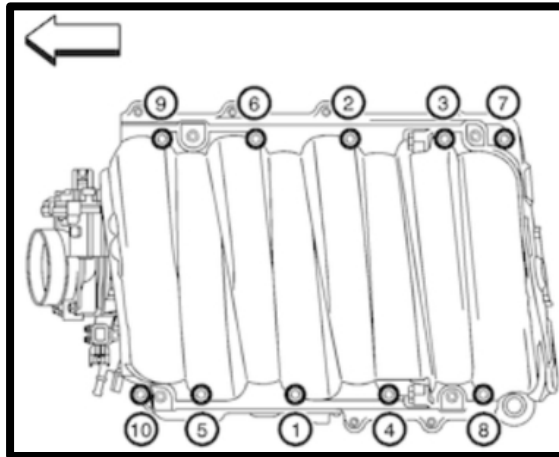

51. Install the sliding tee-nut to the slotted hole on the front plate (from the back side). Face the shortest end towards the center to allow maximum idler adjustment. Utilize the supplied step spacer with the 1/2" ID hole to the backside of the smooth idler pulley. Use the supplied 1/2" ID step washer on the front of the idler. Use the supplied 1/2" x 1 3/4" SHCS to secure idler to sliding tee-nut and idler plate. Leave slightly loose for now.

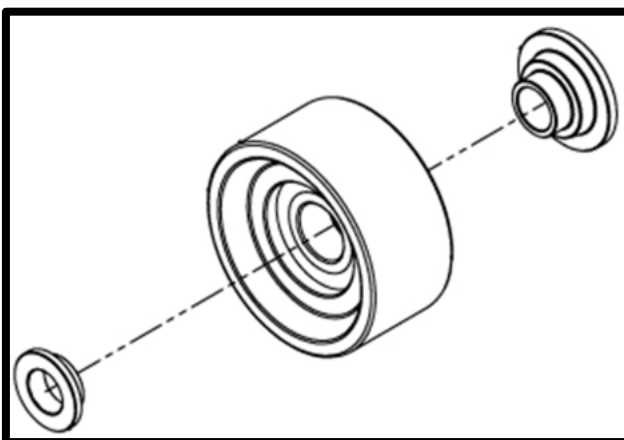
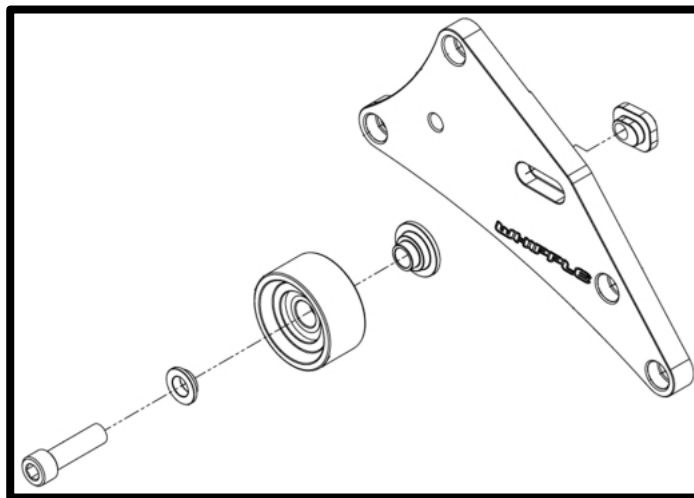

52. Install the supplied grooved idler pulley to the factory tapped hole below the alternator. Use the supplied step spacer with the 10mm ID hole and the 10mm ID step washer on the front of the pulley. Use the supplied 10mm x 35mm SHCS to secure pulley to factory bracket (8mm allen socket), use light amount of anti-seize. Torque to 28 ft-lbs.



53. Reinstall alternator in stock location, using factory hardware. Torque to 25 ft-lbs. Connect the alternator 2-way connector and power wire. Reinstall AC line support bracket when applicable.

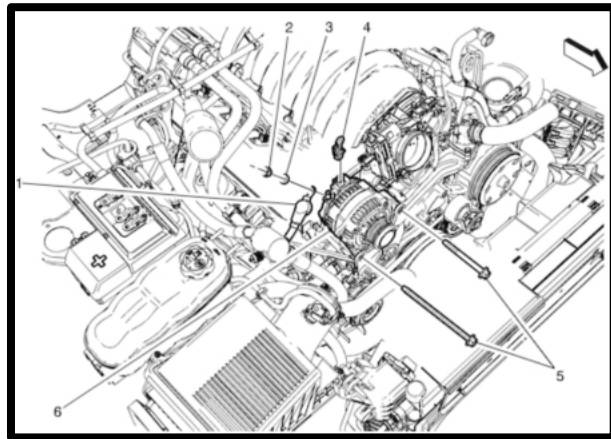

54. Install the supplied smooth idler pulley to the new idler plate below the alternator. Use the supplied step spacer with the 1/2" ID hole and the 1/2" ID step washer on the front of the pulley. Use the supplied 1/2" x 1 1/2" SHCS to secure pulley to idler plate (8mm allen socket) use light amount of anti-seize. Torque to 28 ft/lbs.



55. Install the supplied supercharger pulley using the supplied (5) 6mm x 14mm SHCS to secure. Torque to 119 in-lbs using a 5mm allen socket. Use the 6-rib belt to hold the pulley in place to torque. **NOTE:** Loctite or thread locker is not required or needed.

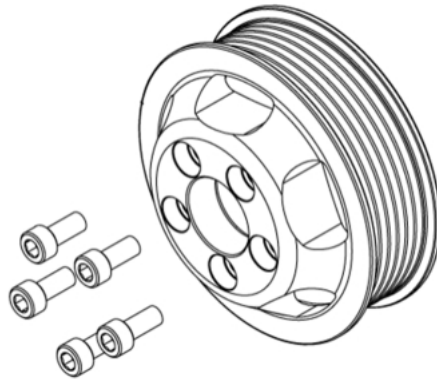

56. Mount the spring-loaded tensioner back into its stock location and torque to 18 ft-lbs. using a 15mm socket. Note: This should be between 75% to 90% max open for maximum travel during belt stretch. Using a 1/2" breaker bar, release all the tension from the spring-loaded tensioner. Using a 3/8" allen socket and your hand, push the sliding idler as far as you can down to take all extra belt slack away. Lock the 1/2" SHCS bolt with the 3/8" allen socket (torque to 32 ft-lbs) and release the spring-loaded tensioner. **NOTE:** Leaving belt loose will result in belt coming off during WOT operation, always remove slack from belt system.

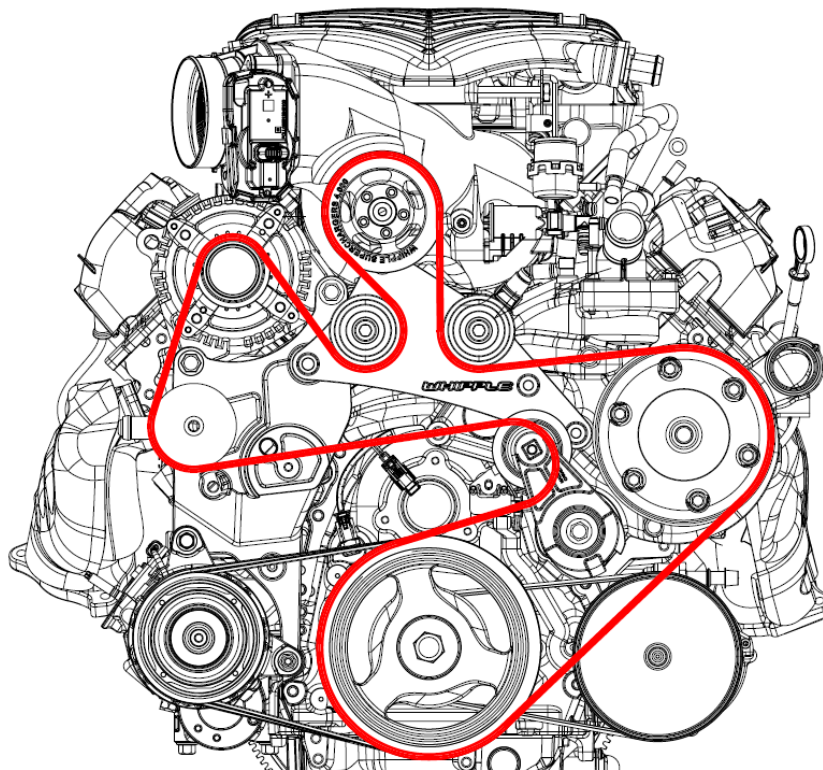

57. Install the supplied fuel block to factory fuel feed hose position, using factory fastener. Torque to 106 in-lbs.



58. Install the (2) 9.49mm to -6 ORB fittings with (1) #2-906-V75BR oring per fitting to the fuel block.

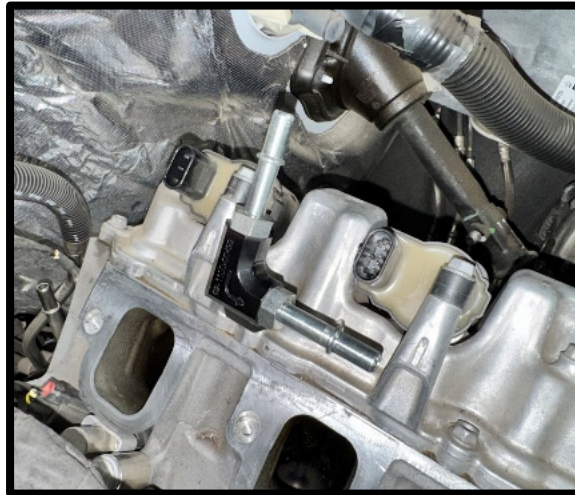

59. Connect factory feed line to top 9.49mm fitting, apply pressure until it clicks and locks in place.

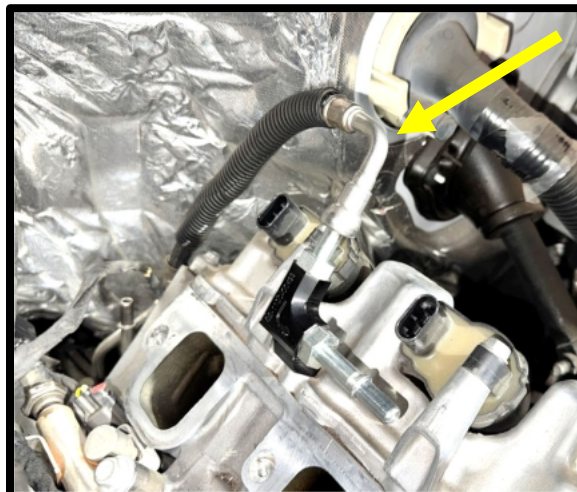

60. Connect the previously installed fuel line to forward facing 9.49mm fitting. Apply pressure until it clicks and locks in place. NOTE: Shown without SC for example.

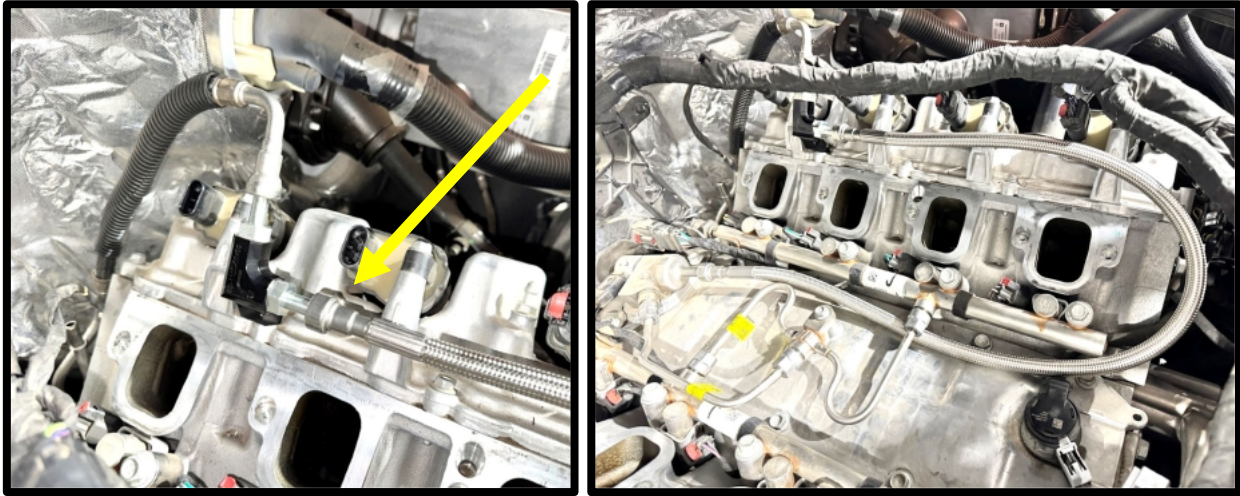

61. Secure the stock wiring harness to the water pump, using the supplied adel clamp and supplied 6mm x 15mm HHFCS.



62. Install the supplied 3/8" ID PCV hose #3103248 with the dual 90deg 9.89mm fittings to the valley tray quick connect fitting (straight end). Route the hose and the 90deg up towards driver side. Connect 90deg fitting to driver's side rear fitting on inlet of SC. Push until it clicks and locks in place.

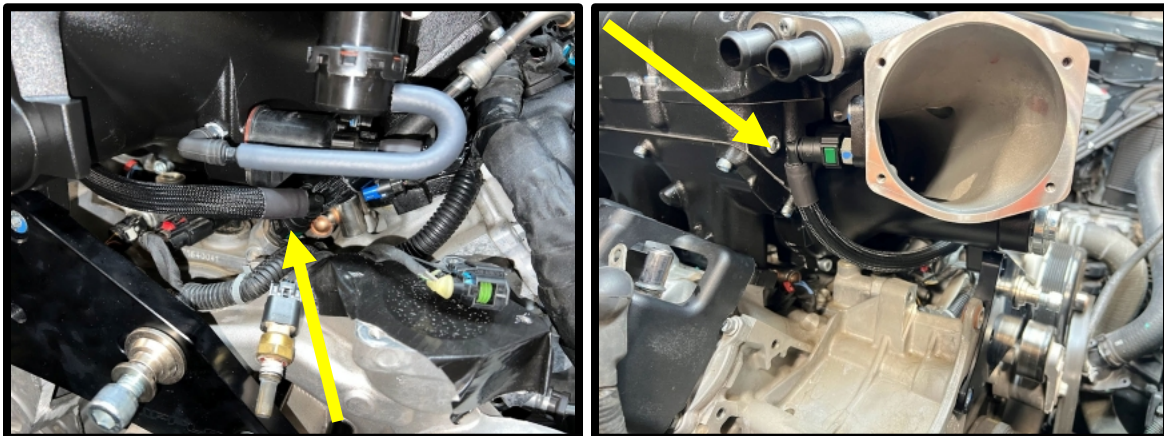

63. Connect the supplied pre-formed EVAP hose #3103252 with the dual 7.89mm fittings from the EVAP solenoid previously installed to SC, then to factory connection near firewall.

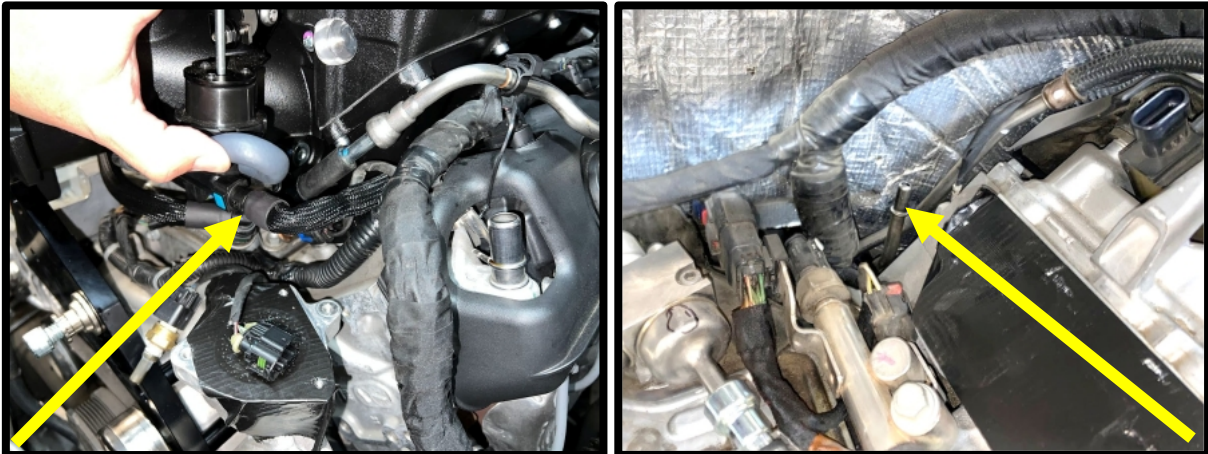

64. Install the supplied preformed IC inlet hose #3103144 to the LH rear fitting. Route around the back of the SC to RH side of engine. Install supplied Y fitting to end of this hose. Install supplied hose #3103145 to RH side, rear IC inlet fitting. Route other end to the Y fitting. Secure hose to the IC inlet fittings with supplied black 16mm-27mm black worm clamps. Secure other ends with supplied #16 pinch clamps. **NOTE: DO NOT MIX UP!**

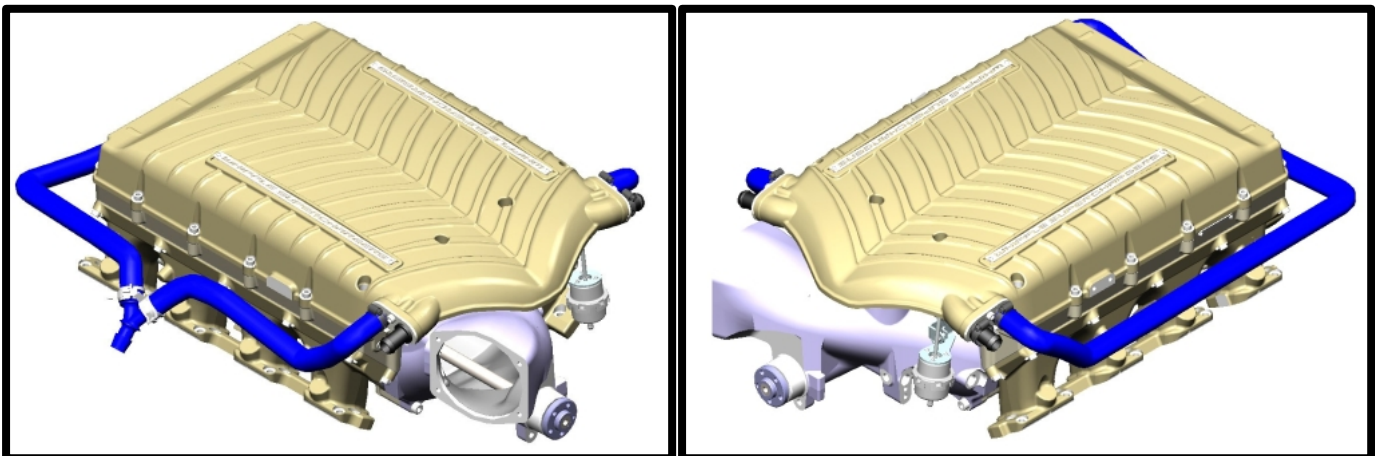

65. Install the supplied preformed IC outlet hose #3103144 to the LH front fitting. Route around the back of the SC to RH side of engine. Install supplied Y fitting to end of this hose. Install supplied hose #3103145 to RH side, front IC inlet fitting. Route other end to the Y fitting. Secure hose to the IC inlet fittings with supplied black 16mm-27mm black worm clamps. Secure other ends with supplied #16 pinch clamps. **NOTE: DO NOT MIX UP!**

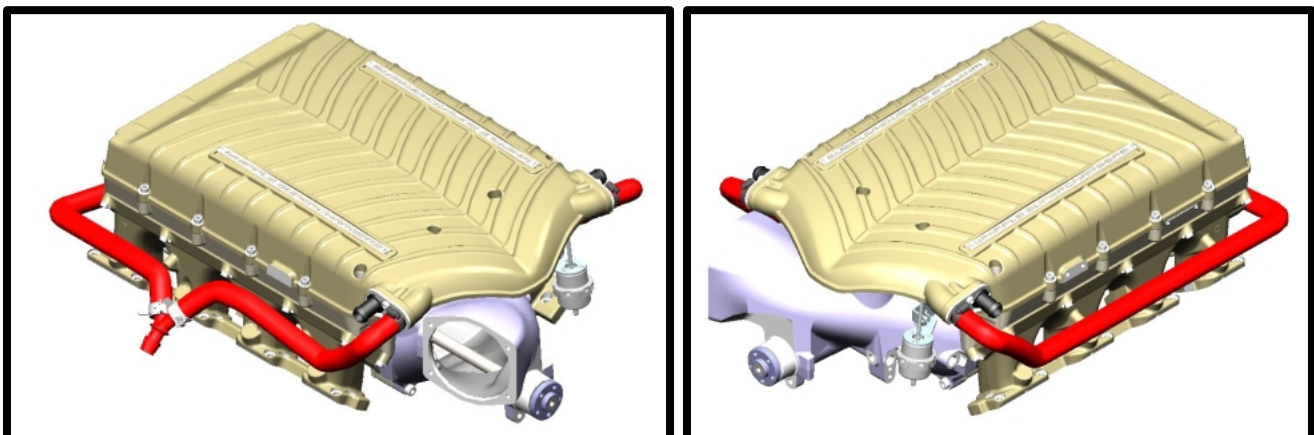

66. Pre-route the LH valve cover make up air hose from the LH valve cover, under the SC inlet, behind the alternator for later installation to the air inlet tube.



67. Reinstall stock coolant temperature sensor to factory location. Reinstall stock thermostat housing with stock oring and stock fasteners. Torque to 89 in-lbs. Reinstall degas bottle vent line to thermostat housing using stock clamp. Reinstall thermostat housing outlet hose to thermostat housing using stock clamp.

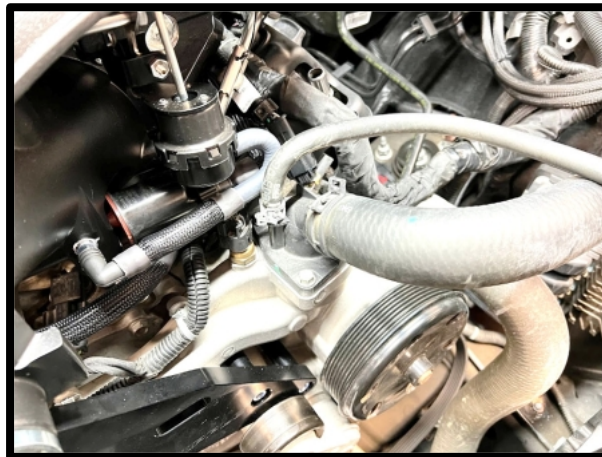

68. Install the IC filler reservoir bracket to the RH front fender support brace. Remove the stock bolt using a 13mm socket. Secure bracket using supplied 8mm x 18mm HHFCS, torque to 18 ft-lbs.



69. Install the IC filler reservoir to the bracket using the supplied (2) 6mm x 14mm HHFCS (10mm socket). **NOTE:** 3/8" barb should face forward.



70. Remove the factory top plastic radiator shroud by removing the factory plastic pins with a panel puller.

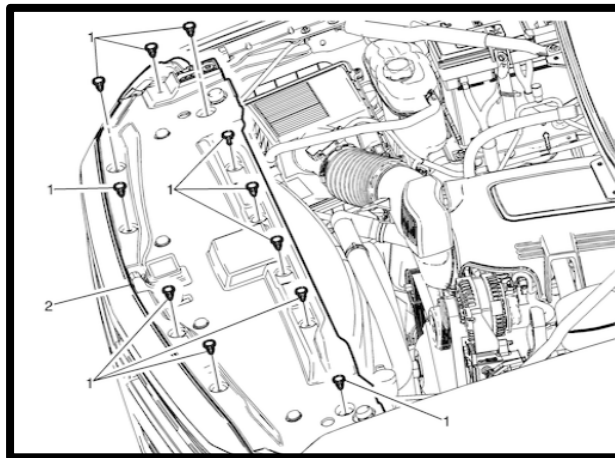

71. When applicable, use a 7mm socket and Torx T15 to remove the front two bolts of the fender guards. Carefully disengage the fender guards by dislodging the front plastic retaining clips. **NOTE:** Only front needs to be removed for later grille removal.

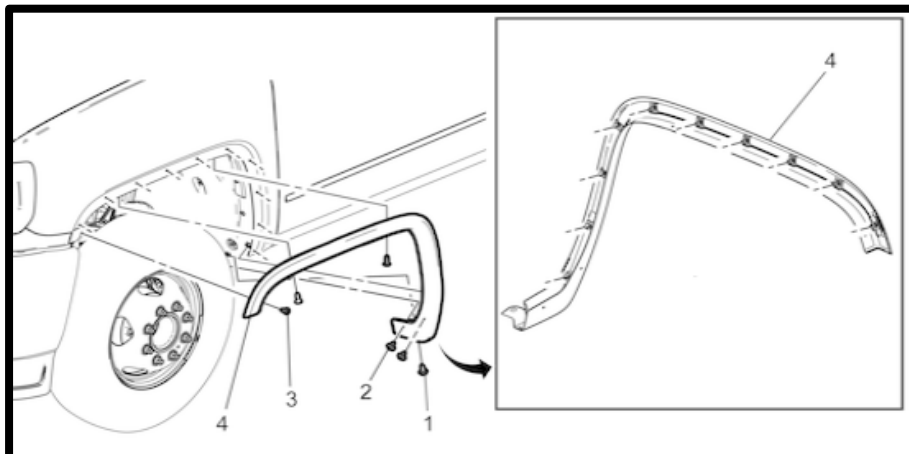

72. Using a 7mm socket, remove the (4) bolts (2 per side) securing the fascia assembly. NOTE: Lining doesn't have to be fully removed, this just helps ease installation.

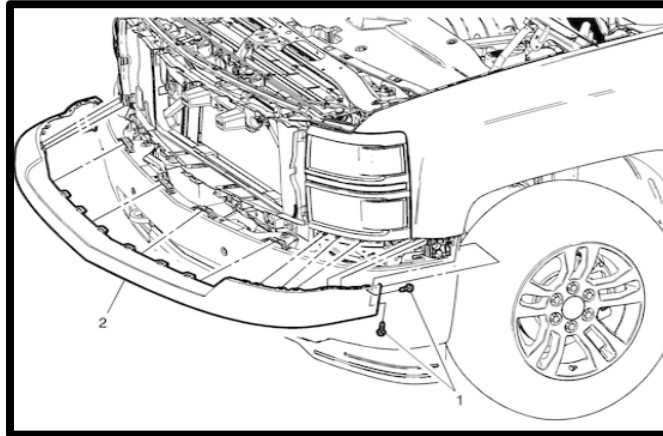

73. Remove the front grille from vehicle (grille mounting may vary by year and model) by removing the (4) top bolts, then starting at either end, pull firmly on the front grille releasing the (8) spring clips.

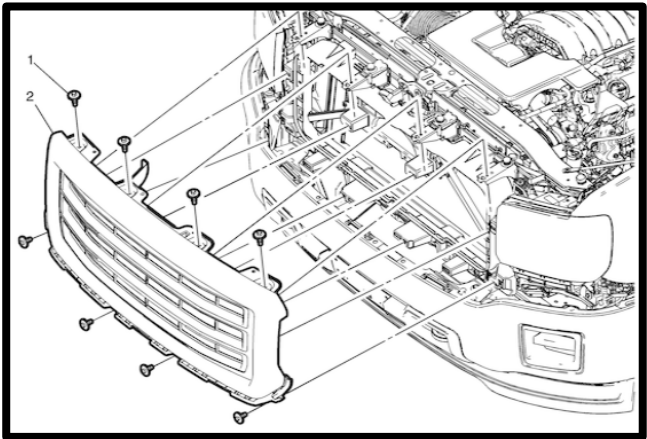
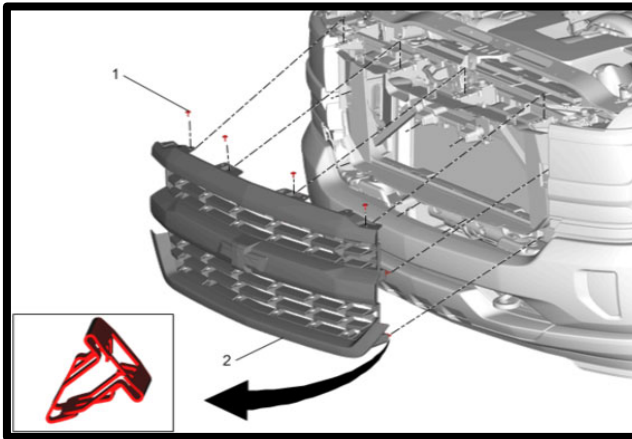

74. **(One Piece Fascia)** Remove the (8) bolts from top of fascia. Remove the (2) in inner fender area. Remove the (4) from the lower section of fascia. Carefully push a small nylon wedge between the fascia and the front fascia guide. Insert a small flat-bladed tool into the fascia slot and depress the snaps one at a time and pull on the fascia at the same time to gradually remove the fascia from the front fascia guide. Release the front center grille support tabs using appropriate tool from beneath the vehicle with assistance. Disconnect electrical connectors before attempting to remove. Remove fascia from vehicle with assistance.

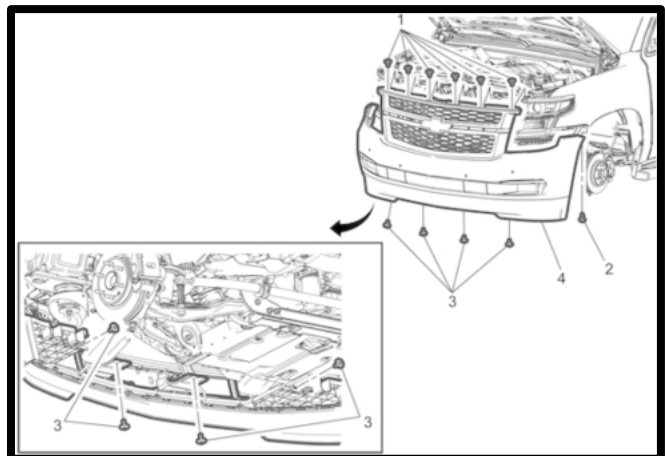
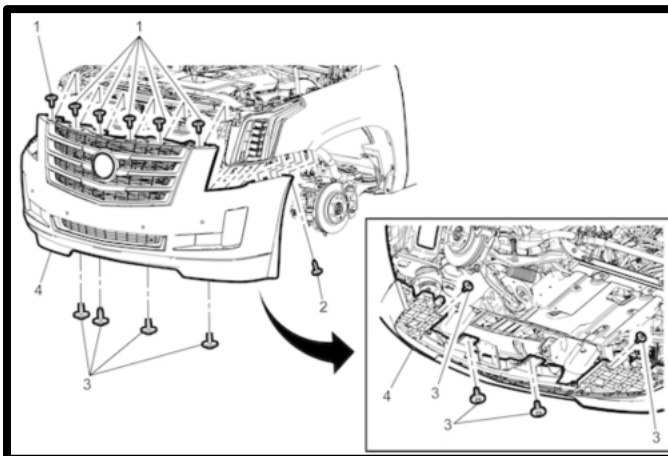

75. Remove both LH and RH head lights (4 bolts per). Disconnect electrical connectors once headlight is pulled away from vehicle.

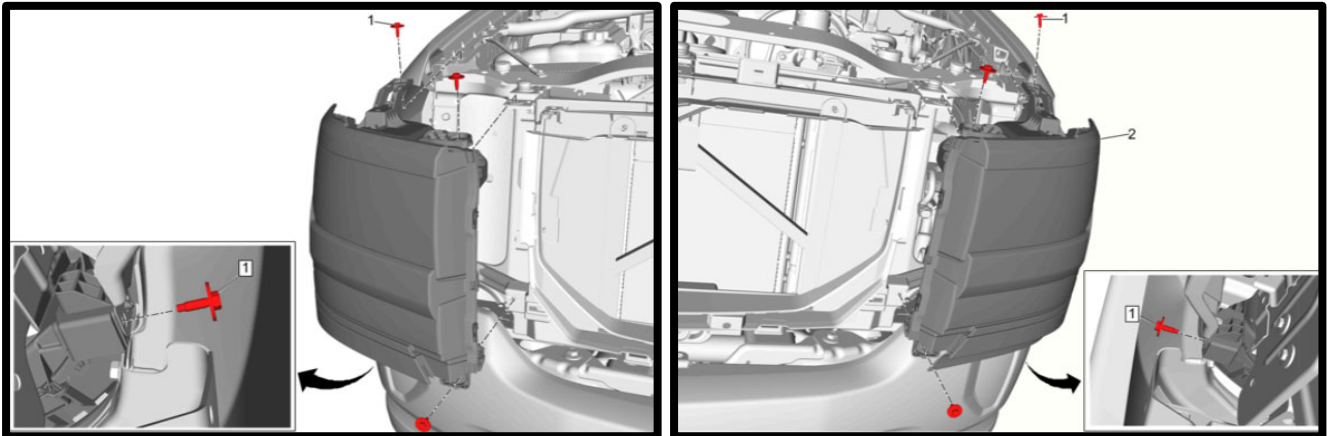

76. **(2016 and up with air shutters)** Remove the air shutters to install the LTR. Disconnect shutter connector and remove the (9) bolts securing to vehicle. This will be put back in the stock location once the LTR is installed.

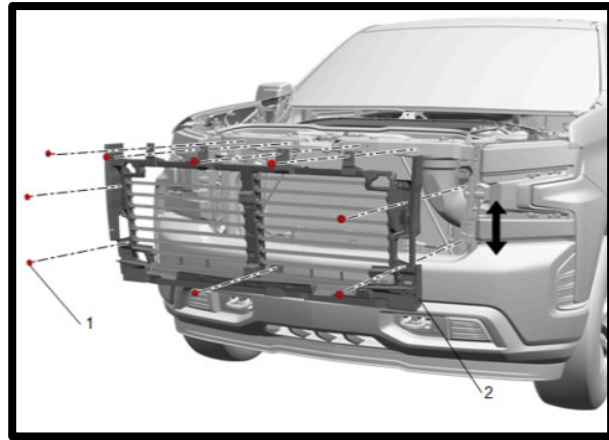
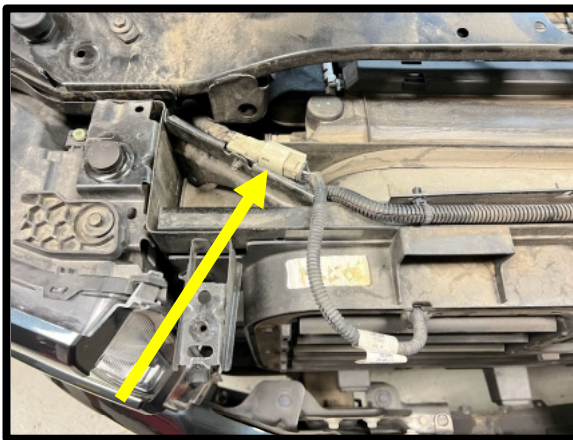

77. Unplug the ambient air temp sensor and hood sensor connectors. Using a 13mm socket, remove the (2) bolts securing the hood assembly. Remove the hood latch assembly and move aside.

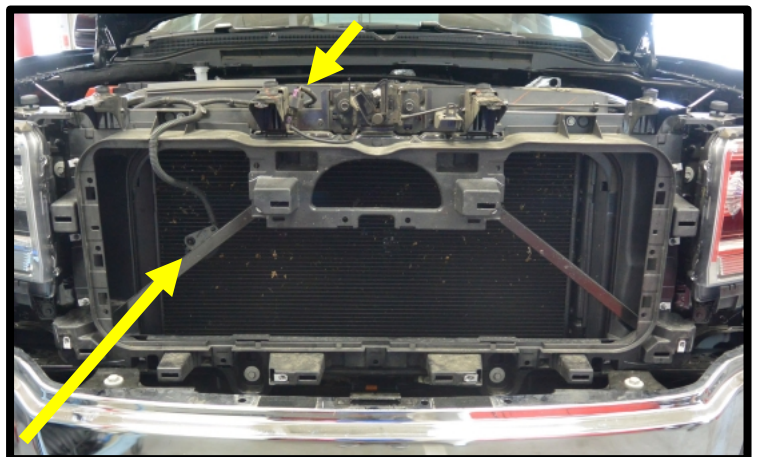
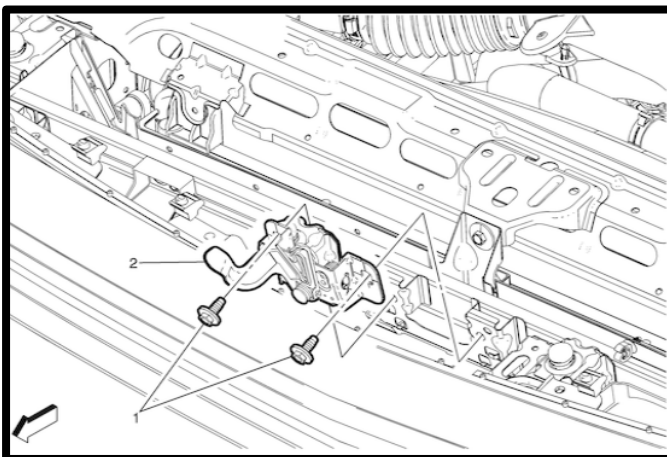

78. Remove the headlight and grille mount bracket from vehicle by removing the (13) bolts.

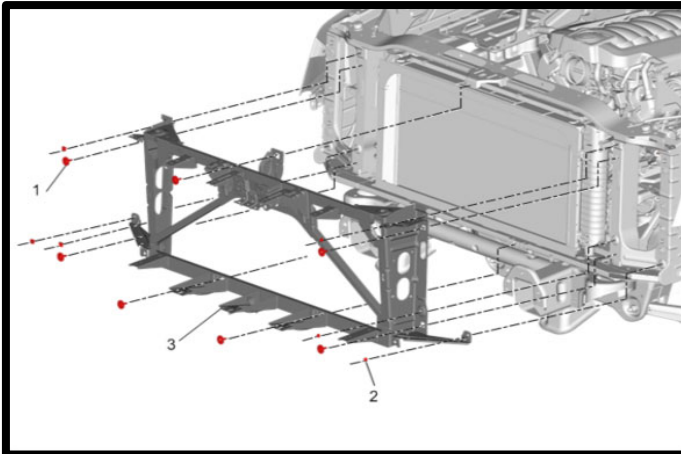

79. With the vehicle on a lift or jack stands, locate the (2) front frame support bolts (RH side of frame rail). Using a socket, loosen the 2 bolts. Install IC pump bracket over and behind stock bolts. Retorque to 22 ft-lbs.

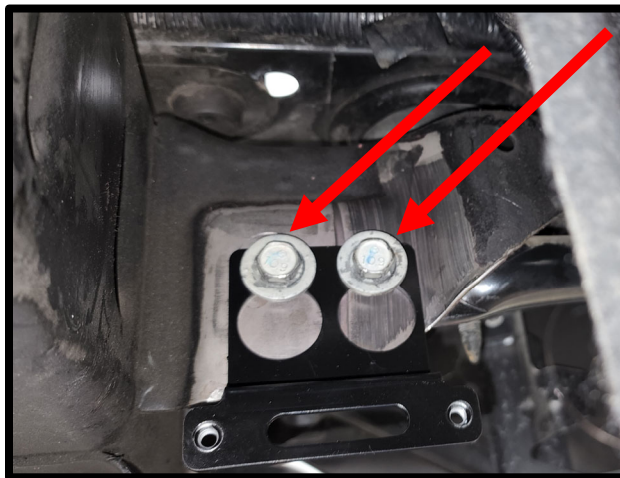
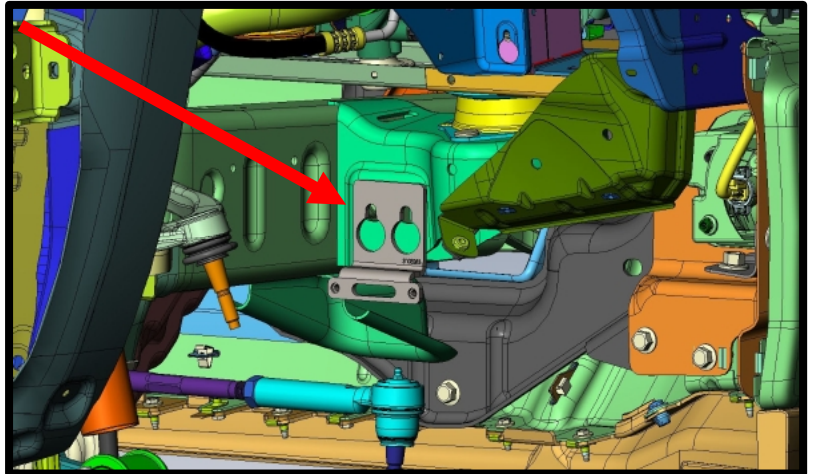

80. Install the supplied intercooler electric water pump to the supplied T-bolt clamp. Install pump and T-bolt clamp to supplied bracket using the (2) 6mm x 10mm HHFCS. NOTE: Cover open ports of IC pump to ensure debris can't contaminate pump.

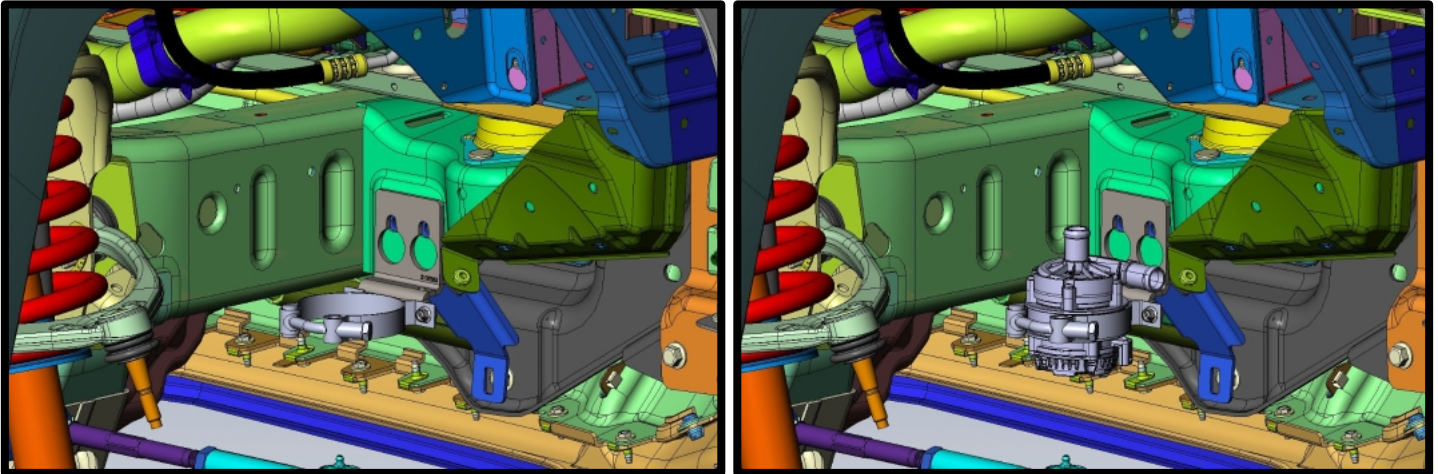

81. **(Truck Only)** Remove the (4) stock bolts from the backside of the headlight/grille bracket. Mount the LTR brackets to the stock bolt locations, secure with stock bolts. Torque to 80 in-lbs.

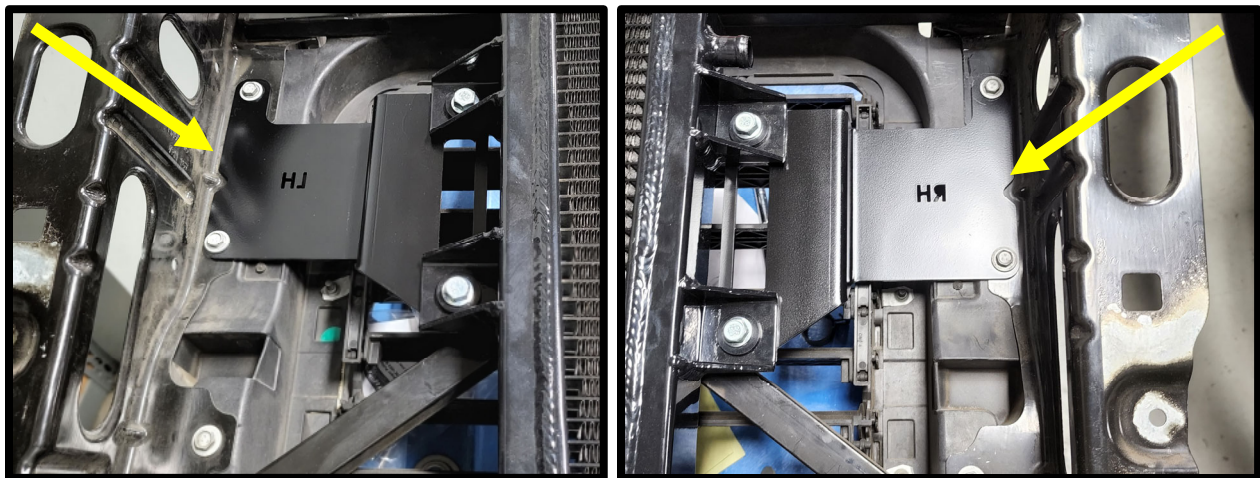

82. **(SUV Only)** Mount the LTR brackets to the backside of the headlight/grille bracket. From the front side, secure the LTR brackets using the supplied (4) 8mm x 14mm HHFCS. Torque to 80 in-lbs.



83. Mount the LTR to the brackets using the supplied (4) 8mm x 16mm FHSCS and (4) .813" sleeved washers. Torque to 16 ft-lbs. **NOTE:** Images show from the back of the LTR.

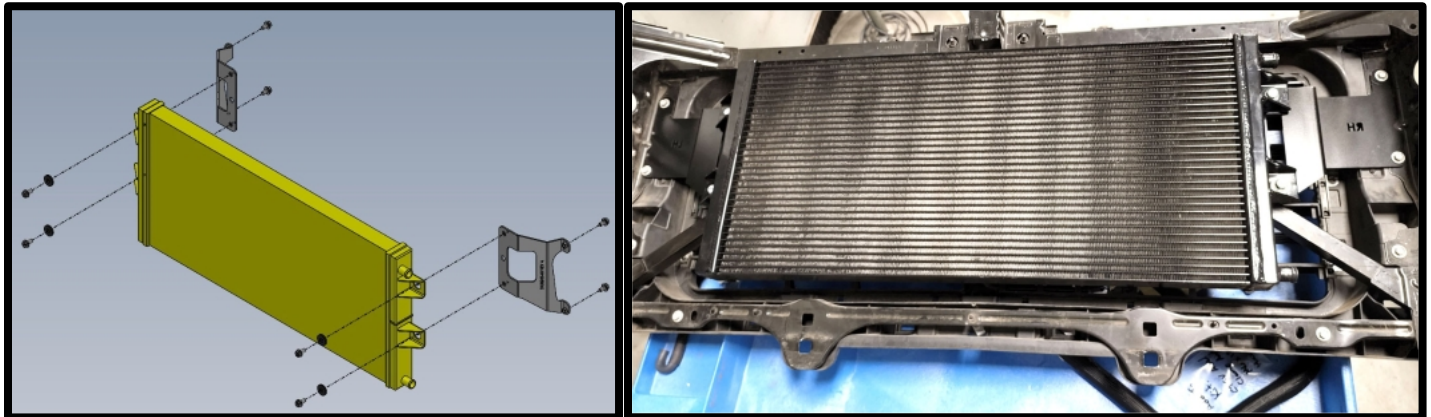

84. (**TRUCK**) Mock up the plastic radiator closeout. For top fitting, cut approximately a 2" square for hose clearance. For the bottom fitting, cut a 3" x 4" section away for hose clearance.

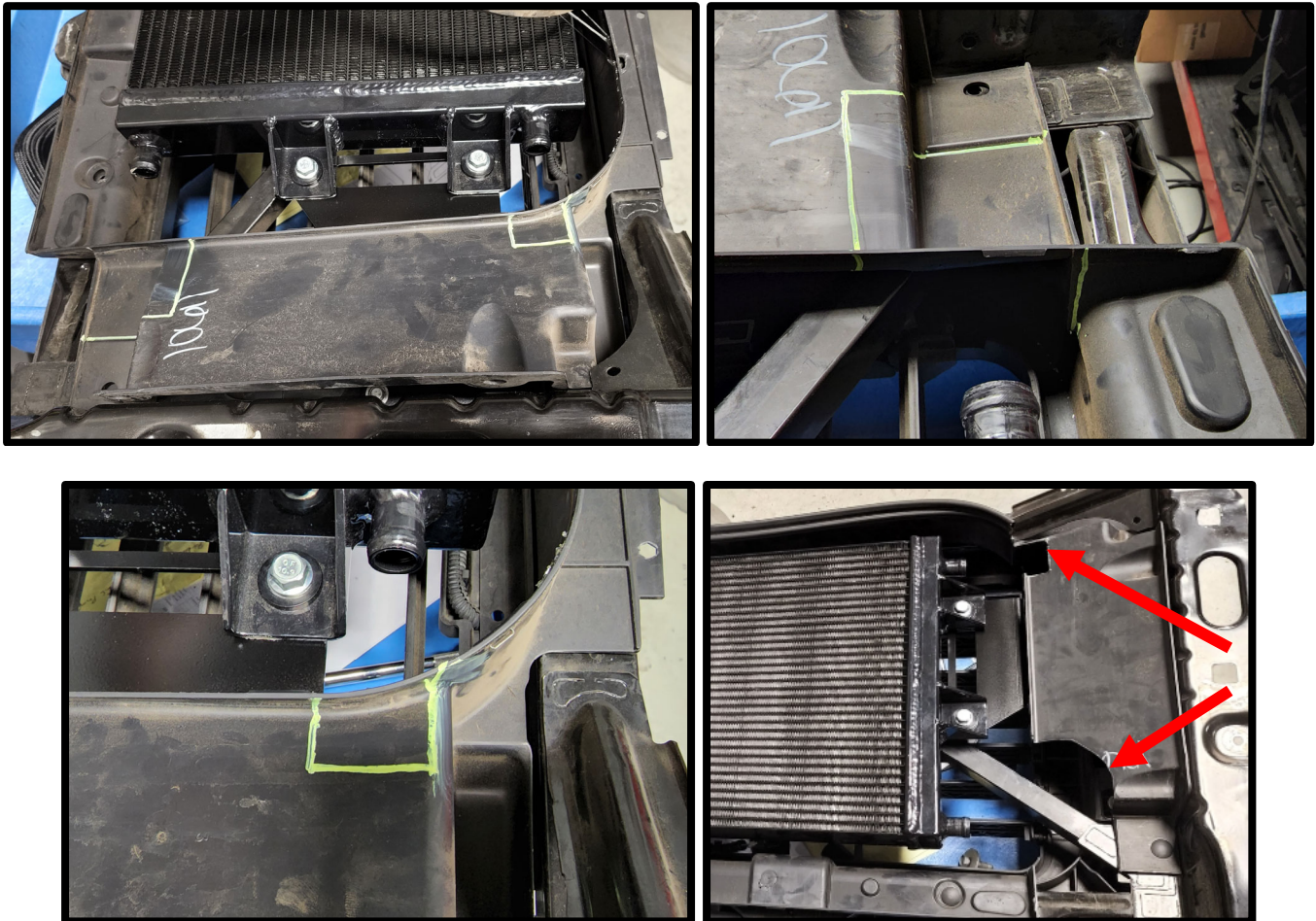

85. Pre-route the supplied IC to LTR hose. Install #3103255 to the bottom fitting. Secure with supplied pinch clamp.

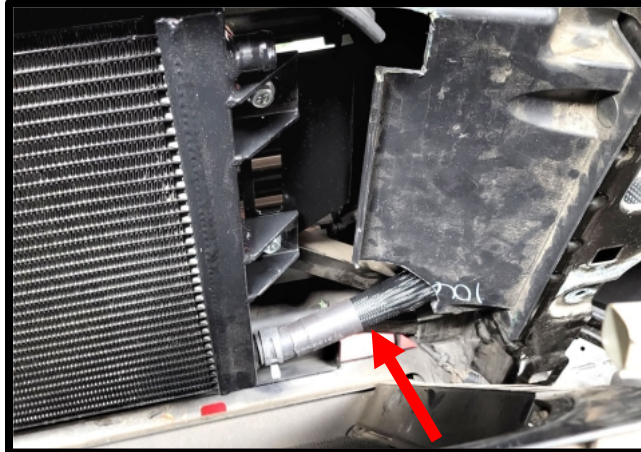

86. Route the LTR to IC feed hose #3103256 through the headlight weather shield (some require small X notch for hose).

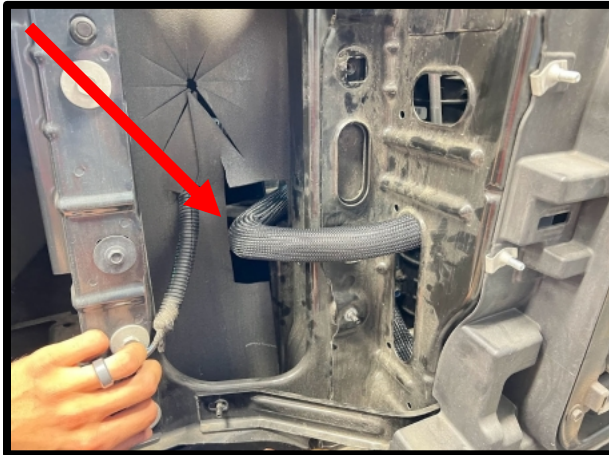

87. Loosely mount the LTR and headlight/grille bracket assembly back to vehicle using the factory hardware. Route the LTR to IC feed hose #3103256 to the top fitting. Secure with supplied pinch clamp.

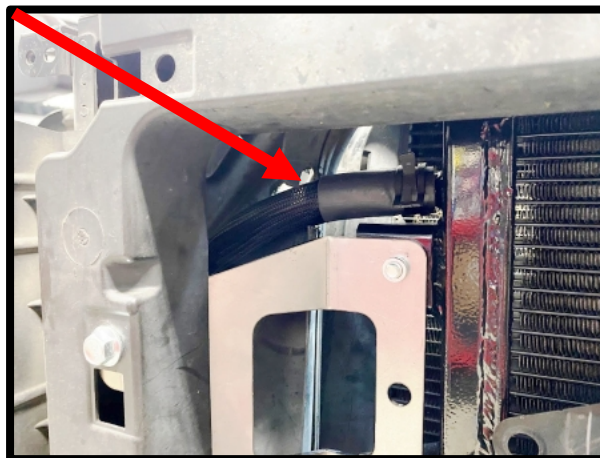

88. Install the supplied shielding around stock opening, cut to fit. **NOTE:** This shape varies vehicle to vehicle.



89. Secure the headlight and grille mount bracket back to factory location. Torque (1) 18 ft-lb, (2) 80 in-lbs.

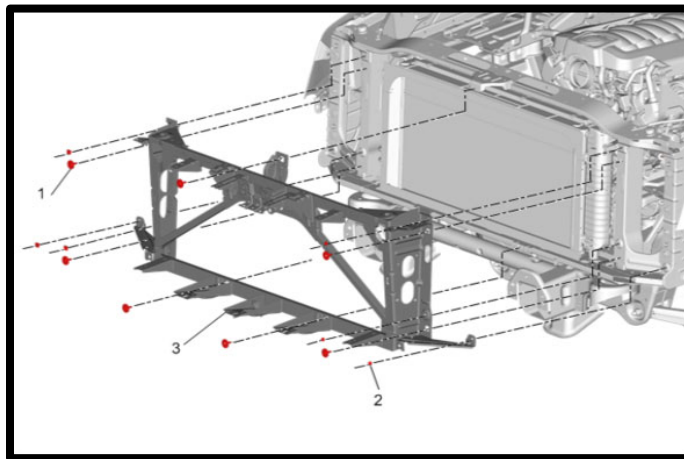

90. **(2016 and up with air shutters)** Reinstall the air shutters. Torque to 53 in-lbs. Reconnect shutter and ambient air temp sensor electrical connections.

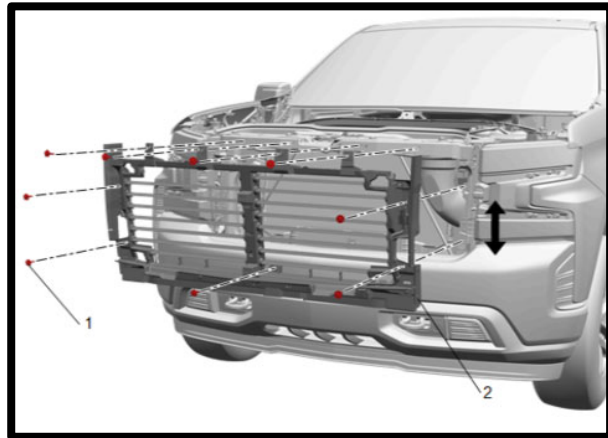
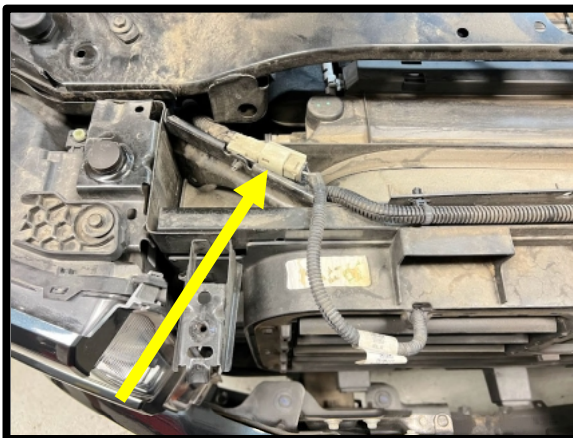

91. Install the preformed hose #3103255 from the IC pump outlet to the LTR feed fitting (lower fitting). Secure with supplied pinch clamps. **NOTE: DO NOT LET THIS HOSE KINK!!**

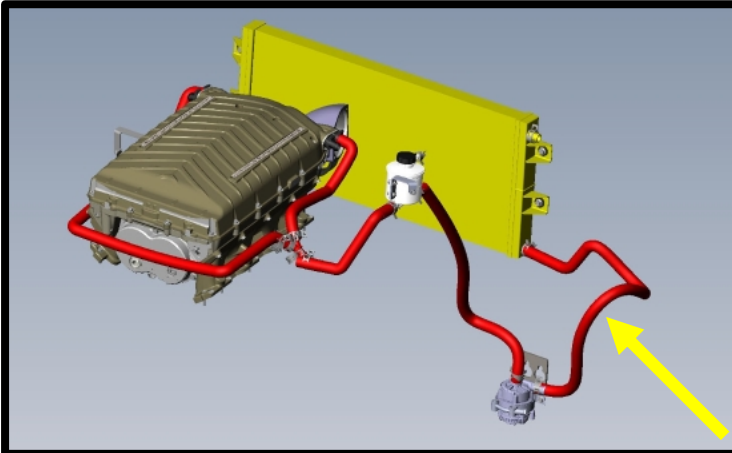

92. Install the preformed hose #3103256 from the LTR outlet (top fitting), under the airbox to the previously routed Y fitting feeding intercooler (rear fittings). Secure hose using supplied #16 pinch clamp. **NOTE:** Secure hose with zip ties for clean installation.

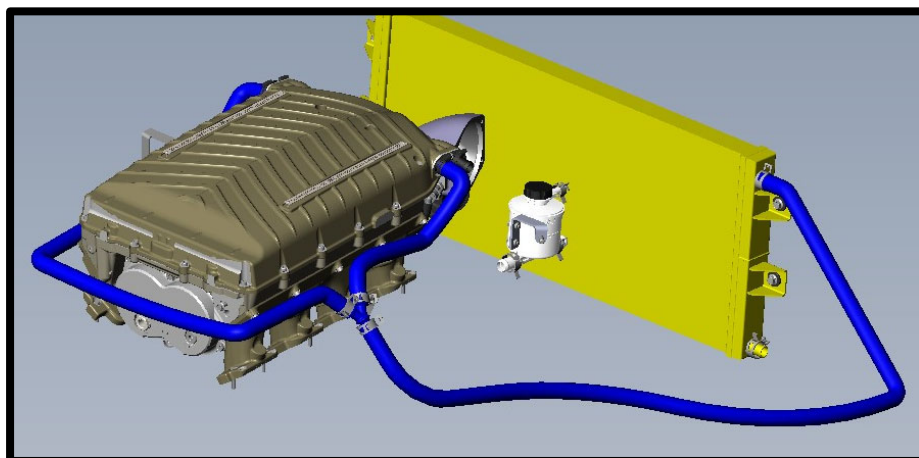
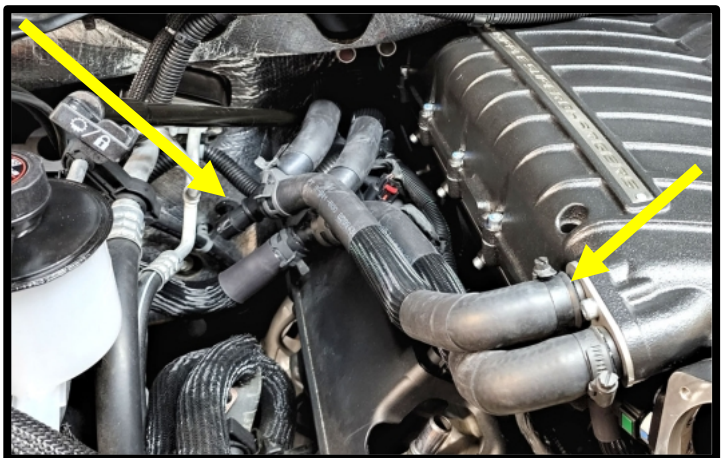
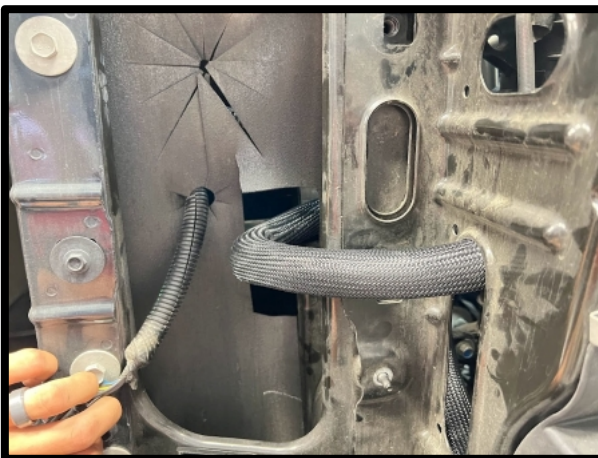

93. Install the supplied hose #3103149 from the filler reservoir front facing barb to the IC pump feed fitting. Secure with supplied #16 pinch clamp. Install supplied reservoir vent hose to 3/8" barb. Secure with #12 pinch clamp. Route along filler reservoir outlet hose, away from heat and exhaust. **NOTE:** Secure hose with zip ties for clean installation.

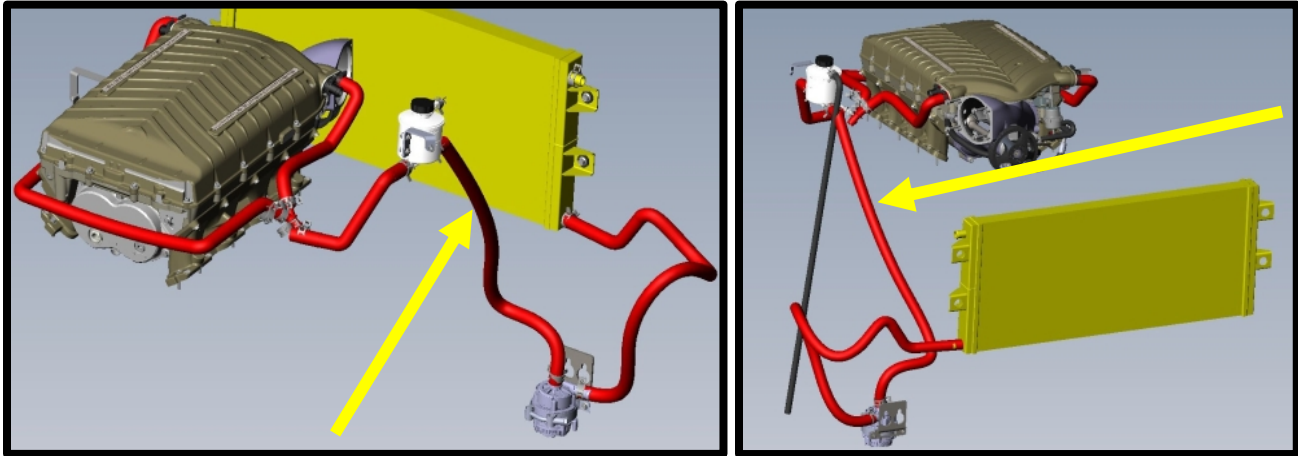

94. Install the supplied hose #3103274 from the RH Y (from front most fittings) to the rear filler reservoir barb. Secure with supplied constant tension clamp.

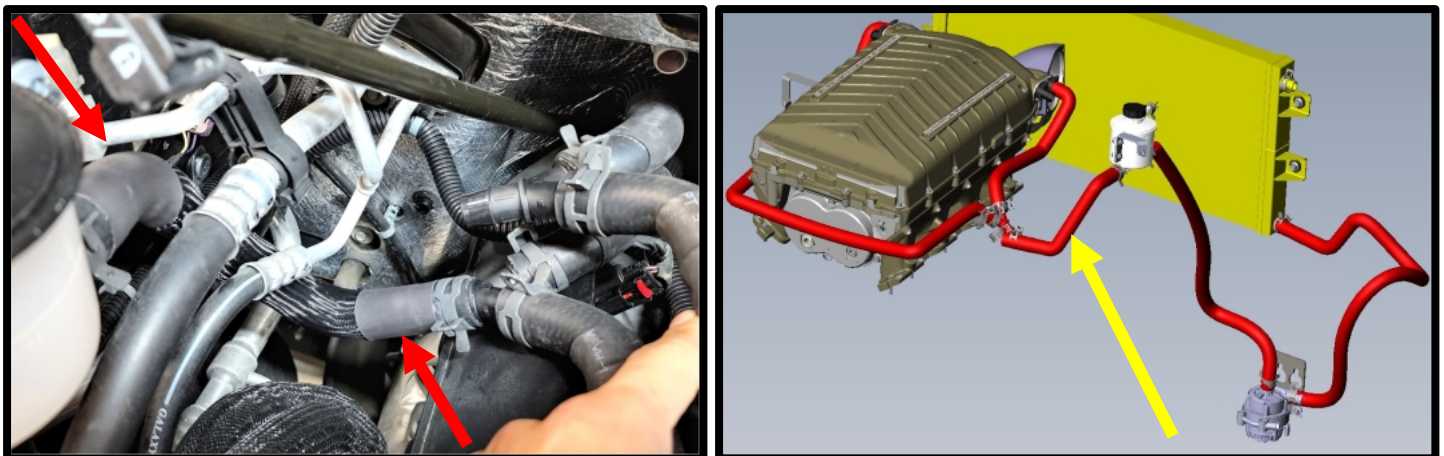

95. Using the supplied MAF to IAT pigtail to the MAF sensor factory connector. Connect the pigtail end to the MAF. Route the other end down the passenger side valve cover to the rear of the manifold. Connect the 2-way connector the supplied IAT sensor at the back of the manifold.

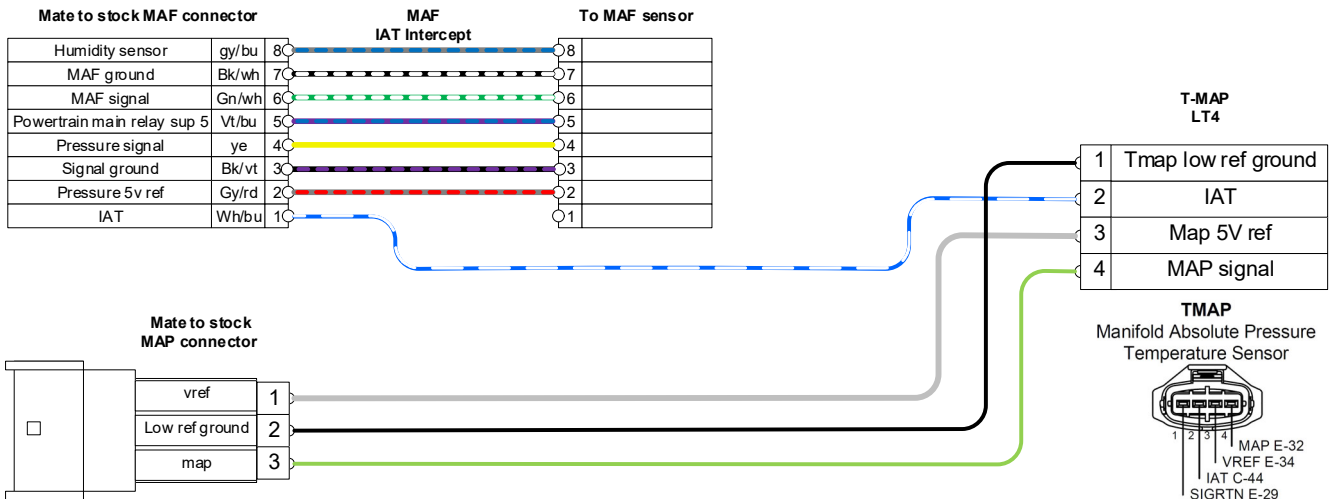

96. Remove the factory fuse box cover on driver side of engine compartment. Install the IC pump power eyelet to the factory post located at the rear of the fuse box. Remove factory nut, install IC pump eyelet and secure with factory nut.

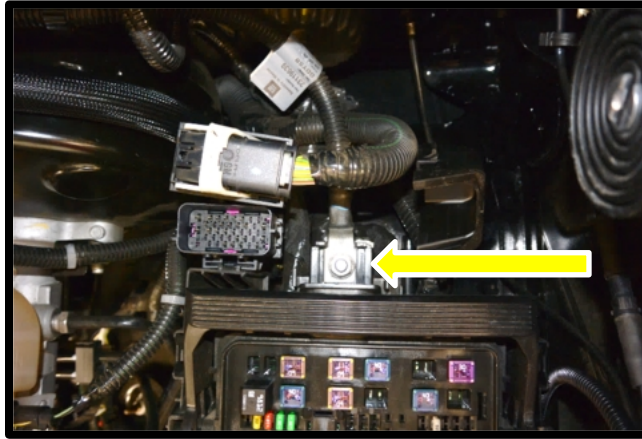

97. Install the IC pump ground to the factory stud and nut located on the driver side firewall. Remove factory nut, install the IC pump ground eyelet and secure with factory nut.

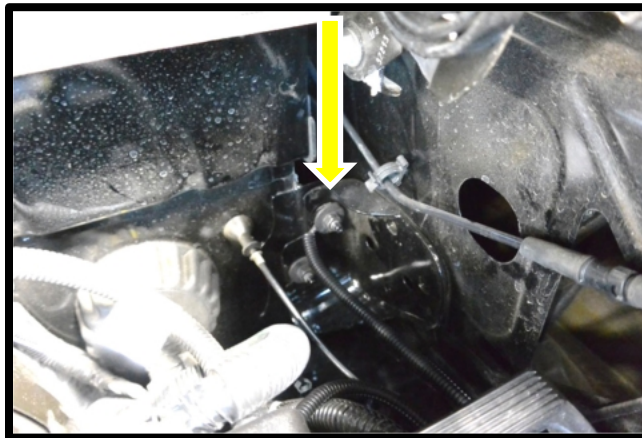

98. Remove the stock fuse from #46 (O2 Sensor B). Install it to the fuse tap (should have stock and supplied IC pump fuse in fuse tap). Install fuse tap with the two fuses back to #46 (O2 Sensor B). Make small notch in box for wire to come through box.

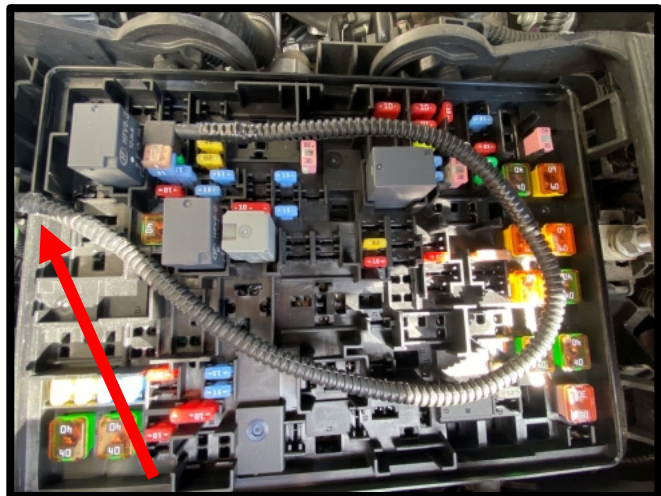
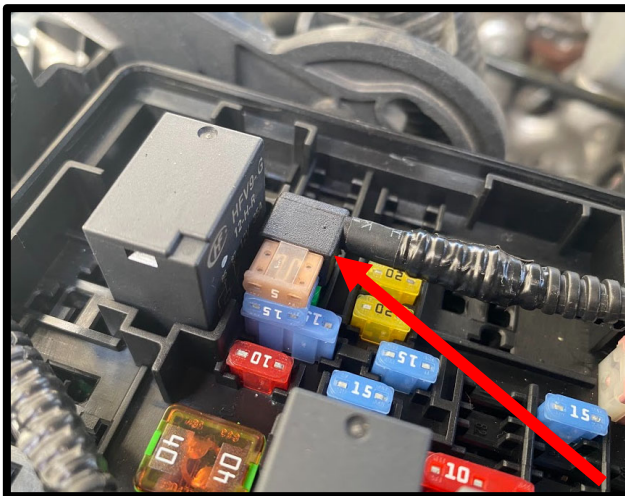

99. Install the intercooler relay and fuse holder to the factory driver side fender using the supplied 6mm x 20mm bolt/flat washer and the 6mm nut, washer and lock washer to secure.



100. Route the IC pump 2-way connector up front under driver side headlight area, below bumper and to the IC pump. Push connector until it clicks and locks in place.

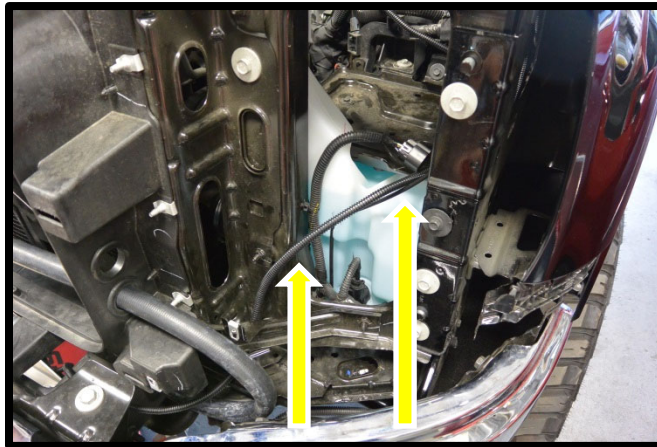

101. Secure wiring harness and IC pump outlet line with zip ties.



102. **(14-20 SUV ONLY)** Remove the stock crimp fitting and stock straight quick connect fitting from heater hose. Use the supplied 90deg 15.82mm quick connect fitting to end of stock hose. Secure hose using supplied #8 hose clamp. Reinstall the stock Tee fitting previously removed. Install this fitting to end of stock tee fitting. Route under other heater line, secure to tee fitting.



103. **(14-18 TRUCK ONLY)** Reinstall stock heater tube quick connect fittings.



104. **(5.3L)** Install the factory throttle body oring to the new throttle body adapter. Install the supplied throttle body adapter gasket and install adapter to the SC inlet using the supplied (4) 6mm x 30mm FHCS (4mm allen socket), torque to 80 in/lbs.

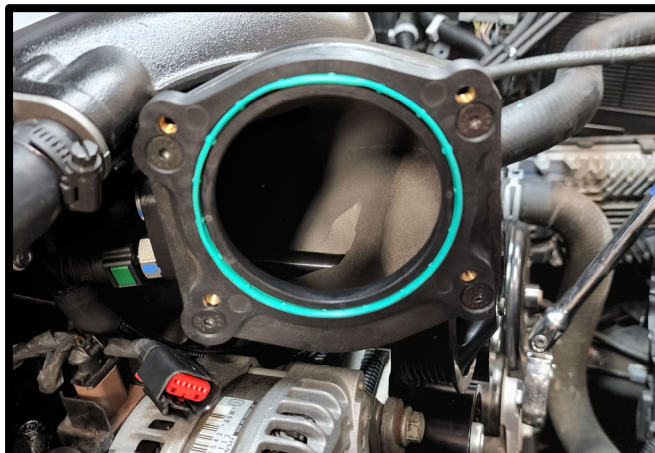

105. **(5.3L)** Use the supplied (4) 6mm x 40mm SHCS flange bolt to secure throttle body to throttle body adapter using a 10mm socket, torque to 80 in/lbs. **Loctite™ (#242 blue) threads.**

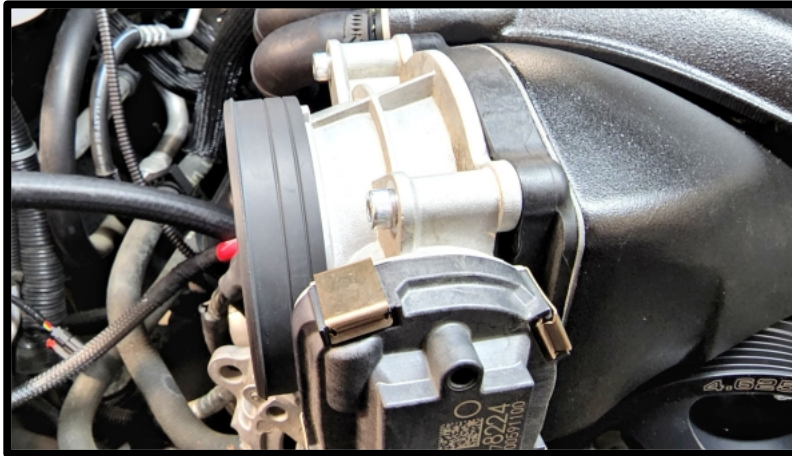

106. **(5.3L Only)** Install supplied rubber boot to throttle body flange.

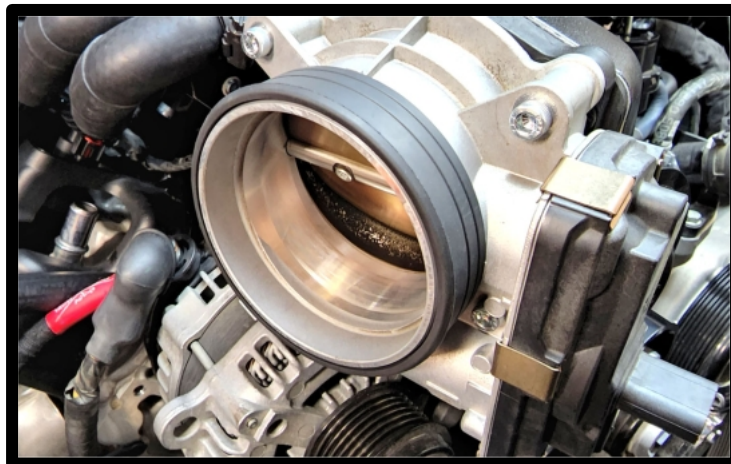

107. **(6.2L)** Install the supplied gaskets on both sides of the throttle body adapter. Use the supplied (4) 6mm x 60mm HHFCS bolts to mount the stock throttle body to the SC inlet using a 10mm socket. Torque to 89 in/lbs.



108. Install the supplied high flow filter element to the factory location. Reinstall the factory airbox lid to the factory airbox. Secure using the factory (4) fasteners and an 8mm socket.

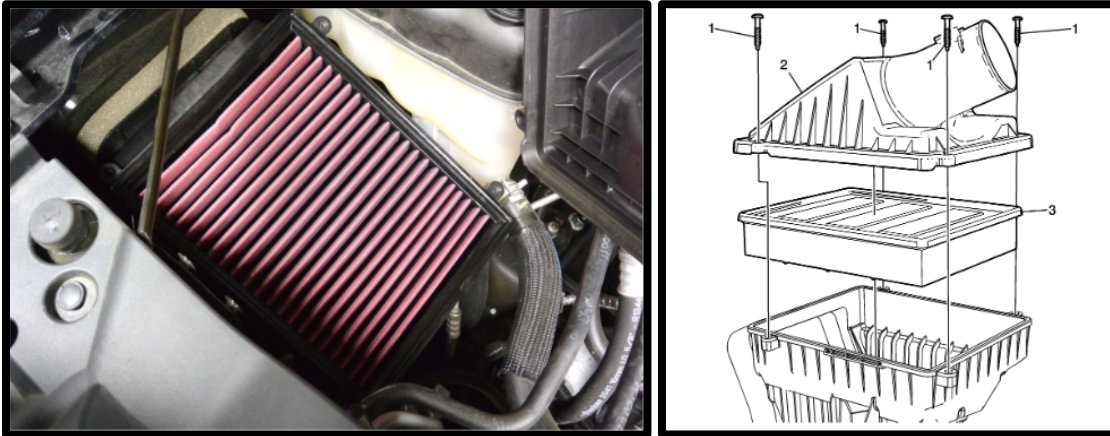

109. Install the (2) wire harness retainers and the (2) 1/2" 90deg hose barbs to air inlet tube.

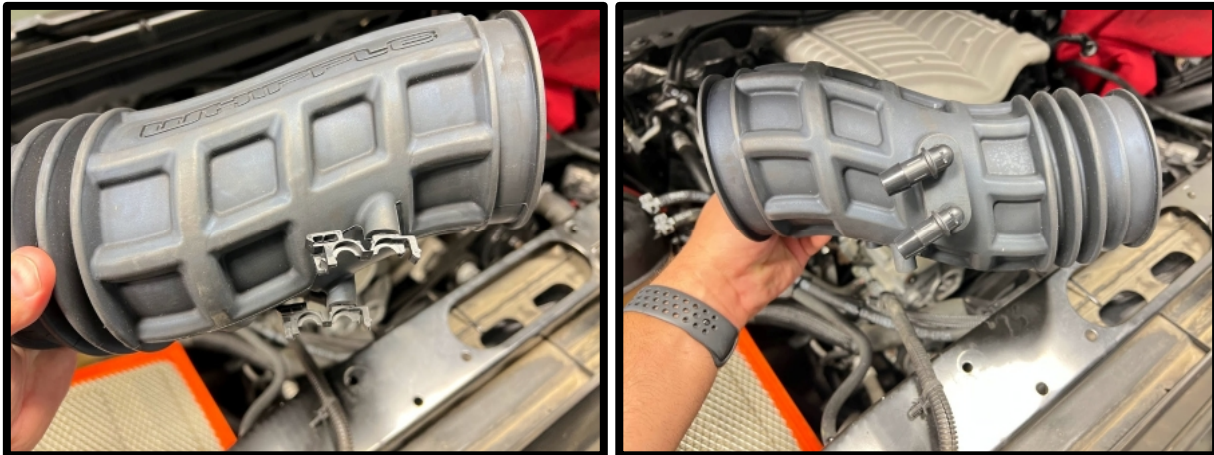

110. Install the supplied Whipple air inlet tube to the factory MAF housing and secure with the supplied #64 clamps. Install other end of inlet to the supplied silicone hose to the factory throttle body using supplied clamp.



111. Route the throttle extension under the air inlet tube, connect to throttle body and stock connector. Secure harness in clips, away from the belt. **NOTE:** Support wires when pressing together on female extension to stock harness.

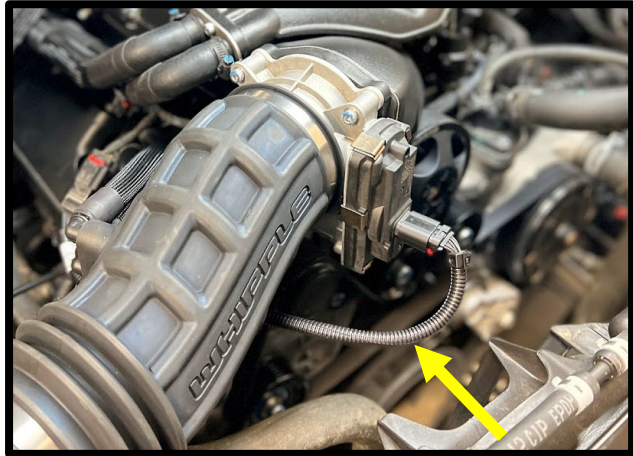
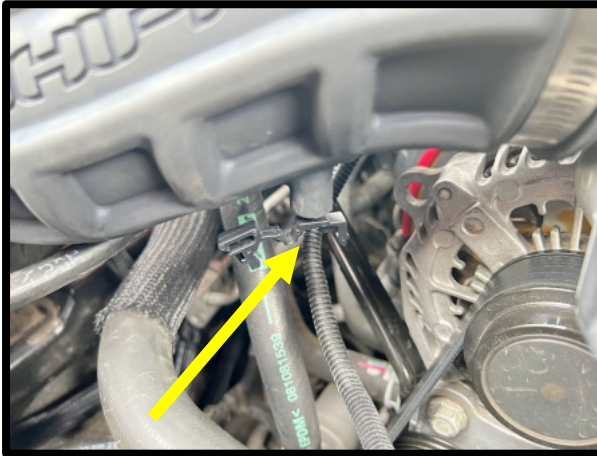

112. Install the driver side 1/2" x 27" PCV/Vent hose to the quick connect fitting on the passenger side valve cover. Route under the SC, to the bottom port on the inlet tube. Push until it locks in place.

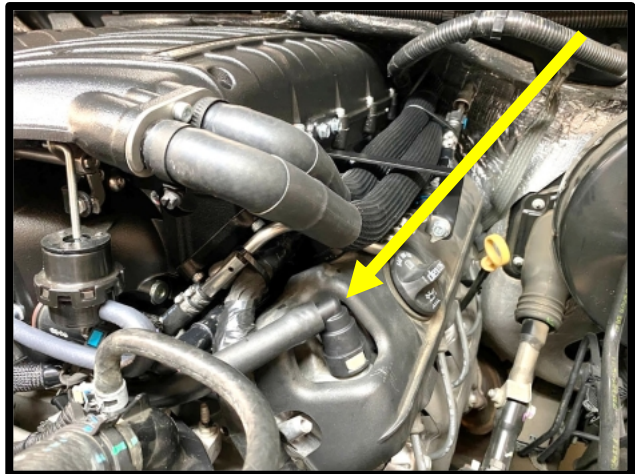
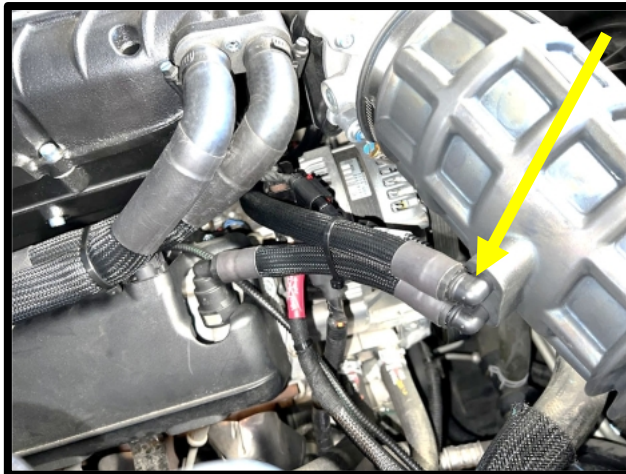

113. Install the passenger side 1/2" x 7" PCV/Vent hose to the quick connect fitting on the passenger side of the air inlet tube and connect to the passenger side valve cover. Push until it locks in place.

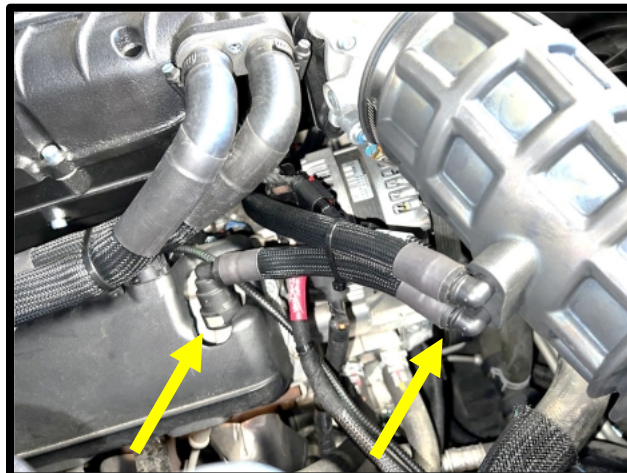

114. Connect Whipple MAF connector to MAF sensor by routing under the MAF sensor. Press together until it clicks and locks and place.

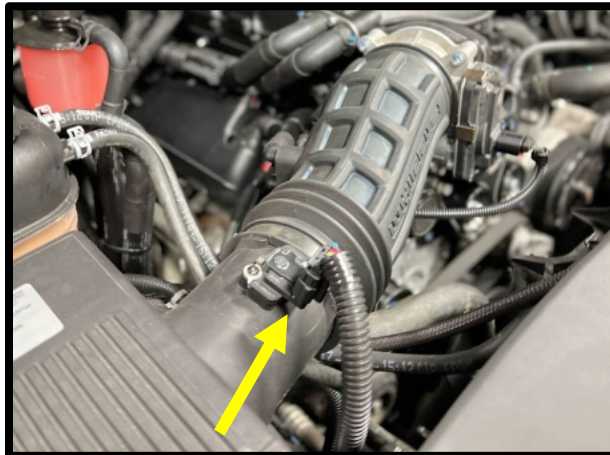

115. Refill the Engine coolant. Verify that your coolant drain is closed, and use a filter/strainer to pour the recycled coolant/water mixture that you drained from the radiator. If necessary, top off with a **GM approved engine coolant**. Whipple also recommends running 2 bottles of Redline Water Wetter which can be found at most automotive parts stores. **⚠ WARNING!! DO NOT USE TAP WATER OR ANY NON GM APPROVED ENGINE COOLANT, THIS WILL CAUSE CORRISION IN THE SYSTEM.** Start engine to completely fill system.
116. Reinstall front driver side headlight by using the factory (4) fasteners and a 10mm socket.
117. Remove the front fascia from the front grille by releasing the tabs.
118. Reinstall factory grille assembly by installing the (10) factory fasteners (T15 torx and 7mm socket wrench).
119. Reinstall the front fascia by pressing back into place until it locks in place.



**The electric water pump used on the Whipple SC system has a built-in micro-processor that will vary pump cycle speed when air bubbles are present in the system. If a significant amount of air is trapped in the system, the pump may cycle at a lower speed and pulsations are likely to occur resulting in poor cooling performance.**

**For the best result, it is highly recommended to use a Radiator Cooling System Vacuum Purge and Refill Kit to properly evacuate the air from the intercooler system before filling the 50/50 mixture of coolant and distilled water. If one is not available, the following procedure will be adequate.**

120. Attach the negative cable to the battery and tighten.
121. Using a Lisle 24680 Spill-Free Funnel, or equivalent, secure the appropriate filler neck adapter to the filler reservoir.
122. Attach the funnel and fill with a 50/50 mixture of coolant and distilled water until the funnel is half full. Whipple recommends Zerex G-05 to match the stock color. The Whipple IC system is compatible with all common types of antifreeze, it is customer preference. Note: Whipple also recommends 1 bottle of Red Line Water Wetter or equivalent. Never use tap water, this will cause corrosion and destroy the system.

123. Turn the ignition to the **ON** position, after a brief delay, the electric pump motor will cycle. Air bubbles will begin to rise to the filler tee as the coolant level drops, continue to fill while pump is running. Once its done filling, turn the ignition key **OFF**, the level will drop, top off with fluid. Reinstall filler cap and turn the ignition **ON** and let run for 15 seconds. Turn key **OFF**, remove cap to release air. Repeat until the filler tee holds just above the **MIN** level with key **OFF**. To build more pressure in the intercooler system, try squeezing the intercooler hoses while the pump is cycling. Building pressure in the system will help push the trapped air from the intercooler system to the filler tee. It also helps to lift the filler neck 4"-8" higher than its mount to help purge the air. **NOTE:** Do not let the coolant level in the funnel run empty as this may introduce more air into the system.
124. Cycle the ignition to the ON position again and repeat until the sound of the electric pump is continuous without any pulsation and the fluid level is met at the filler cap. **NOTE: During water pump start-up, it is normal for a slight pulsation to occur. Once the pump has reached its maximum cycle speed, no pulsations should be present. If any pulsations occur, there is air in the system. NEVER GO WOT UNTIL AIR IS BLEDED OUT!**
125. Several drive cycles may be required to completely purge the air from the intercooler system. During a drive cycle, the intercooler system will build up pressure as the supercharger temperature increases. Any residual air trapped in the system will have to be bled out when the cap is removed. Use a rag when removing in case there is excess pressure. **CAUTION: Never go WOT until air has been bled from IC system, engine failure could occur if not bled properly.**

**WARNING: Always avoid removing the filler neck cap when the system is hot. The hot coolant is under pressure and may spray out causing burns.**

126. Clean the inner area of the gas door with acetone. Attach the "91 OCTANE OR HIGHER" decal to the gas tank fill cap or door.



127. Turn the Ignition key on, DO NOT START THE ENGINE. Inspect for any leaks such as fuel, coolant, and intercooler coolant, correct as required.
128. Start the engine and let it idle for 30 seconds and then shut the engine off. Check the SC oil and correct if needed.
129. Start the engine and let it idle. The engine should idle normally between 600-700 rpm. Inspect for leaks. After running for 2 minutes turn off engine and inspect the level in the ENGINE radiator and the Intercooler tank. With the key in the ON position engine off, inspect the coolant in the intercooler tank, the coolant should flow in the tank. Top off as necessary.
130. Before driving make sure that you have 91 or higher-octane fuel in the system. NOT ½ tank of 87 and ½ tank of 91, ALL 91 or better fuel in the system. Do not use octane booster in fuel to get to 91.
131. DO NOT use aftermarket air filter box or duct with the supplied Whipple calibration. The Whipple calibration is designed to work with the factory air box, factory MAF and Whipple air inlet duct and nothing else. Changes to the air inlet system will require a custom calibration which Whipple does not provide and is not 50-state emissions legal.

132. **(Complete kits only)** Install the supplied 50-state legal sticker to factory radiator shroud or on hood near factory emissions sticker. Clean area with acetone or cleaning agent before installing.



133. Note that the ambient air temp shown on the digital display in the dash takes 2 minutes over 55MPH to reset to read correctly after the PCM has been flashed. It will read 32deg until that time.
134. Test drive vehicle for the first few miles under normal driving conditions. Listen for any noises, vibrations, engine misfire or anything that does not seem normal. The supercharger does have a slight whining noise under boost conditions, which is normal.
135. Re-check the radiator and intercooler reservoir coolant level regularly over the first 1,000 miles, top off level as needed. **NOTE: It is very common for installers to leave air in the system, if pump is varying in RPM, it has air in the system.**
136. After the initial test drive, go through the belt tensioner process again. When next you start driving, gradually work the vehicle to wide open throttle runs. Listen for any engine detonation (pinging). If engine detonation is present, let up on the throttle immediately. Most detonation causes are low octane gasoline still in the tank. Continued detonation can cause engine damage, contact Whipple if you're have this issue.
137. If you have questions about your vehicles performance, please check with your installation facility or call Whipple Superchargers at 559.442.1261, Monday through Friday from 8am to 5:00pm, pacific time or email questions to [tech@whipplesuperchargers.com](mailto:tech@whipplesuperchargers.com).

**⚠ WARNING!!** Verify the bypass actuator is working properly. To monitor, look at the bypass arm when the motor is not running. Start engine and verify that the actuator arm has opened. This arm will be extended when the engine is above 1" of vacuum (boost) and will be open when there is more than 1" of engine vacuum.

---

## **MAINTENANCE AND SERVICE**

Be sure to follow the maintenance and service recommendations below to optimize the life and performance of your Whipple Supercharged vehicle. For best performance and continued reliability, it is essential to adhere to the following guidelines:

1. Use only premium grade fuel (91-octane or higher).
2. Always listen for any sign of spark knock or pinging. If present, discontinue use immediately and consult your vehicle owner's manual.
3. Do not operate the vehicle at large throttle opening if the MIL lamp is on steadily. This indicates an electronic engine control malfunction: reduce throttle opening and consult your vehicle dealer.
4. Check the supercharger oil level at every engine oil change. Add Whipple SC oil to the supercharger if required. Do not overfill the supercharger rear gear case.
5. Change the oil in the supercharger every 100,000 miles, if changing the speed of the SC, change oil every 50,000 miles. Use Whipple SC oil only.

---

***Severe damage to the compressor will occur if you overfill the supercharger rear gear case.***

---

6. Do not operate the vehicle at large throttle opening if the MIL lamp is on steadily. This indicates an electronic engine control malfunction: reduce throttle opening and consult your vehicle dealer.
7. Inspect and clean your high-flow air filter element every **10,000 miles**. Replace as necessary.
8. Check intercooler fluid level every 7,500 miles.
- 9. Replace spark plugs every 20,000 miles. Only run specified plugs, Denso ITV22 or NGK 6510 (.032" gap).**
10. Follow your factory service intervals for oil changes and other typical maintenance items.
11. Check the supercharger/accessory drive belt. Adjust or replace as required.

---

***Any modification to your vehicle's new computer program may cause serious damage to the engine and/or drive train.***

---

## **CONGRATULATIONS**

Your new Whipple Supercharger is engineered to significantly increase your engines power across a broad range of RPM's. It is Whipple's goal to improve your driving experience for many miles and years to come.

Whipple Superchargers operate as an air pump and contain internal rotors that are driven by the engine's crankshaft and serpentine belts. The supercharger compresses outside air and channels it into the engine's intake ports. Because of their design, superchargers may generate some additional noise over the standard, normally aspirated induction system.

At idle, you may hear a medium-pitch rattle from the supercharger main housing. This will diminish at about 400-500 rpm above idle.

You may also experience a muffled high-pitched whine during acceleration. This is caused by the pumping action of the supercharger compressing air and only occurs during boost conditions. It is inaudible during part-throttle acceleration.

These are normal noises associated with any supercharger and have no effect on supercharger performance or engine durability.

Your supercharger is warranted by Whipple Superchargers, please see your terms and conditions on the back of your invoice for more information in regard to the limited warranty. NOTE: Whipple Superchargers will not authorize any warranty repair work or supercharger replacement for normal noise