



2021 AND UP F150/RAPTOR/TREMOR

STAGE 1 PERFORMANCE KIT
2.7L/3.5L ECOBOOST

**WHIPPLE PART NUMBER: #EB-8113, EB-8113-NFT, EB-8118, EB-8118-NFT, EB-8113-SH,
EB-8113-SH-NFT**



WHIPPLE SUPERCHARGERS
3292 NORTH WEBER AVE
FRESNO, CA 93722
TEL 559.442.1261
FAX 559.442.4153

WWW.WHIPPLESUPERCHARGERS.COM

PREMIUM FUEL ONLY (91 OCTANE OR BETTER ALWAYS) RON+MON/2

CALIFORNIA AIR RESCOURCE BOARD EXECUTIVE ORDER #D231-80

**COMPETITION BASED PRODUCT MAY BE USED SOLELY ON VEHICLES USED IN SANCTIONED COMPETITION WHICH
MAY NEVER BE USED UPON A PUBLIC ROAD OR HIGHWAY**

INTRODUCTION

Before beginning installation, please read this manual and important notes:

- Please read the installation manual and verify that all items are present. If you are missing hardware or have any questions, please contact your dealer or Whipple.
- **Premium fuel (US 91 octane) is required** to prevent spark-knock/detonation under certain operating conditions. Other countries must meet US 91 octane standards, RON+MON/2. If fuel of less than 91-octane is present in the vehicle fuel tank, the tank must be completely drained and refilled with 91 or higher octane to 1/8th of a tank.
- **91 octane should always be from Tier 1 fuel supplier such as Chevron, Shell, Unocal, Texaco, Sunoco. Bargain fuel (Example: Costco, Safeway, Sam's Club, Vons, Valero) does not perform well and will result in lower power and possible engine damage.**

COMPETITION BASED PRODUCT MAY BE USED SOLELY ON VEHICLES USED IN SANCTIONED COMPETITION WHICH MAY NEVER BE USED UPON A PUBLIC ROAD OR HIGHWAY, UNLESS PERMITTED BY SPECIFIC REGULATORY EXEMPTION (VISIT THE "EMISSIONS" PAGE AT [HTTP://WWW.SEMASAN.COM/EMISSIONS](http://www.semasan.com/emissions) FOR STATE BY STATE DETAILS.

COMPETITION BASED PRODUCT IS LEGAL IN CALIFORNIA ONLY FOR RACING VEHICLES WHICH MAY NEVER BE USED, OR REGISTERED OR LICENSED FOR USE, UPON A HIGHWAY.

IT IS THE RESPONSIBILITY OF THE INSTALLER AND/OR USER OF THIS PRODUCT TO ENSURE THAT IT IS USED IN COMPLIANCE WITH ALL APPLICABLE LAWS AND REGULATIONS.

RECOMMENDED TOOLS AND SUPPLIES

The following items are not included in this supercharger kit and it is strongly recommended that they're used for ease of installation or maximum performance.

Safety glasses, 3/8" torque wrench, 3/8" socket wrench, 8mm, 10mm and 15mm sockets, screw driver, trim pad tool (for pushpin removal), floor jack, axle stand.

PRE-INSTALLATION CHECKLIST

Before installing your Whipple Kit, complete the following checklist.

1. Verify Condition of Vehicle: Before the upgrade kit is installed, ensure the engine runs smoothly and that the factory malfunction indicator light (MIL) is off. Only install the supercharger kit if the engine runs smoothly *and* the MIL is off.
2. **!! CAUTION !!** This product is intended for use only on **STOCK, UNMODIFIED, WELL-MAINTAINED engines. Installation on a worn-out or modified engine is not recommended without factory computer and fuel system modifications. Custom engine configurations could require custom tuning and other supporting modifications.**
3. Verify Fuel System: Upgrade systems should only be installed on vehicles that have new or clean fuel filters.
4. Assess Cleanliness of Installation Area: Make sure your work area and the under-hood area are free from debris. This supercharger is a high-quality, close-tolerance compressor and must not be subjected to contamination by dirt or any type of foreign material. If necessary, vacuum around engine to remove any foreign material.
5. **!! CAUTION !!** Identify Kit Components: Before beginning installation, identify all the components of your Whipple Kit and ensure all items are present and undamaged.

SAFETY PRECAUTIONS



CAREFULLY READ THE IMPORTANT SAFETY PRECAUTIONS AND WARNINGS BEFORE PROCEEDING WITH THE INSTALLATION!

Appropriate disassembly, assembly methods and procedures are essential to ensure the personal safety of the individual performing the kit installation. Improper installation due to the failure to correctly follow these instructions could cause personally injury or death. Read each step of the installation manual carefully before starting the installation.

- Always wear safety glasses for eye protection.
- Place the ignition switch in the off position.
- Always apply the parking brake when working on vehicle.
- Block the front and rear tire surfaces to prevent unexpected vehicle movement.
- Operate the engine only in well-ventilated areas to avoid exposure to carbon monoxide.
- Do not smoke or use flammable items near or around fuel system.
- Use chemicals and cleaners only in well-ventilated areas.
- Batteries can produce explosive hydrogen gas which can cause personal injury. Do not allow flames, sparks or flammable sources to come near the battery.
- Keep hands and any other objects away from the radiator fan blades.
- Keep yourself and your clothing away from moving parts when the engine is running.
- Do not wear loose clothing or jewelry that can be caught in rotating or moving parts.



****NOTICE:** Installation of Whipple products signifies that you have read this document and have agreed to the terms stated within.

It's the purchaser's responsibility to follow all installation instruction guidelines and safety procedures supplied with the product as it's received by the purchaser to determine the compatibility of the product with the vehicle or the device the purchaser intends to install the product on.

Whipple assumes no responsibility for damages occurring from accident, misuse, abuse, improper installation, improper operation, lack of reasonable care or all previously stated reasons resulting from incompatibility with other manufacturer's products.

There are no warranties expressed or implied for engine failure or damage to the vehicle in any way, loss of use or inconvenience or labor reimbursement. This includes merchantability and fitness.

The information contained in this publication was accurate and in effect at the time the publication was approved for printing and is subject to change without notice or liability. Whipple reserves the right to revise the information presented herein or to discontinue the production of parts described at any time.

PCM CALIBRAITON NOTICE

Your Whipple Performance kit includes a PCM reflash. You must follow the included Tomahawk Flash Tool instructions to request your calibration. NOTE: Whipple does not offer custom tuning. **Calibrations are provided for 100% stock vehicles with an exception to cat-back exhaust systems. Long tube headers, high flow cats and other engine mods are not supported. Calibrations can take up to 48 hours to fulfill, request before starting installation.**

INSTALLATION INSTRUCTIONS

It is strongly recommended that you read through this guide **before** you begin installing the Whipple Kit.

1. Follow the supplied instructions for the Tomahawk flash tool. Please allow up to 48 hours for calibration.
2. Using an air hose, blow off any loose dirt or debris from engine compartment. If really dirty, then steam clean the engine compartment before proceeding to the next step.
3. Lift the vehicle using a floor hoist, if you do not have access to one, use a hydraulic floor jack and jack stands to raise the vehicle. NOTE: Jack stands must be used on a level surface and be securely seated. Failure to do so may result in personal injury or vehicle damage.
4. Remove the bolts and the spacer from the front underbody skid plate.

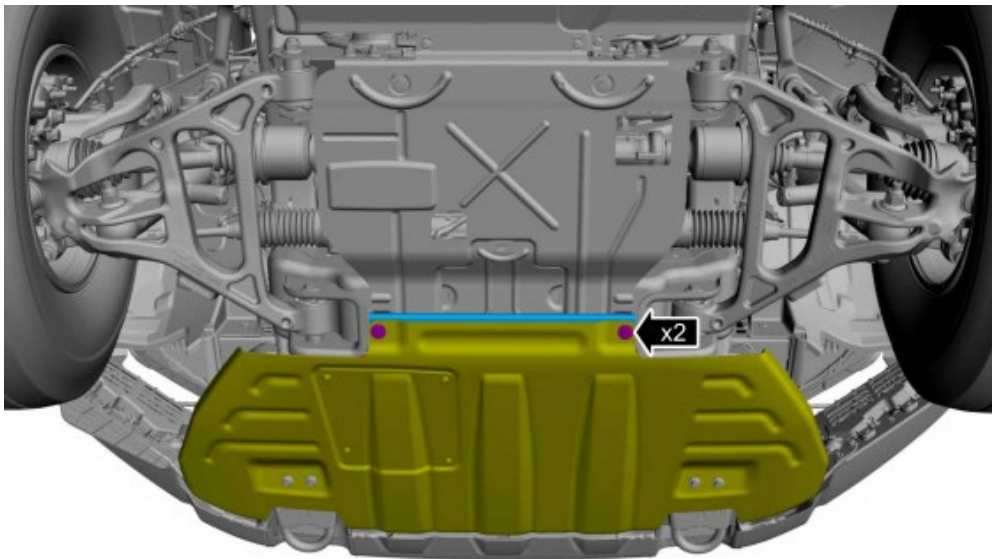

5. Remove the bolts and the front underbody skid plate.

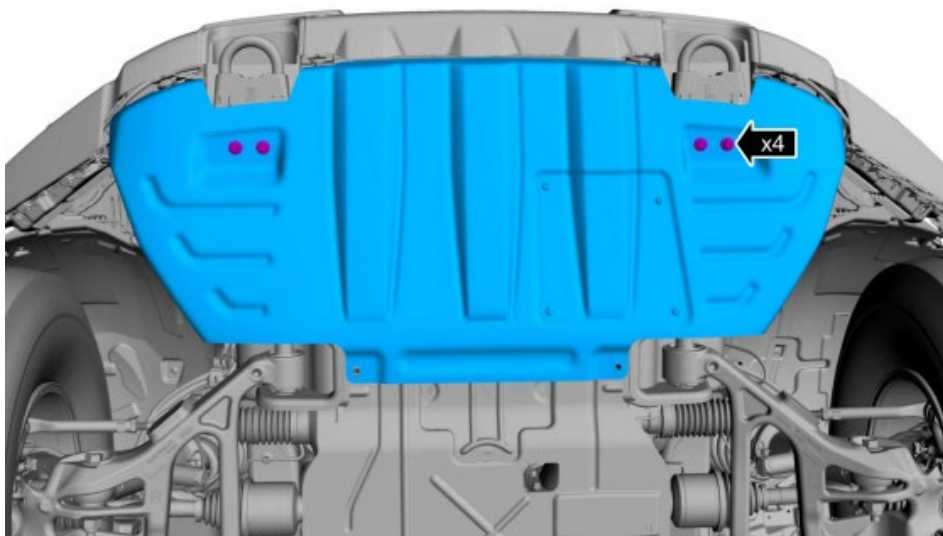

6. (When applicable) Disconnect the intercooler fan assembly. Detach the retainer and position the wiring harness aside.

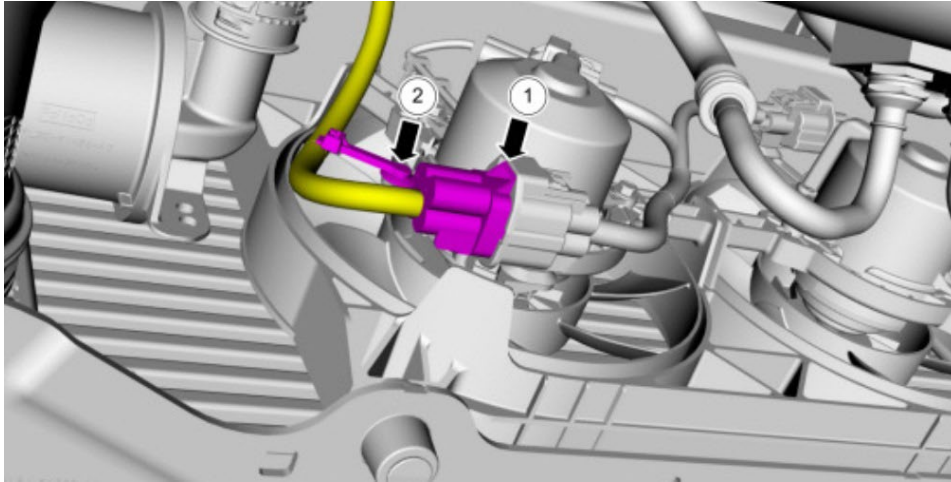

7. Remove the bolts using a 15mm socket, lower bracket and CAC cooling fan assembly.

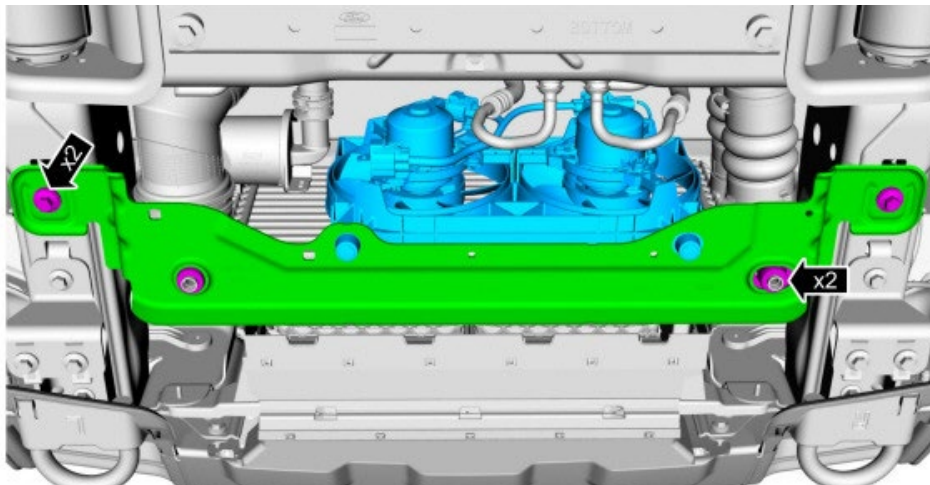

8. Using an axle stand, support the intercooler core.

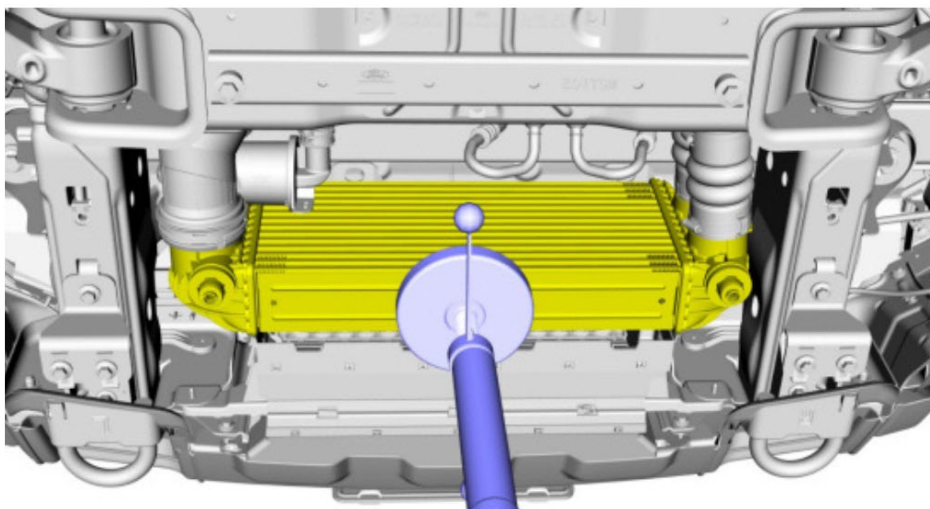

9. Loosen the clamps and position the intercooler intake pipes LH and RH aside.

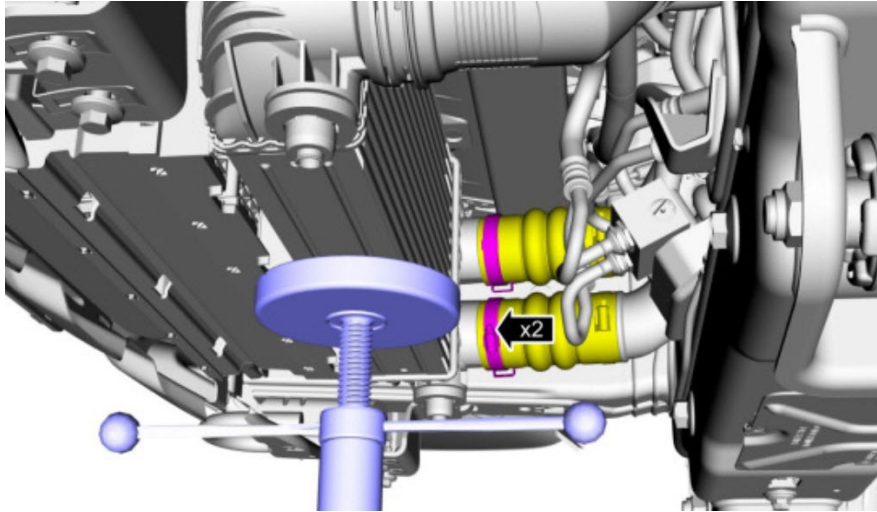

10. Disconnect the bypass valve tube. Release the clip and position the intercooler outlet pipe aside.

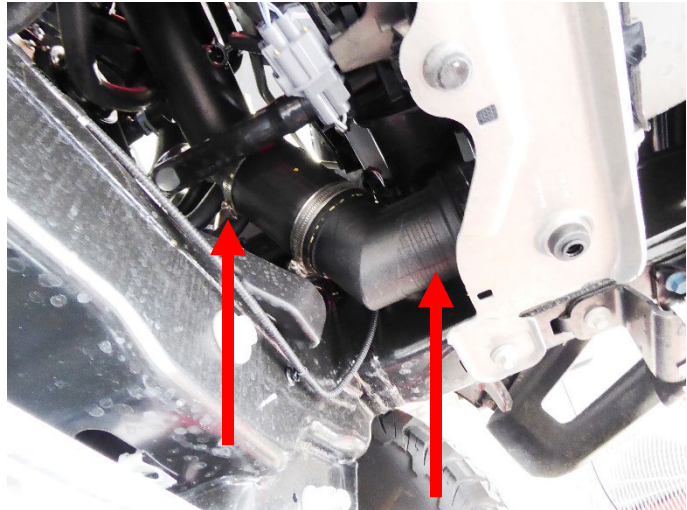
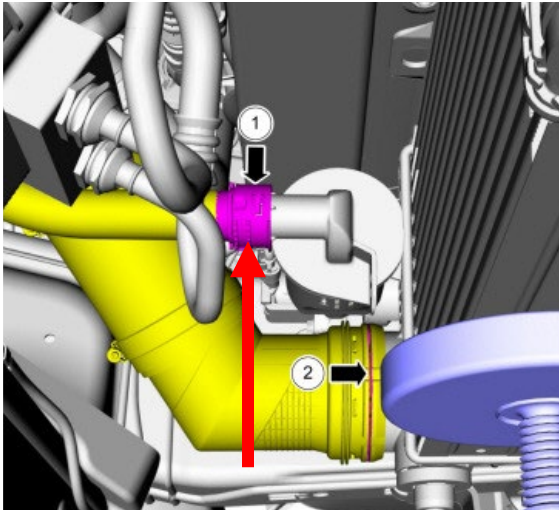

11. Remove the 45deg plastic elbow from the factory rubber hose by loosening the hose clamp (#2 in image).

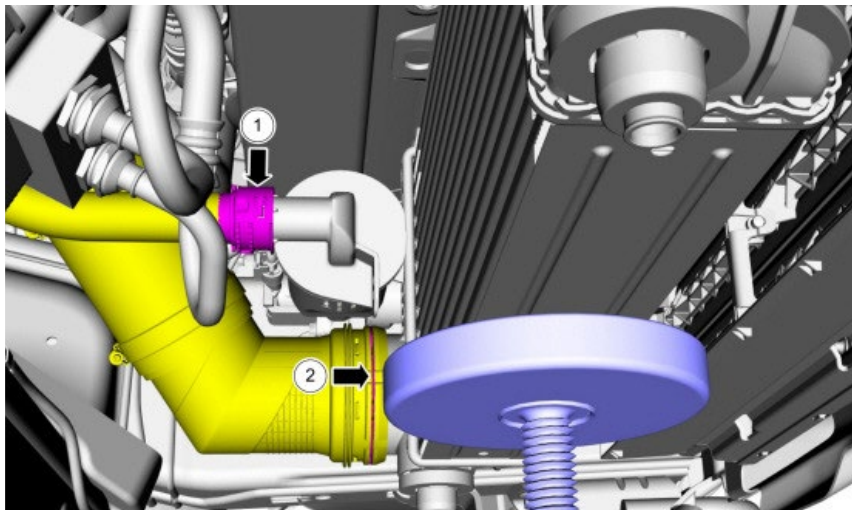

12. Disconnect the bypass valve electrical connector and place wiring harness aside.

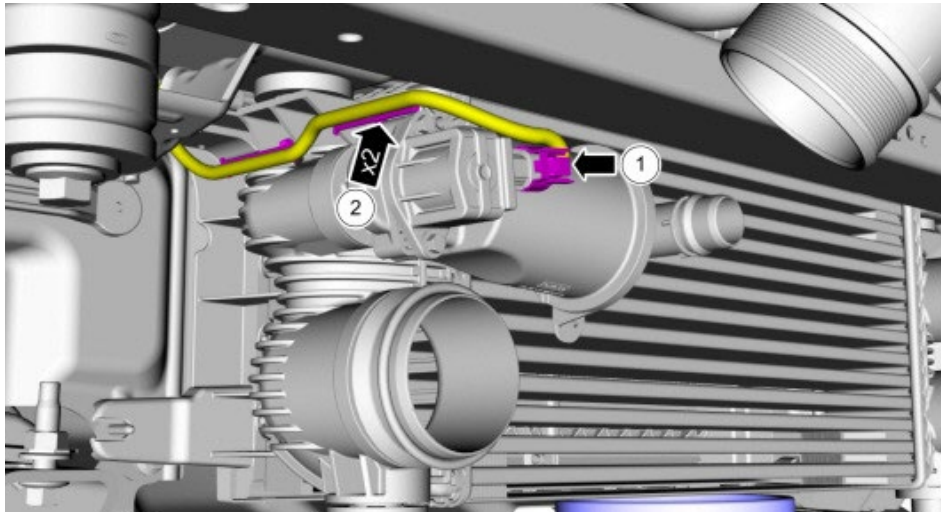

13. Lower the axle stand and remove the intercooler core from vehicle.

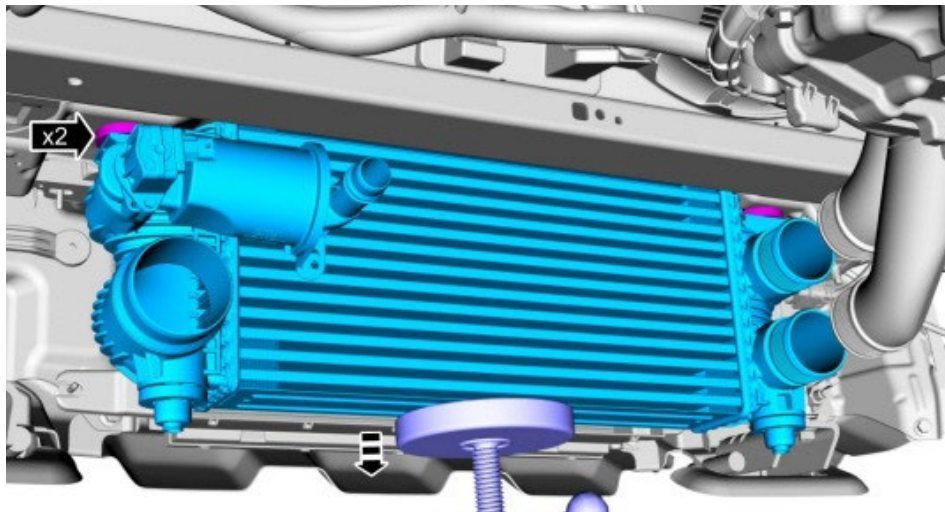

14. Remove the bolt from the turbocharger bypass valve using 8mm socket. Rotate the bypass and remove from intercooler.

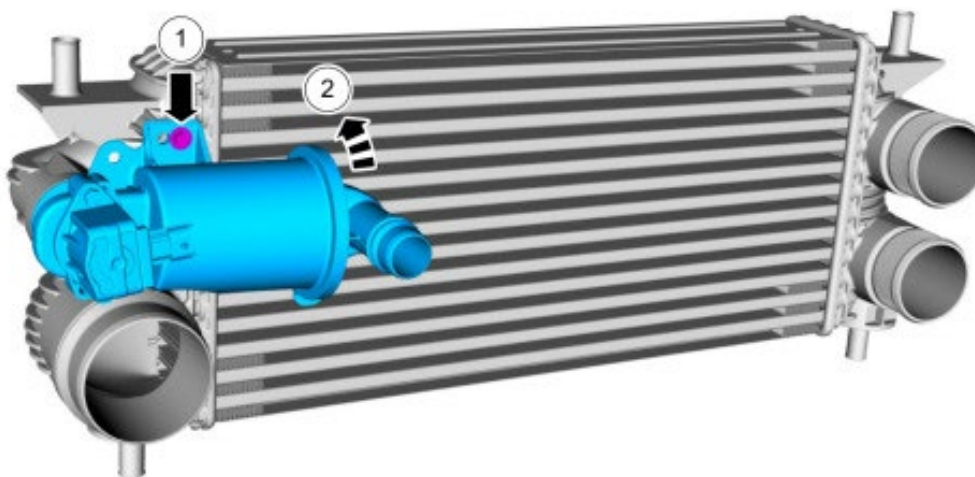

15. Mount the bypass valve to the new intercooler with the supplied 6mm x 10mm flanged hex headed bolt. Torque to 62 in-lbs with a 10mm socket.

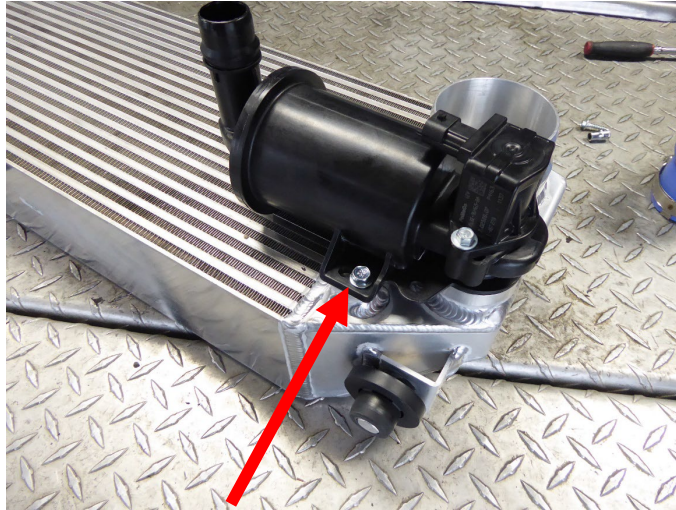

16. Transfer the rubber isolators from the OEM intercooler to the Whipple Cooler.

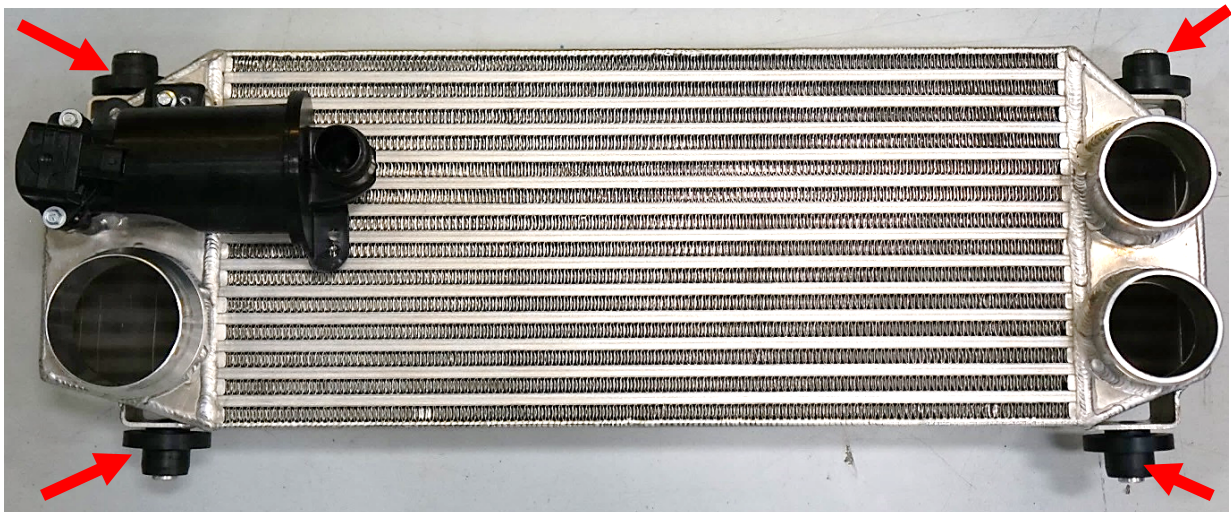

17. Install the fan assembly to the intercooler core and factory support bracket prior to reinstall.

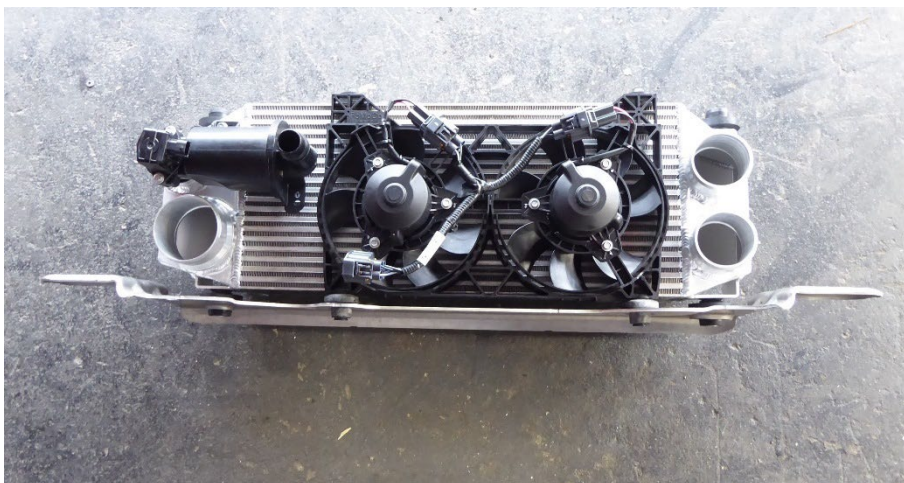

18. Remove the IC plastic trim section from the factory clips, this will not be reused with the larger intercooler core. **NOTE:** Expedition/Navigator will have to cut this for proper intercooler clearance. Give the intercooler face .25" to .50" of clearance.



19. Raise the axle stand and install the intercooler core to vehicle.

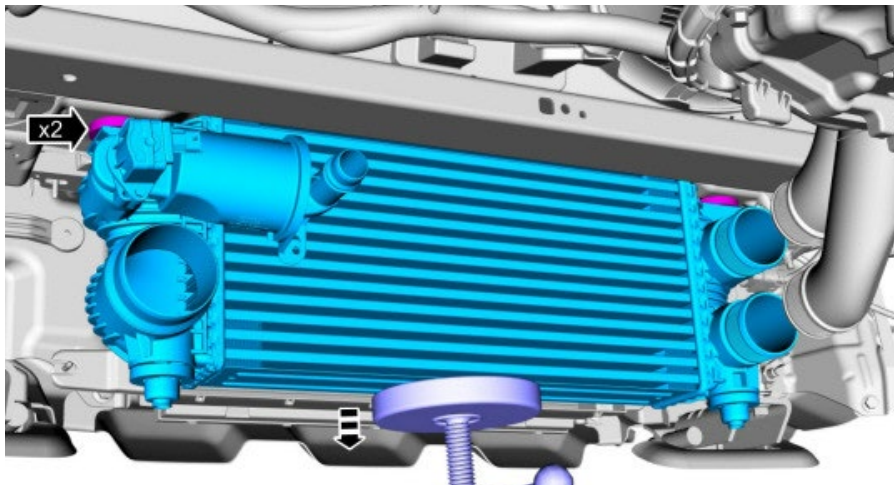

20. Connect the bypass valve electrical connector.

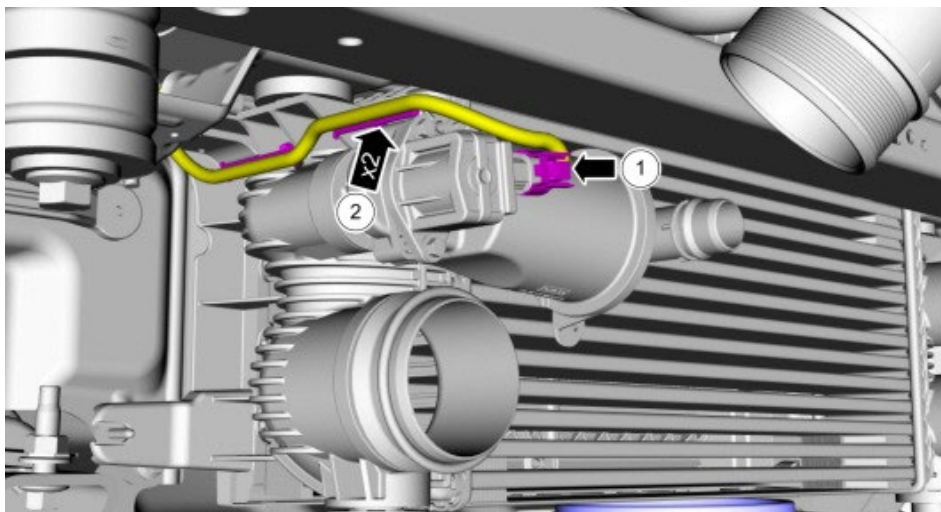

21. Connect the bypass valve tube and the supplied silicone 60deg outlet pipe. Install 3.25" x 3" hose coupler to 60deg hose and factory rubber hose. Secure stock hose and 60deg hose to coupler using stock clamp and supplied (1) 3.25" T-bolt clamp. Secure 60deg tube to intercooler using (1) 3.25" t-bolt clamp.

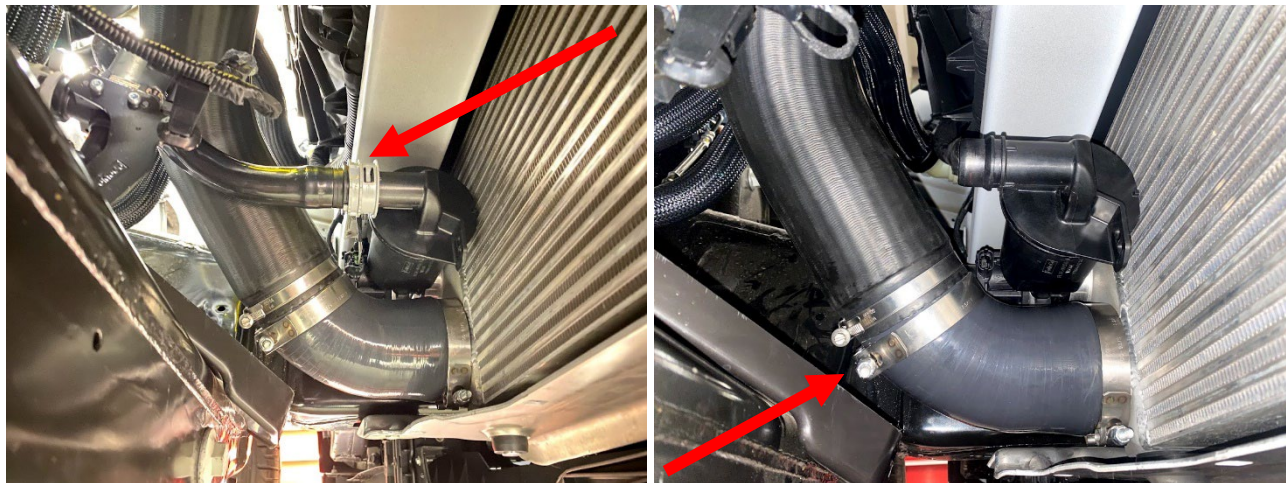

22. Install the clamps and position the intercooler intake pipes.

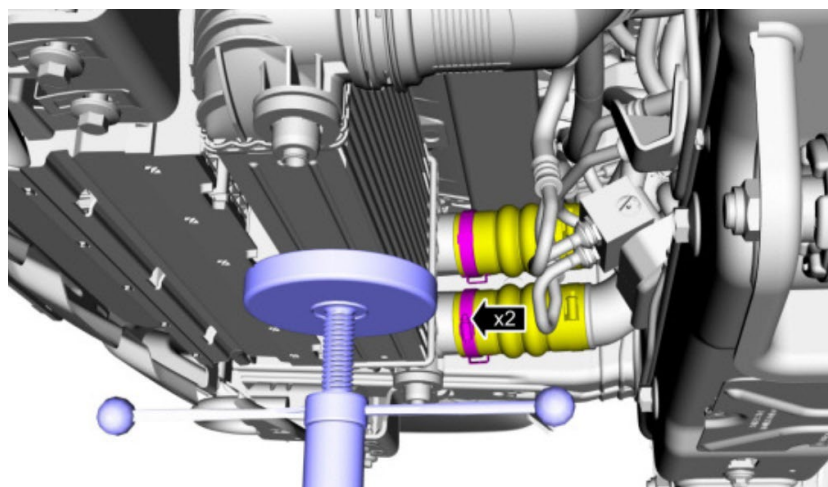

23. Install the lower bracket and fan assembly, secure with factory bolts. Torque to 30 ft-lbs.

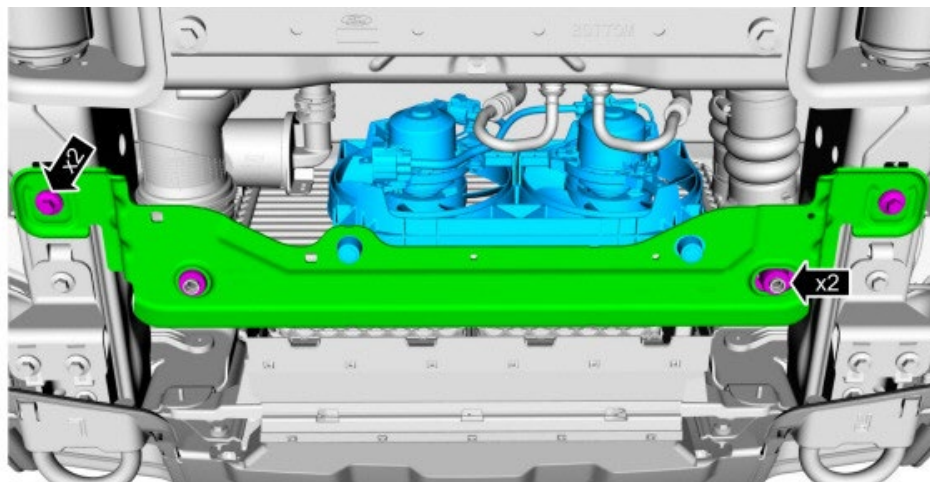

24. Connect the intercooler fan electrical connector.

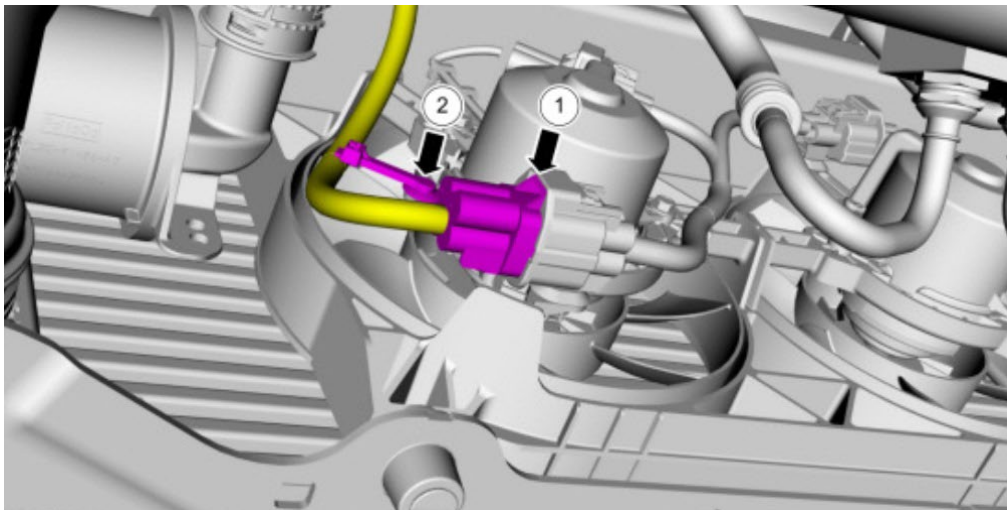

25. Reinstall the front underbody skid plate with factory hardware. Torque to 35 ft-lbs.

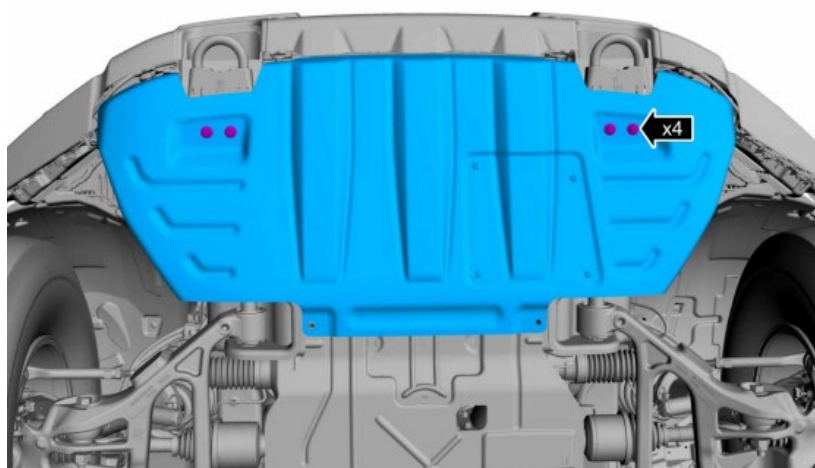

26. Install the underbody skid plate and spacer, secure with factory bolts. Torque to 41 ft-lbs.

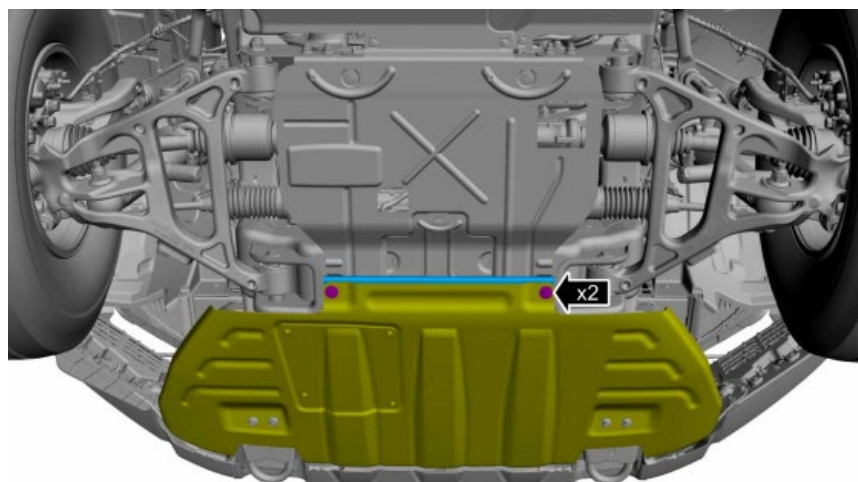

27. Disconnect the factory IAT sensor connector by squeezing the tab and pulling back away.

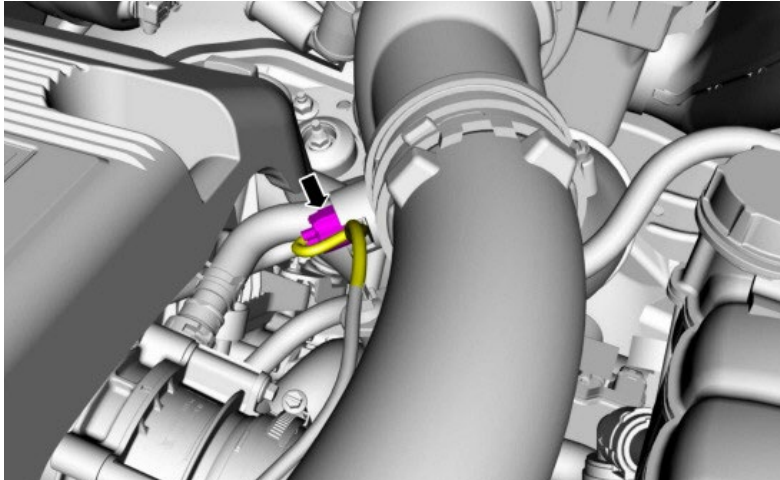

28. Loosen the (3) clamps from the factory air tube and remove the air tube from the engine.

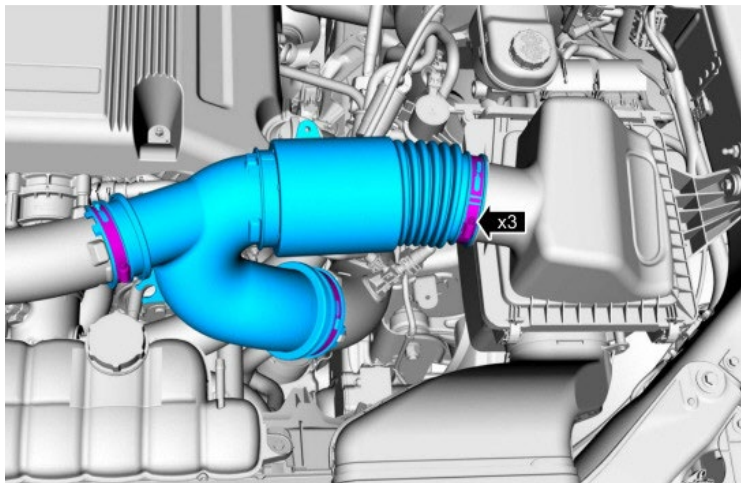

29. Unsnap the airbox retaining clips (2) and remove the factory filter, neither will be reused. Using a 10mm socket, remove the bolt securing airbox to body. Using a push pin removal tool, remove the 2 pins holding the airbox snorkel in place.

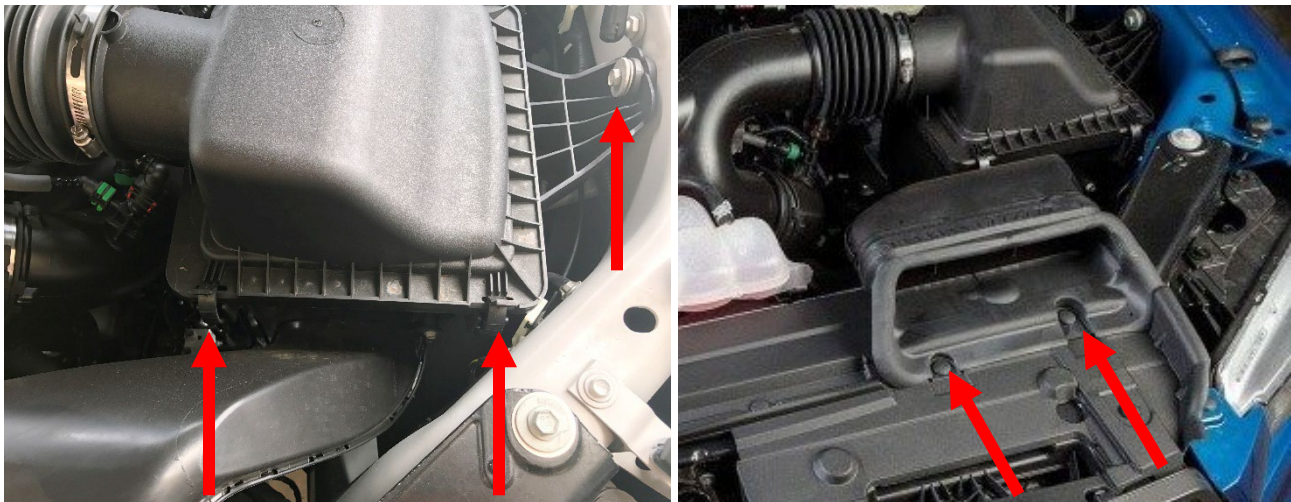

30. Install the lower airbox section to factory location. Using the supplied (2) 1" Christmas tree plastic tabs to snorkel section to secure airbox.

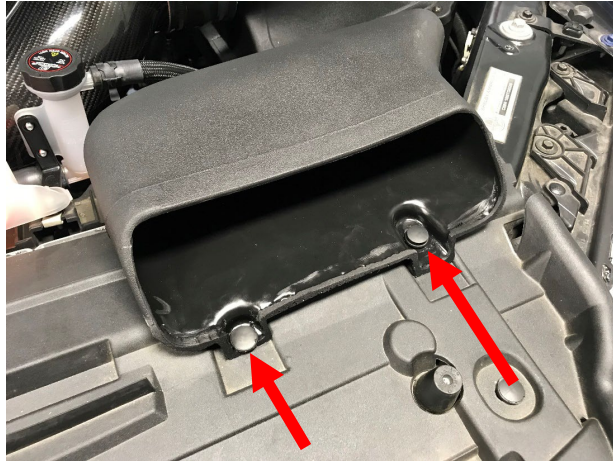

31. Install the supplied filter in the lower airbox. Install the supplied lid to filter and lower airbox. Secure using the supplied (6) 6mm x 16mm BHFCs. Torque to 50 in-lbs or snug. NOTE: Over torque can rip the brass insert out.

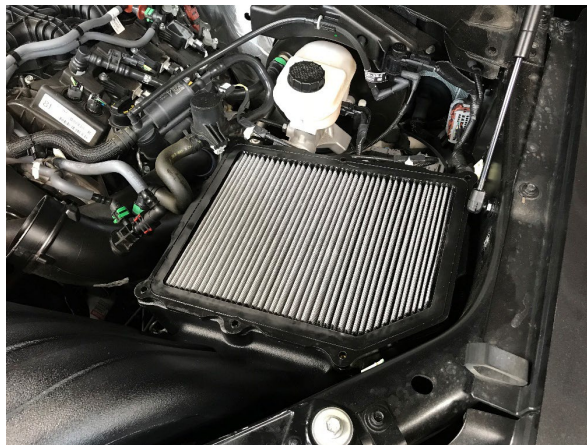

32. Remove the factory IAT sensor from the stock air tube by turning the sensor a ¼ turn, then lifting out of tube. Make sure the oring is still on the sensor and un-damaged.
33. Install the IAT sensor into the supplied plastic air temp sensor adapter. Install the rubber grommet into the Whipple air tube, apply grease to grommet, then install air temp sensor into grommet.



34. Install the supplied temp sensor adapter to air temp sensor. Install adapter and sensor into rubber grommet (apply light amount of engine oil or similar to help installation).

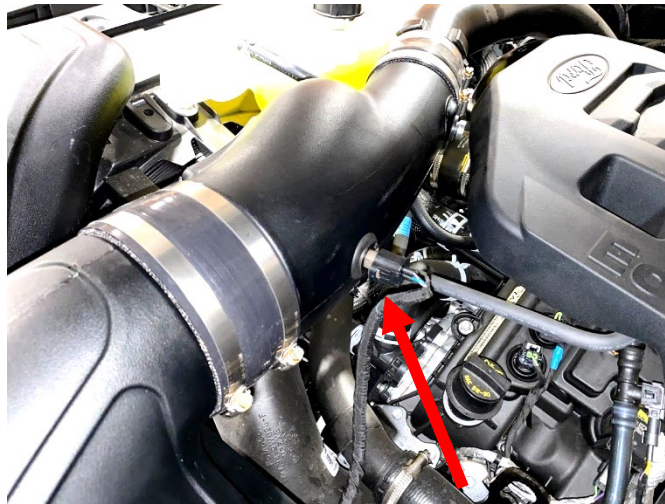

35. Install the supplied silicone hose to the Whipple air tube using the supplied clamps. Use the #64 clamp on the 4" hump hose and #56 on the 3.5" hose reducer hose. With all clamps semi-loose, center the airbox and air tube assembly for best fitment.



36. Remove factory spark plugs. Close the stock gap to .025" using spark plug adjustment tool. Failure to close the gap may result in horsepower variance and possible misfire. Apply light amount of anti-seize to threads. Torque to 133 in-lbs. NOTE: Never drop plugs into position, this can damage or change gap on plug.



37. Start the vehicle, check for any leaks or check engine lights.

IMPORTANT INFORMATION

BOOST LEVELS

All Whipple kits are shipped with boost levels that Whipple feels achieves maximum power while maintaining reliability with stock engines (@ sea level). Additional boost controllers cannot be added. Aftermarket wastegates are not supported.

EXHAUST

Cat-back exhaust systems help reduce heat and minimize exhaust back pressure. They do not affect the calibration and are always a good idea for added safety and performance. Long tube headers and/or high flow cats are not supported and are not legal by Whipple.

FUEL OCTANE

Never run a fuel octane that is below 91octane, $(RON+MON)/2$ and never run fuel with more volume than 10% Ethanol. It is recommended, when available, to run 92-94 octane. Never mix mid-level (below 91) with 91+, this is very dangerous and can cause severe engine damage. Do not attempt to increase octane ratings with generic octane boosters, these are very hard on spark plugs and many brands do very little to the actual octane rating (1 point is .1 octane). The PCM constantly adapts, if it senses better fuel, it will increase power accordingly.

Not all fuel is equal. Tier 1 type fuel such as Chevron, Shell, Unocal, Texaco, Sunoco, BP, Mobil, Phillips are highly recommended. Second rate "bargain" fuel from grocery stores and other vendors should always be avoided. Whipple testing has shown high risk when running premium fuel from places such as Costco, Vons, etc.