



**WHIPPLE SUPERCHARGER RAPTOR R 3.8L SC
INSTALLATION MANUAL**

2023-2024 FORD F150 RAPTOR R

PN: WK-2350-38, WK-2350-38-NFT



WHIPPLE SUPERCHARGERS

3292 NORTH WEBER AVE

FRESNO, CA 93722

TEL 559.442.1261

FAX 559.442.4153

WWW.WHIPPLESUPERCHARGERS.COM

PREMIUM FUEL ONLY (91 OCTANE OR BETTER ALWAYS) RON+MON/2

CALIFORNIA AIR RESOURCE BOARD EXECUTIVE ORDER #D231-99

INTRODUCTION

Before beginning installation, please read this manual and important notes:

- Please read the installation manual and verify that all items are present. If you are missing hardware or have any questions, please contact your dealer or Whipple Superchargers before you start the installation.
- Modifications to your Fascia and Grill can greatly affect performance. Other aftermarket parts may also create issues. The SC system is designed for stock vehicles.
- Premium fuel (US 91 octane) is required to prevent spark-knock/detonation under certain operating conditions. Other countries must meet US 91 octane standards, RON+MON/2. **If fuel of less than 91-octane is present in the vehicle fuel tank, the tank must be completely drained and refilled with 91 or higher octane to 1/8th of a tank. The fuel system is returnless, therefore, initial fuel in the system will be low octane. Drain all fuel!**
- Operating your engine without the Whipple Calibration can result in engine damage or failure and will void your warranty.
- Supply your VIN number (along with gear ratio, transmission type, throttle body type and any changes to vehicle) to Whipple ahead of time so your unique PCM calibration can be built prior to the SC installation to minimize any down time. **NOTE:** Whipple does not support long tube headers or cat removal. While the vehicle may run correctly, it will no longer be emissions legal and therefore not supported.
- **NEVER MANUALLY MOVE THE BYPASS ACTUATOR, YOU CAN RUPTURE THE INTERNAL DIAGHRAM.**

COMPETITION BASED PRODUCT MAY BE USED SOLELY ON VEHICLES USED IN SANCTIONED COMPETITION WHICH MAY NEVER BE USED UPON A PUBLIC ROAD OR HIGHWAY, UNLESS PERMITTED BY SPECIFIC REGULATORY EXEMPTION (VISIT THE "EMISSIONS" PAGE AT [HTTP://WWW.SEMASAN.COM/EMISSIONS](http://www.semasan.com/emissions) FOR STATE BY STATE DETAILS.

COMPETITION BASED PRODUCT IS LEGAL IN CALIFORNIA ONLY FOR RACING VEHICLES WHICH MAY NEVER BE USED, OR REGISTERED OR LICENSED FOR USE, UPON A HIGHWAY.

IT IS THE RESPONSIBILITY OF THE INSTALLER AND/OR USER OF THIS PRODUCT TO ENSURE THAT IT IS USED IN COMPLIANCE WITH ALL APPLICABLE LAWS AND REGULATIONS.

RECOMMENDED TOOLS AND SUPPLIES

The following items are not included in this supercharger kit and it is strongly recommended that they're used for ease of installation or maximum performance:

Tools

¼", 3/8" and ½" torque wrenches. Safety glasses, metric wrench set, ¼", 3/8", ½" assorted metric socket set, 5mm ball head allen, 3/8" assorted metric allen socket set, 8mm hex allen wrench, ½" breaker bar, flat head and Philips screw drivers and drain pan (for coolant). Heat gun or small torch for heat shrinking. Electric tape. Trim pad tool (for pushpin removal). Clean shop towels.

Tie Straps

These will be useful for securing the wiring harness away from the installation area as directed in the instruction manual. They are inexpensive and will be very handy during installation. You will need an assortment of 4", 8" and 12".

Sealants, Chemicals and Lubricants

Anti-seize for bolt and spark plug threads (use only when stated, otherwise the torque value must be reduced). Assembly lubricant (white lithium grease or petroleum jelly). Cleaner/degreaser such as carb cleaner. **Blue Loctite #243 or equivalent.**

You'll be required to fill your intercooler system with approx. 1.5 gallons of distilled water and Ford Factory specification engine coolant. This is not supplied in the system, you can find the coolant at any local auto parts store. **NEVER USE TAP WATER**, as it can corrode and create poor performance.

PRE-INSTALLATION CHECKLIST

Before installing your Whipple Supercharger Kit, complete the following checklist.

1. Vehicle Break-in: Brand new vehicles with sub 1000 miles should maintain OEM break-in procedures for the engine, clutch or transmission. Applying extra stress to the power-train before proper break-in is not recommended and could lead to damage which is not warrantable.
2. Verify Condition of Vehicle: Before the supercharger kit is installed, ensure the engine runs smoothly and that the factory malfunction indicator light (MIL) is off. Only install the supercharger kit if the engine runs smoothly *and* the MIL is off.
3. **!! CAUTION !!** This product is intended for use only on STOCK, UNMODIFIED, WELL-MAINTAINED vehicles and engines. Installation on a worn-out or modified engine is not recommended. Custom engine configurations are not supported, Whipple does not offer custom calibrations.
4. Verify Fuel System: Supercharger systems should only be installed on vehicles that have new or clean fuel filters.
5. Assess Cleanliness of Installation Area: Make sure your work area and the under-hood area are free from debris. This supercharger is a high-quality, close-tolerance compressor and must not be subjected to contamination by dirt or any type of foreign material. If necessary, vacuum around engine to remove any foreign material.
6. **!! CAUTION !!** DO NOT remove the protective seal on the supercharger prior to installation. Foreign material entering the supercharger will automatically void all warranties.
7. Identify Supercharger Kit Components: Before beginning installation, identify all the components of your Whipple Supercharger Kit and ensure all items are present and undamaged.
8. **!! CAUTION !!** Do not attempt to start the engine before adding the supplied Supercharger Oil to the supercharger!

SAFETY PRECAUTIONS



CAREFULLY READ THE IMPORTANT SAFETY PRECAUTIONS AND WARNINGS BEFORE PROCEEDING WITH THE INSTALLATION!

Appropriate disassembly, assembly methods and procedures are essential to ensure the personal safety of the individual performing the kit installation. Improper installation due to the failure to correctly follow these instructions could cause personally injury or death. Read each step of the installation manual carefully before starting the installation.

- Always wear safety glasses for eye protection.
- Place the ignition switch in the off position.
- Always apply the parking brake when working on vehicle.
- Block the front and rear tire surfaces to prevent unexpected vehicle movement.
- Operate the engine only in well-ventilated areas to avoid exposure to carbon monoxide.
- Do not smoke or use flammable items near or around fuel system.
- Use chemicals and cleaners only in well-ventilated areas.
- Batteries can produce explosive hydrogen gas which can cause personal injury. Do not allow flames, sparks or flammable sources to come near the battery.
- Keep hands and any other objects away from the radiator fan blades.
- Keep yourself and you're clothing away from moving parts when the engine is running.
- Do not wear loose clothing or jewelry that can be caught in rotating or moving parts.

GLOSSARY OF TERMS

ABBREVIATION	DESCRIPTION
ACT	Air Charger Temperature
DTC	Diagnostic Trouble Code
ECT	Engine Coolant Temperature
EGR	Exhaust Gas Recirculation
ETC	Electronic Throttle Control
EECPV	Electronic Evaporative emissions Canister Purge Valve
FHSCS	Flat Head Socket Cap Screw
IAT	Inlet Air Temperature
IC	Intercooler
ID	Internal Diameter
LB-IN	Pound-force inch
LB-FT	Pound-force foot
LTR	Low temp radiator
MAF	Mass Air Flow
MAP	Manifold Absolute Pressure
MY	Model Year
OBD	On Board Diagnostics
OD	Outside Diameter
PCV	Positive Crankcase Ventilation
PSI	Pound per Square Inch
SC	Supercharger
SHCS	Socket Head Cap Screw
TPS	Throttle Pressure Sensor
TRQ	Torque



****NOTICE:** Installation of Whipple Supercharger products signifies that you have read this document and have agreed to the terms stated within.

It's the purchaser's responsibility to follow all installation instruction guidelines and safety procedures supplied with the product as it's received by the purchaser to determine the compatibility of the product with the vehicle or the device the purchaser intends to install the product on.

Whipple Superchargers assumes no responsibility for damages occurring from accident, misuse, abuse, improper installation, improper operation, lack of reasonable care or all previously stated reasons resulting from incompatibility with other manufacturer's products.

There are no warranties expressed or implied for engine failure or damage to the vehicle in any way, loss of use or inconvenience or labor reimbursement. This includes merchantability and fitness.

The information contained in this publication was accurate and in effect at the time the publication was approved for printing and is subject to change without notice or liability. Whipple Superchargers reserves the right to revise the information presented herein or to discontinue the production of parts described at any time.

SUPERCHARGER INSTALLATION INSTRUCTIONS

It is strongly recommended that you read through this guide **BEFORE** you begin installing the Whipple Supercharger.

1. **BYPASS ACTUATOR:** This is pre-assembled and pre-installed. DO NOT MOVE the actuator, damage may occur.



2. (**Complete kits/Tomahawk tool**). Read the Tomahawk instructions supplied to extract the information required, always get your calibration before you start the install. The tool **IS NOT PRELOADED**.
3. Using an air hose, blow off any loose dirt or debris from engine compartment. If really dirty, then steam clean the engine compartment before proceeding to the next step.
4. Release the fuel system pressure (NOTE: The following procedure is taken directly from the Ford Service Manual).

WARNING ⚠️: Fuel in the system remains under high pressure even when the engine is not running. Before working on or disconnecting any of the fuel lines or fuel system components, the fuel system pressure must be relieved. Failure to do so can result in personal injury.

WARNING ⚠️: Do not smoke or carry lighted tobacco or open flame of any type when working on or near any fuel-related components. Highly flammable mixtures are always present and can be ignited, resulting in personal injury.

5. Disconnect the Fuel Pump Control Module electrical connector. This is located under the bed, near the spare tire. Disconnect the fuel pump driver module electrical connectors. Start the engine and allow it to idle until engine stalls. Turn the ignition to the off position.

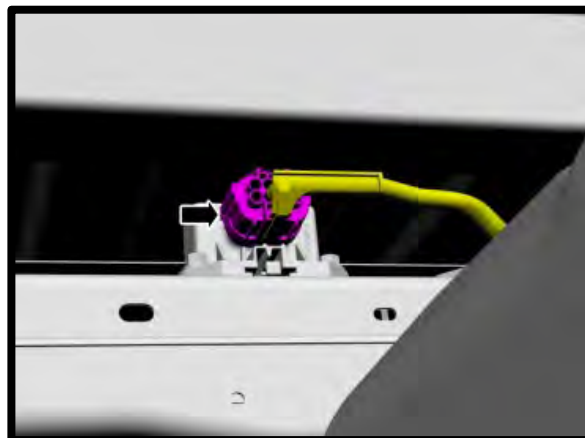

6. Locate the battery on the passenger side of vehicle. With an 10mm wrench disconnect the (-) negative battery cable. Make sure the cable is far enough away from the battery that it does not accidentally touch the battery and make connection during the installation.
7. Remove the (6) bolts from undershield and remove from vehicle. With a cool engine drain the coolant into a clean drain pan for reuse later. Remove the radiator cap to vent the system. (Be careful not to remove the radiator cap if the engine is still hot). The drain petcock is located on the bottom, driver side of radiator. Loosen spigot and let it drain into pan. Add a 3/8" ID hose to the end of the petcock for cleaner procedure.

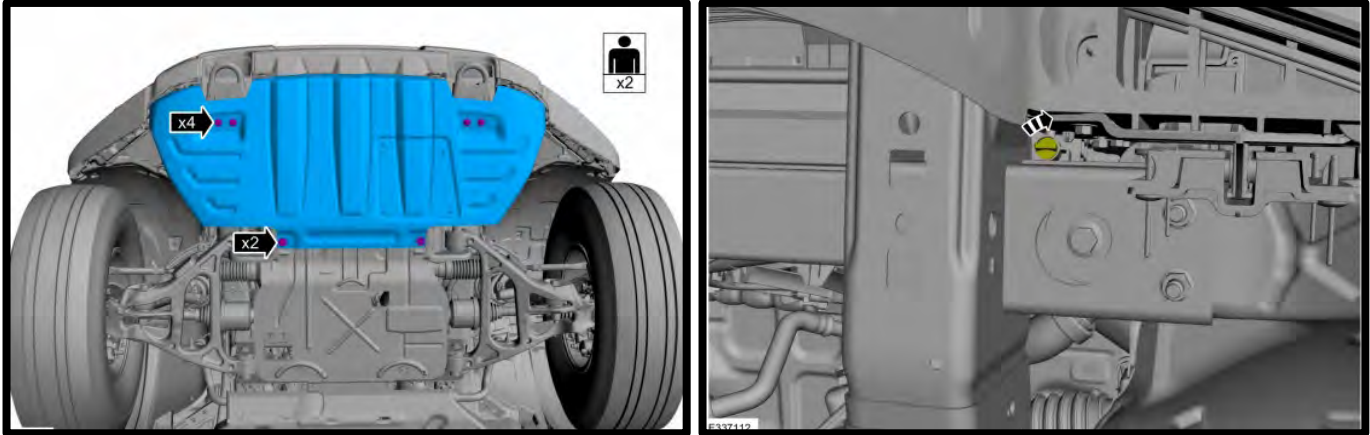

8. Detach the retainers from the air cleaner. Disconnect the IAT sensor electrical connector.

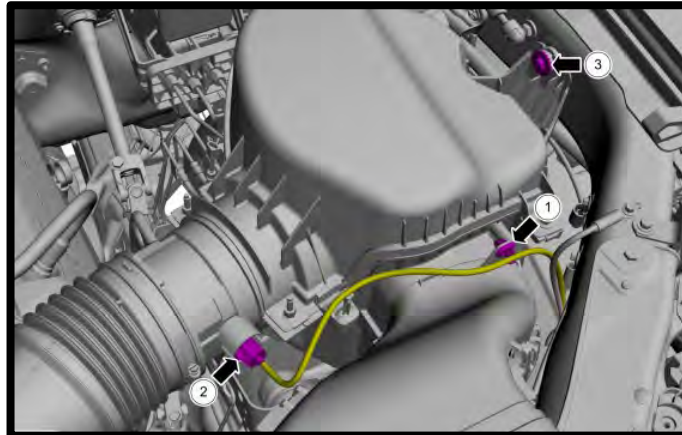

9. Disconnect the crank case vent tube and bypass vacuum line from inlet tube. Loosen clamp at throttle body. Remove the airbox mounting bolt and remove airbox assembly.

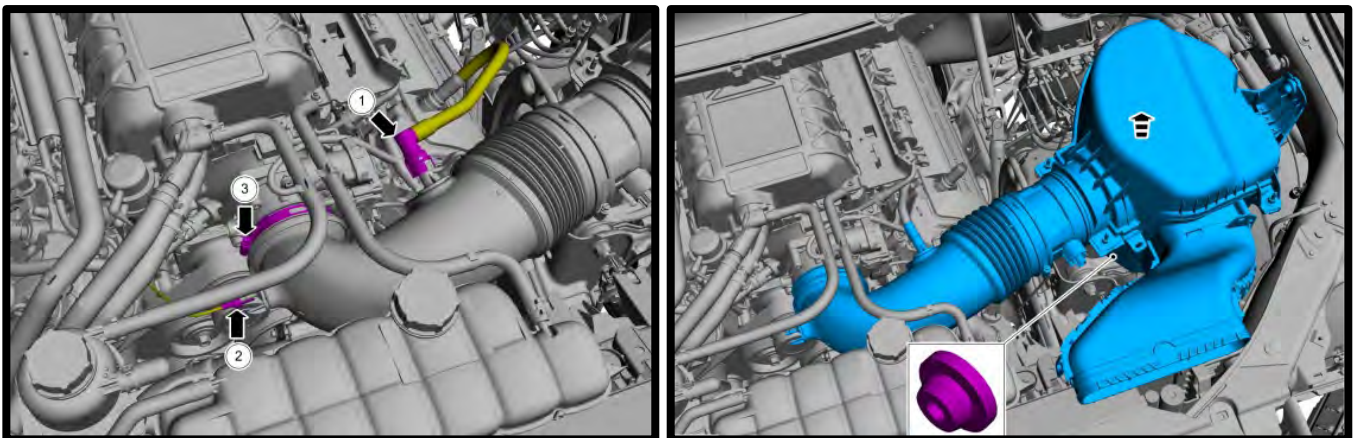

10. Disconnect throttle body electrical connector and coolant temp sensor, then detach the wire retainer.

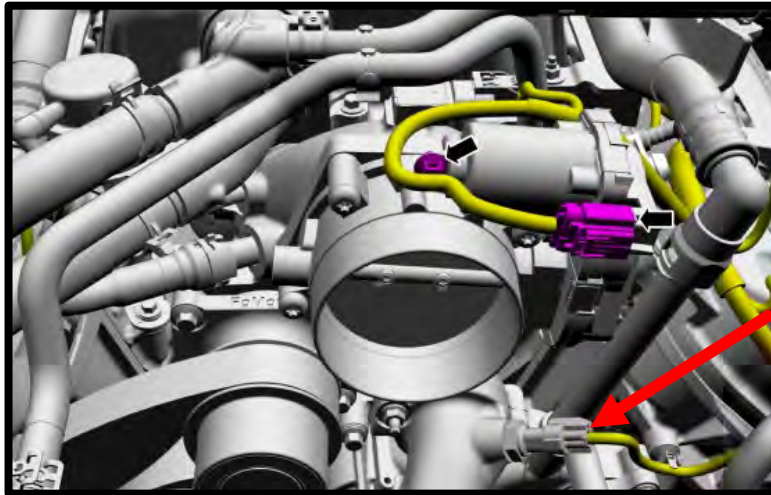

11. Disconnect the EVAP solenoid quick release coupling, release the valve from its bracket, then move out of the way.

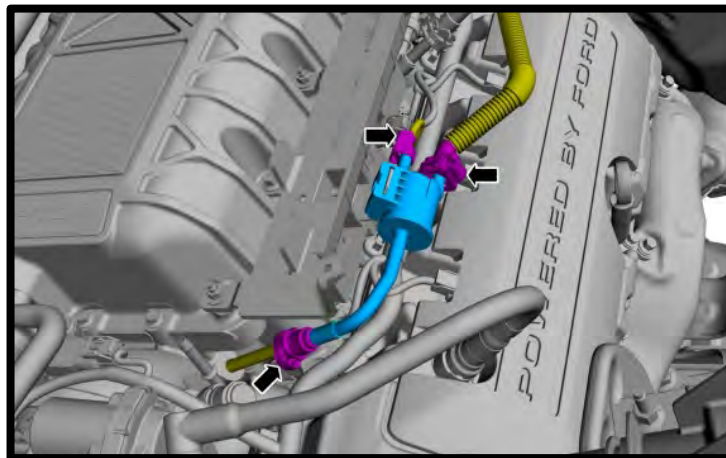

12. Mark each factory intercooler hose for future reference. Top is inlet, bottom is outlet. Remove both hoses from barbs and push aside.

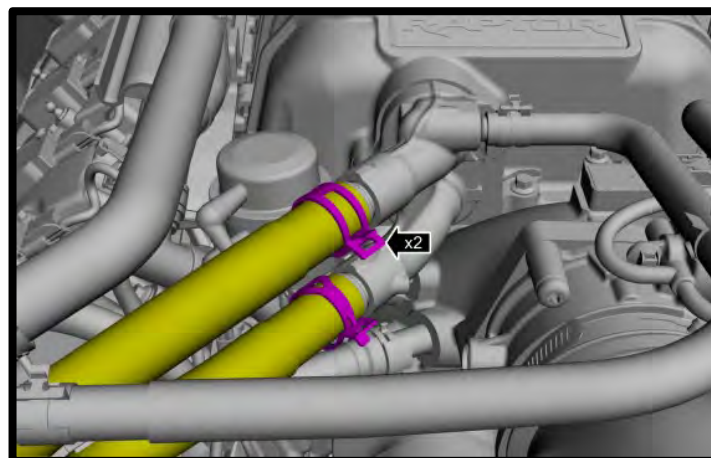

13. (1) Disconnect the hose clamps and the retainer, then position aside the hose. (2) Disconnect the supercharger cooling circuit hose clamps and retainers. These hoses will not be reused.

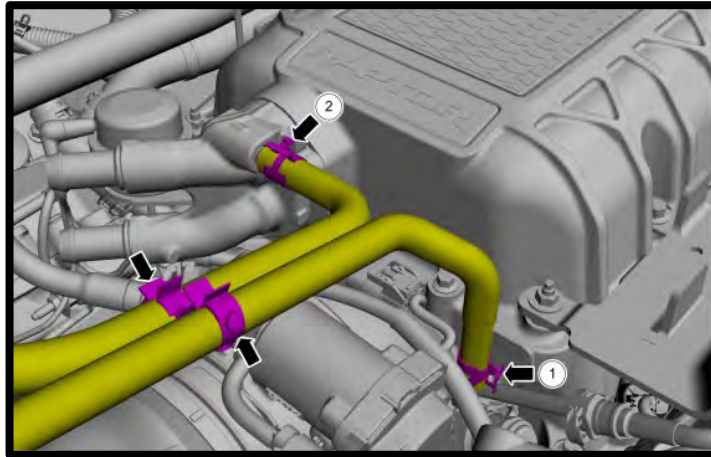

14. Disconnect the PCV line from RH valve cover and SC.

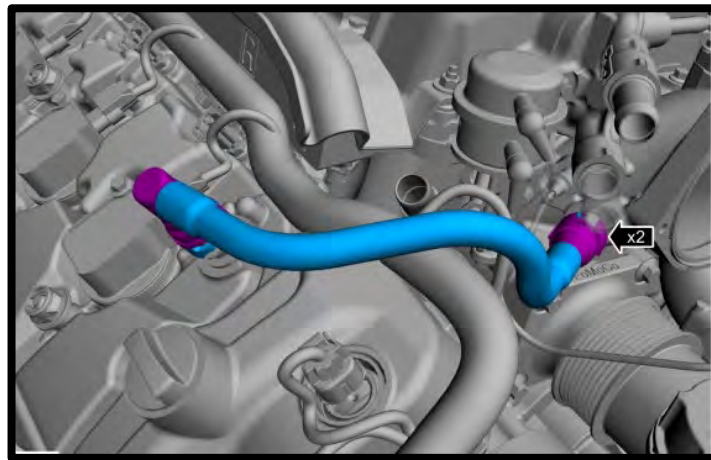

15. Cut and discard the OEM zip ties from radiator hoses. Detach retainer from coolant hoses from retainers. Detach quick connect fittings. Detach the LH and RH heater hose at the cowl panel and position hoses aside.

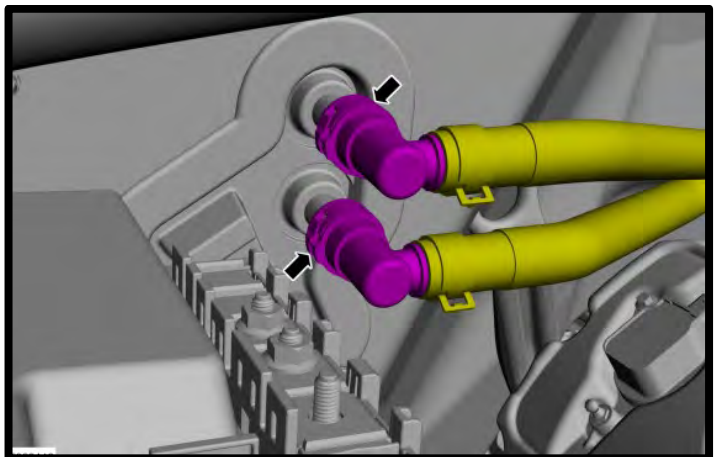
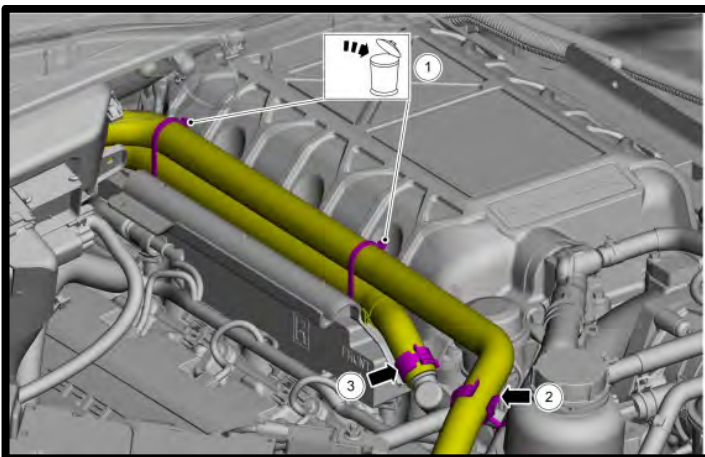

16. Remove the (6) nuts from SC lid, then remove the hose supports from both sides.

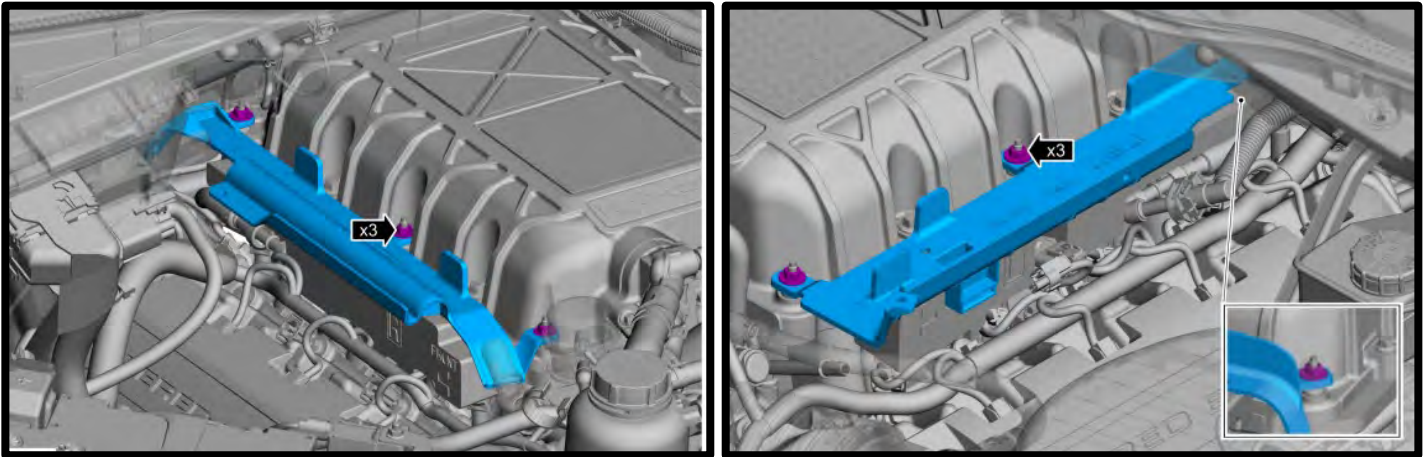

17. Remove the fuel rail insulator from both banks.

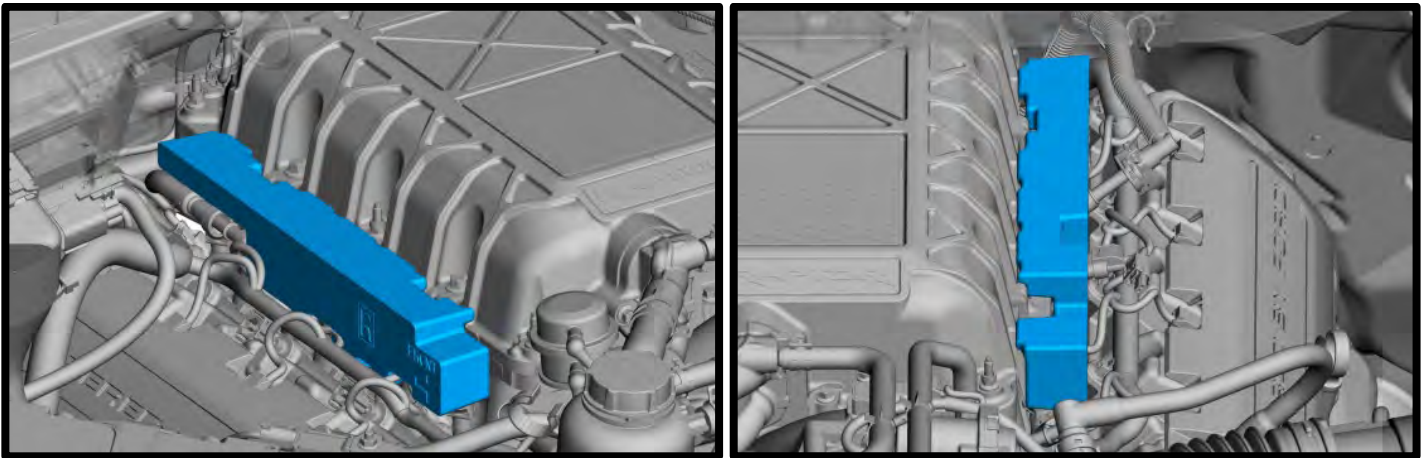

18. Disconnect all (8) fuel injectors and fuel pressure sensor electrical connectors.

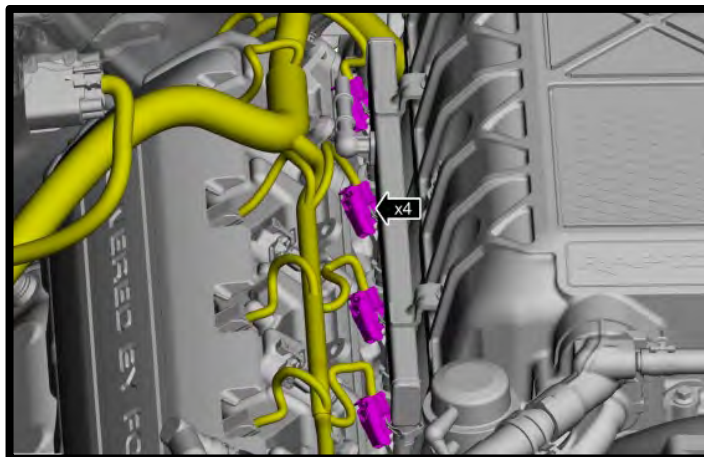

19. Disconnect the fuel supply quick release coupling from fuel rail. Disconnect the fuel rail cross over hose using a 3/8" fuel line removal tool.

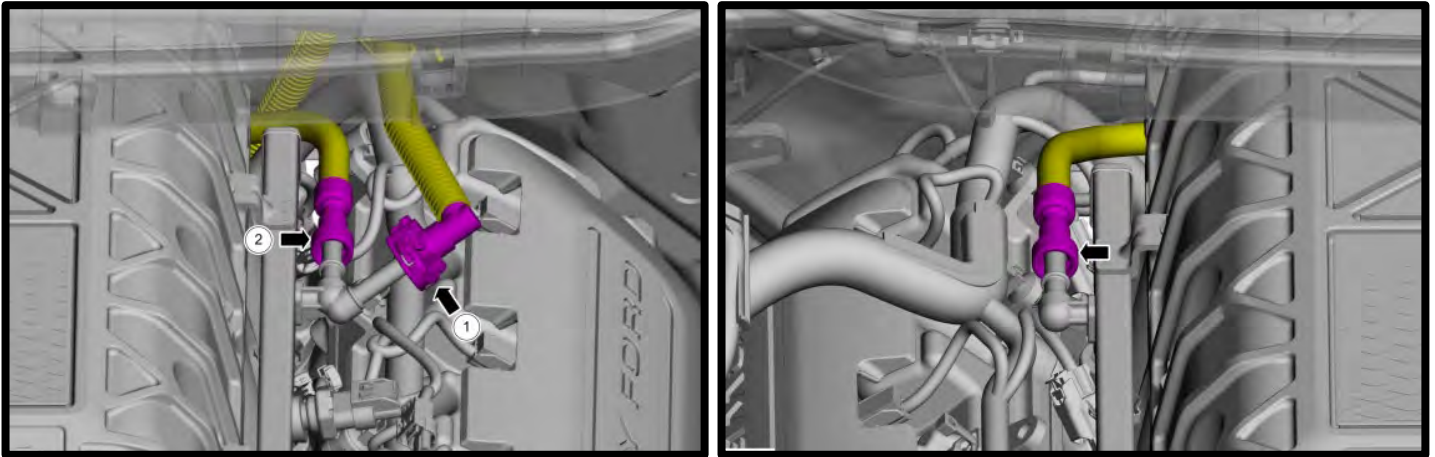

20. Detach the retainer securing fuel line to SC assembly, then remove fuel line from engine.

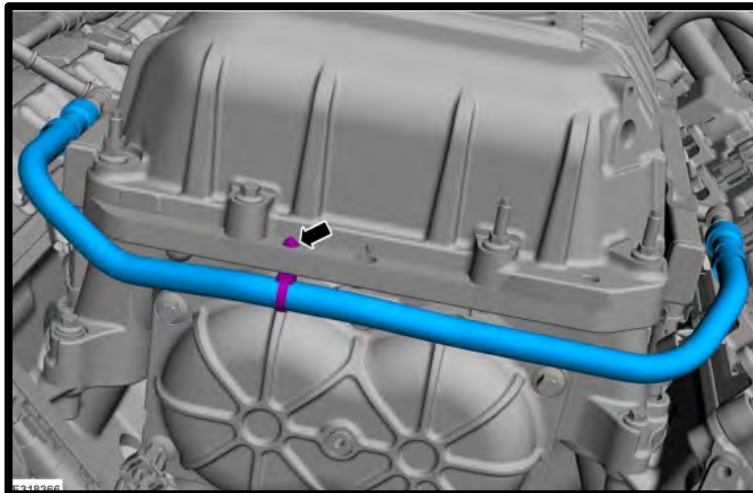

21. Remove the supercharger from engine by removing the (6) supercharger assembly bolts and (4) bolts from fuel rails (10mm socket).

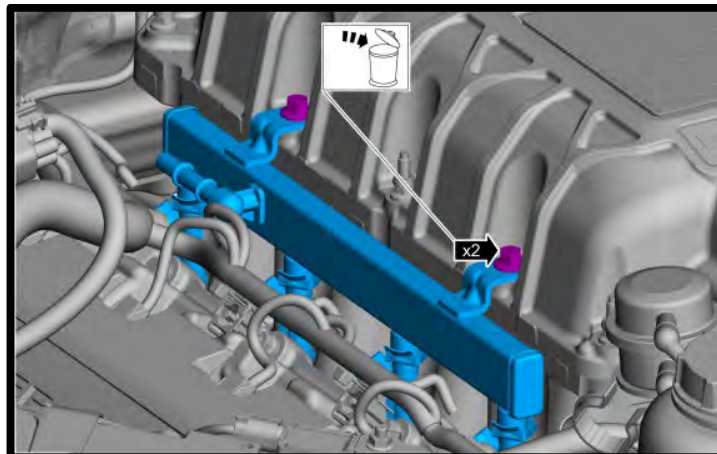

22. Detach wiring harness retainers (3) from SC assembly and push aside. **NOTE: Failure to do so here may result in pulling crank sensor harness and connector out of sensor. If struggling with harness, disconnect crank sensor temporarily, this allows you to pull SC further forward during removal. Reconnect sensor when done.**

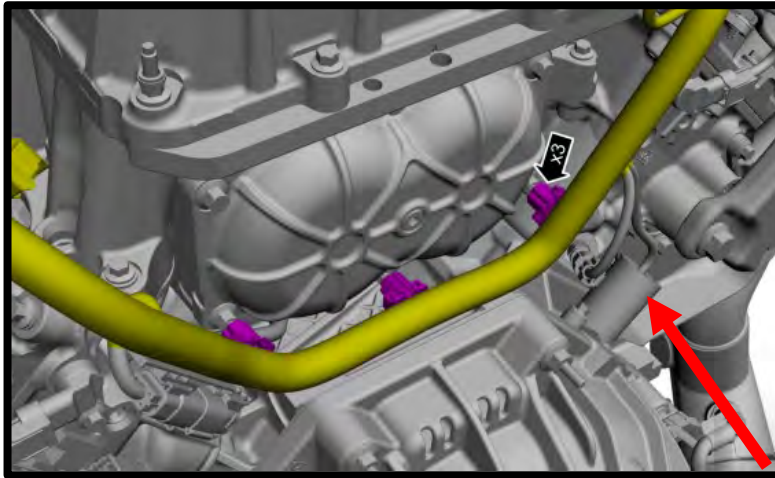

23. Disconnect the TMAP sensor from supercharger lid and TMAP (SIP) sensor from supercharger inlet. Remove both sensors from supercharger assembly for installation to new supercharger. **NOTE: Do not mix up sensors.**

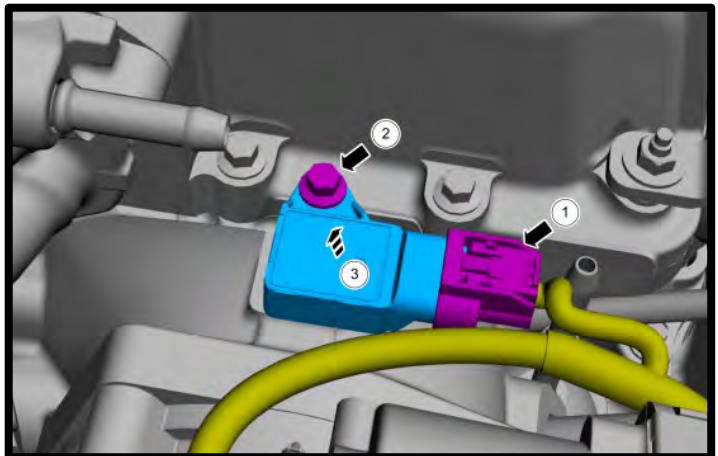
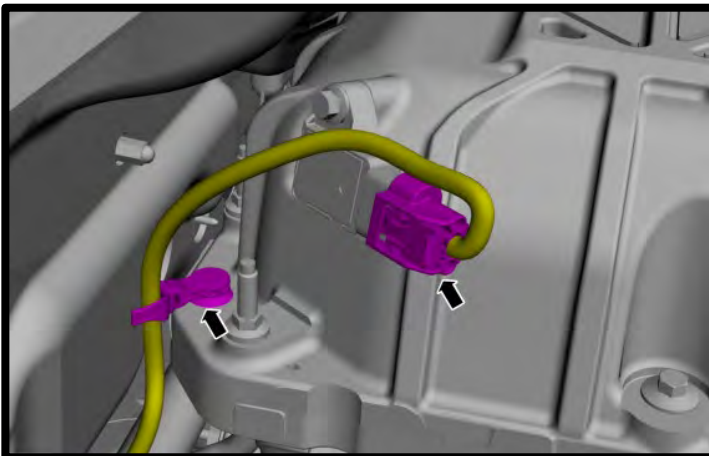

24. Remove the clamp from the LH heater tube. Remove hose from engine.

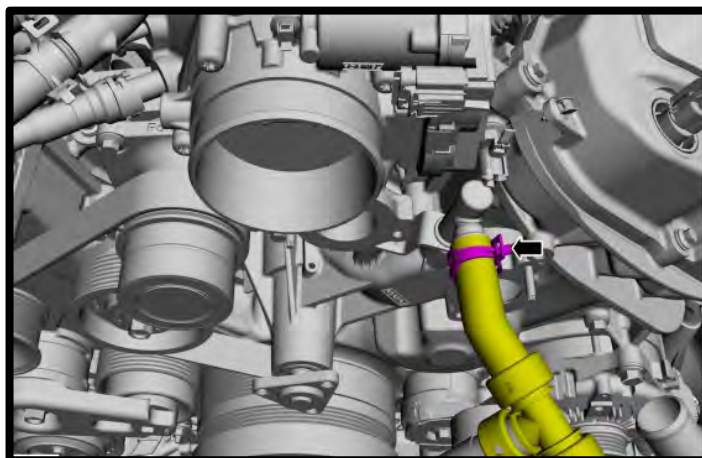

25. Disconnect RH heater quick connect fitting from water neck. Remove the heater tube from the engine.

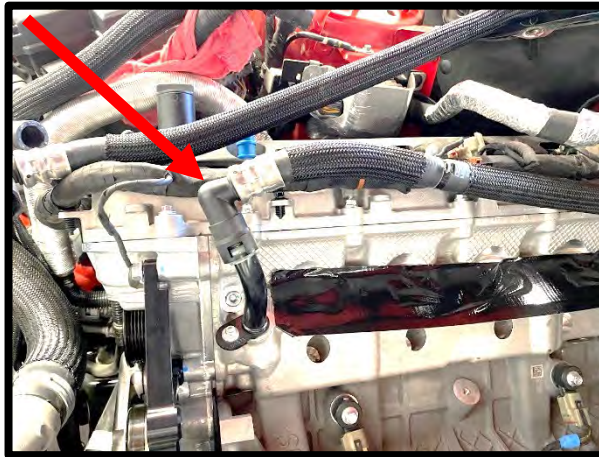

26. Remove factory ground wire by removing nut, using 10mm wrench. Relocate to valve cover bolt. Torque to 89 in-lbs.

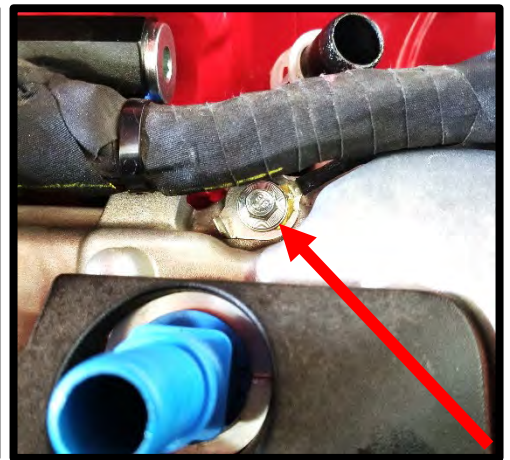
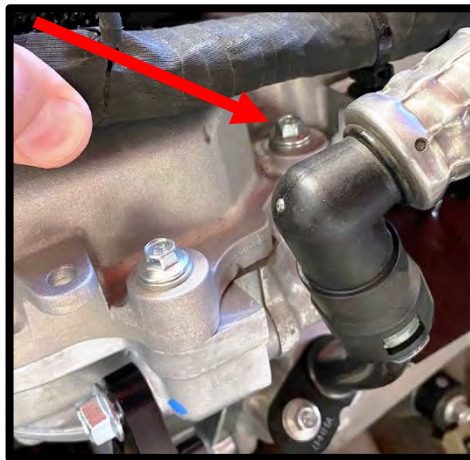
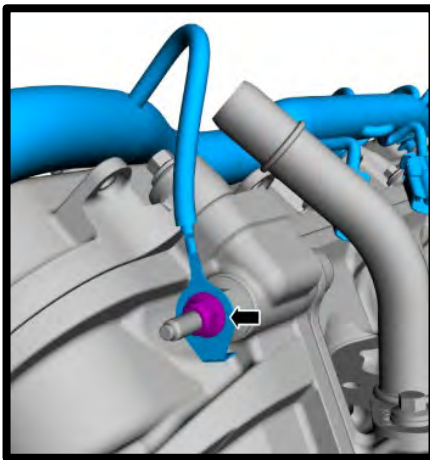

27. Install the #2-113 oring to the supplied heater tube and apply light amount of grease to oring. Install the heater tube to engine and secure using the supplied fork and stock fastener. Torque to 89 lbs-in.



28. Move the clamp back from RH heater hose fitting. Cut approximately 1 ½" from end of hose as shown.



29. Install the ¾" hose coupler to the stock heater hose. Install supplied molded hose with the 90deg bend to ¾" barb. Slide 2 shrink clamps around hose/coupler. Test fit hose to heater tube previously installed. Once hose is verified, use heat gun to shrink clamps at coupler. Use supplied #16 worm clamp to secure heater hose to heater tube.



30. Loosen the coolant pump pulley bolts (10mm socket).

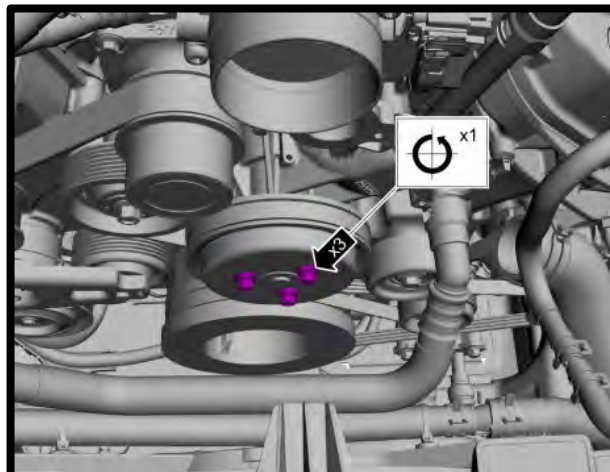

31. Rotate the accessory drive belt tensioner counterclockwise and remove belt. Rotate the supercharger belt tensioner clockwise and remove supercharger belt. Remove belt from engine.

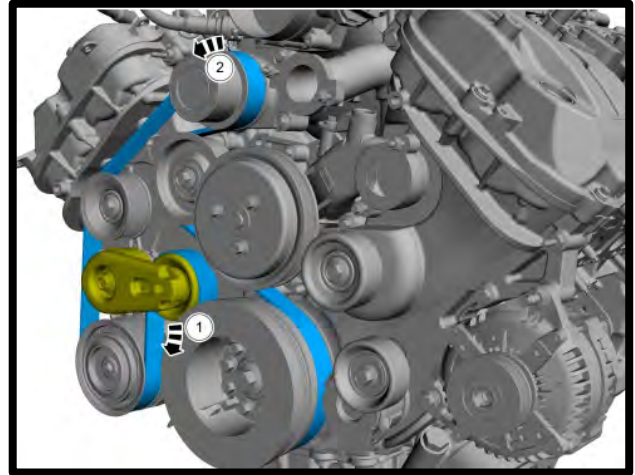
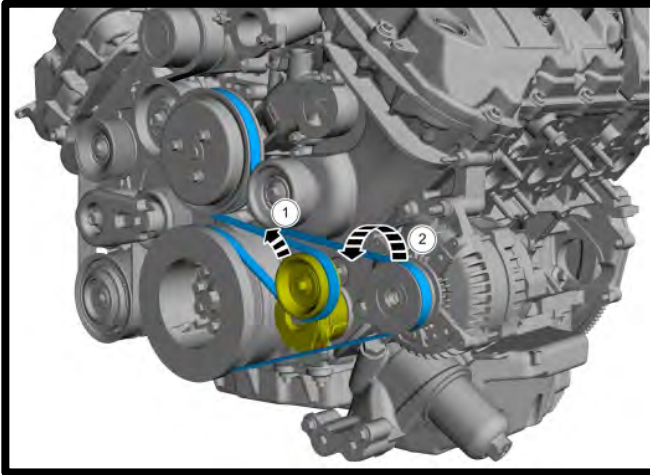

32. Remove the (3) water pump pulley bolts and water pump pulley (10mm socket).

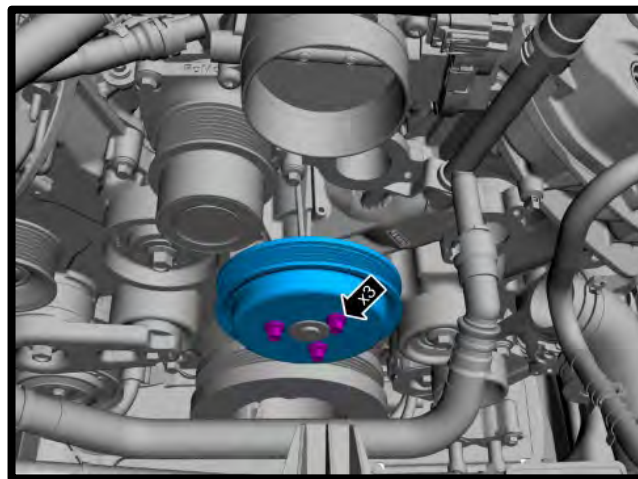

33. Remove stock idler pulley from engine using a 15mm socket. Using 13mm socket, remove the stud from timing cover. Using 10mm socket, remove the (2) stock bolts from timing cover and water pump.

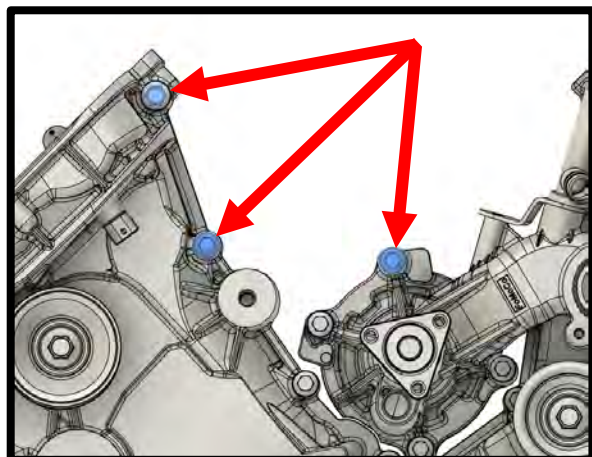

34. Install idler plate to engine using the (1) 8mm x 65mm HHFCS, (1) 8mm x 60mm SHCS and (1) 8mm x 55mm SHCS bolts to secure to timing chain cover. **Leave loose for now.**

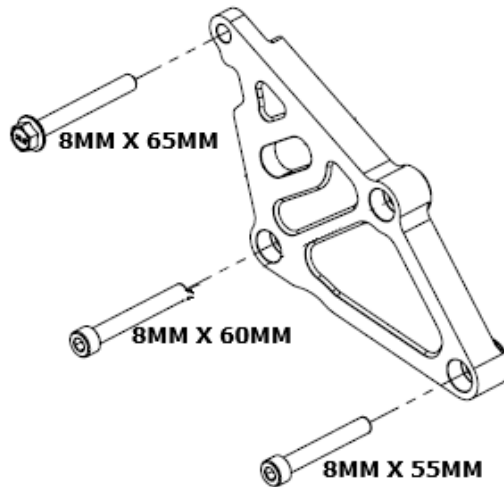

35. Install the supplied **70mm** OD billet idler pulley to the stock idler location previously removed, use the 10mm x 50mm HHFCS, 10mm step washer and **.390"** step spacer. Torque to 35 lbs-ft. **NOTE:** Snap ring faces towards engine.

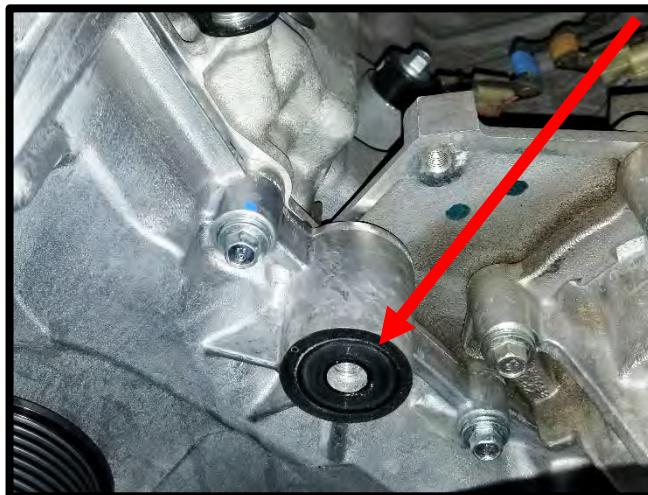
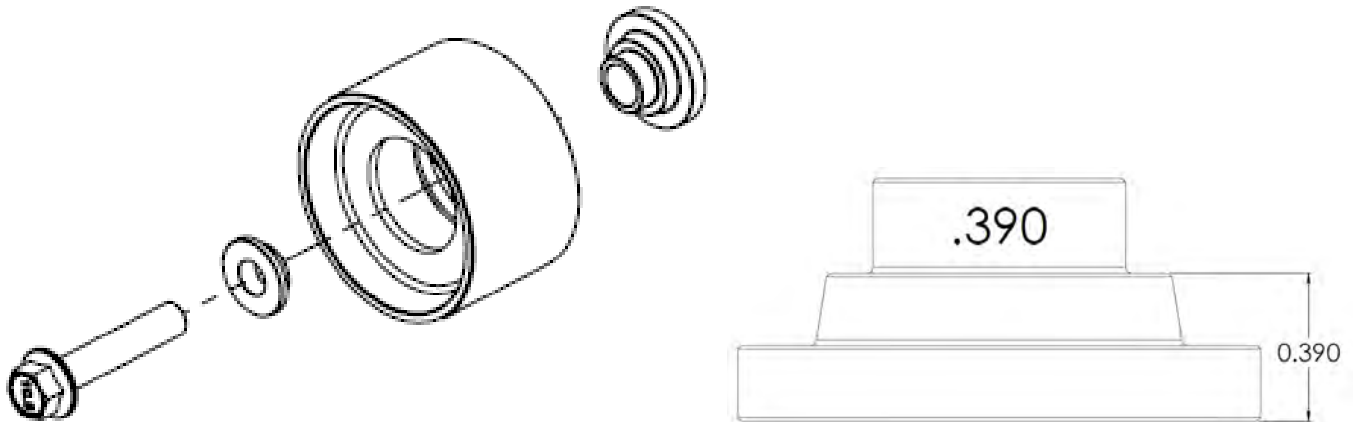

36. Remove water neck from engine by removing the (4) fasteners, this will not be reused. Remove oring from water neck, transfer to new supplied water neck.

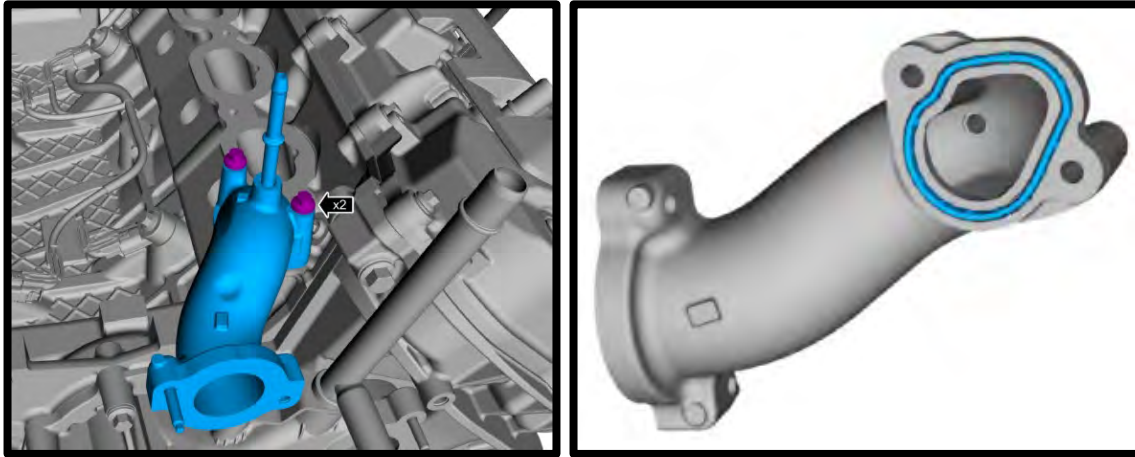

37. Install new water neck into stock location. Secure to cylinder head using the (1) 6mm x 30mm and (1) 6mm x 50mm SHCS. Secure to stock thermostat housing using factory fasteners. Get all parts hand tight before torquing. Torque the (2) nuts to 89 in-lbs first. Follow by torquing stock water neck bolts to 89 in-lbs.

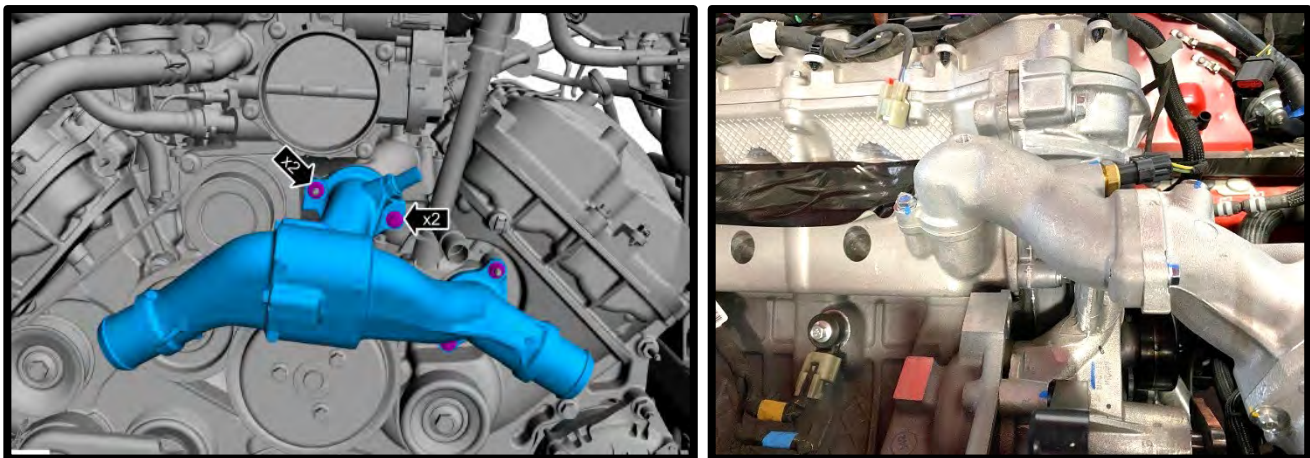

38. Apply light amount of thread sealant to threads of supplied 1/8" NPT to 5/16" fitting. Install fitting into new water neck, rotate to face LH side of engine.

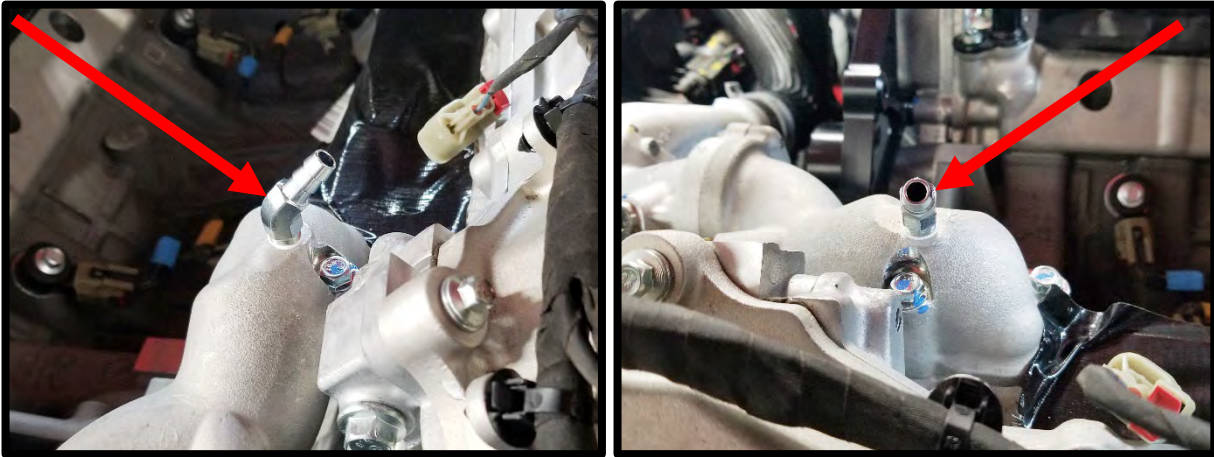

39. Preinstall stock vent hose to the 45deg fitting in water neck, secure using stock clamp. NOTE: This will later be routed to engine degas bottle.

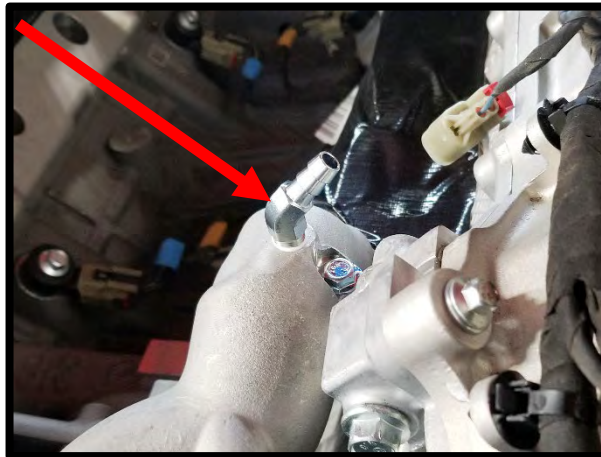

40. Remove stock coolant temp sensor from factory thermostat housing. Install supplied plug to factory location. Install coolant temp sensor in new water neck (needed for throttle body clearance).

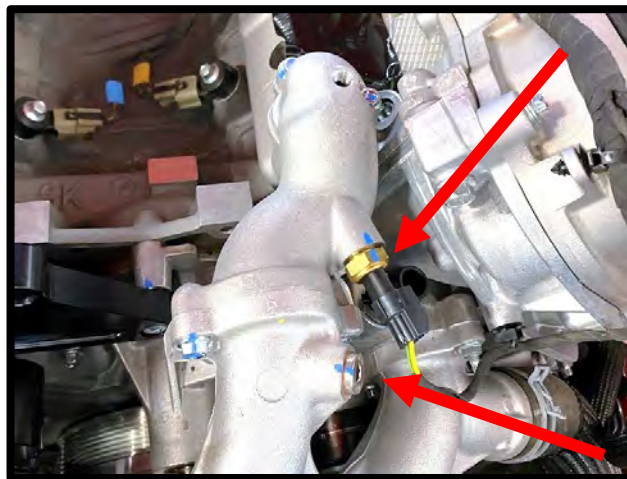

41. Install sliding tee-nut to back side of bracket (**NOTE:** Tee nut is directional to use as extra adjustment, stock setups need to use it as shown, closest to lower pulley). Install **65mm** billet idler pulley to plate using the $\frac{1}{2}$ " step washer and **.500"** step spacer. Secure using $\frac{1}{2}$ " x 2" HHFCS and step washer. Leave hand tight for now.

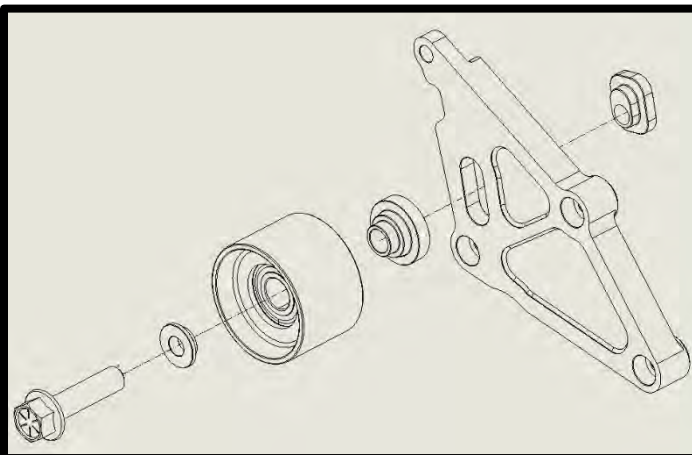
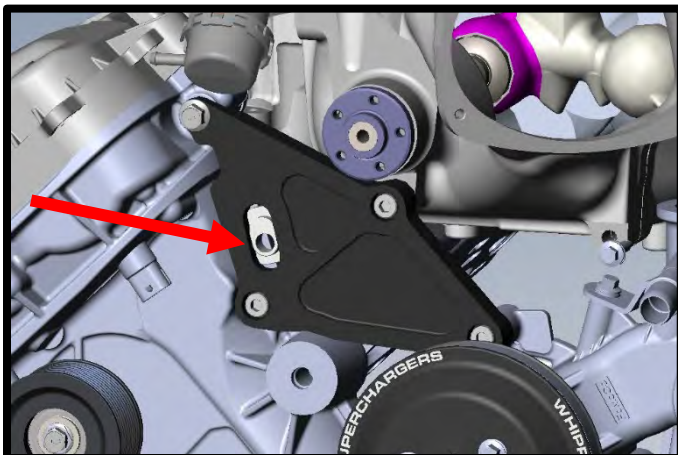

42. Using a 10mm socket, remove the (4) 6mm flanged hex bolts securing the supercharger lid to housing. Remove the lid from the housing. Set the lid and intercooler assembly on a padded surface so no damage can occur to intercooler cores.
43. Using the previously removed stock TMAP sensor, install to the front of the intake manifold using the supplied (1) 6mm x 20mm SHCS with the (1) 6mm AN washer with light amount of **Blue Loctite #243** to the threads. Apply generous amount of grease to the rubber oring for easy installation. Torque to 65 in-lb. Install TMAP extension harness to sensor for later connection to stock connector.

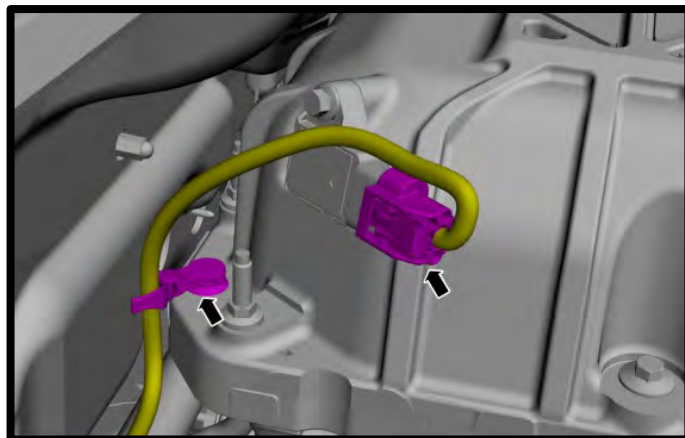

44. Install the supplied TMAP pigtail to the 3-Bar TMAP supplied, wrap up to SC inlet as this will get connected to stock harness later.

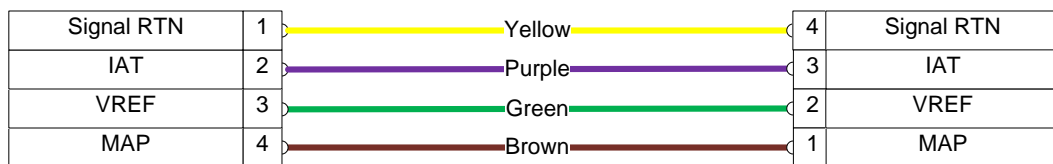

Male plugs into
FACTORY HARNESS SIDE



MAP Connector to plug
into sensor shown

45. Inspect OEM wiring harness at the rear of the engine, including crank sensor (rear, RH side) to ensure no damage was done during disassembly.
46. Install supplied 1/8" and 3/8" NPT plugs to back of SC, using light amount of pipe sealant on threads.

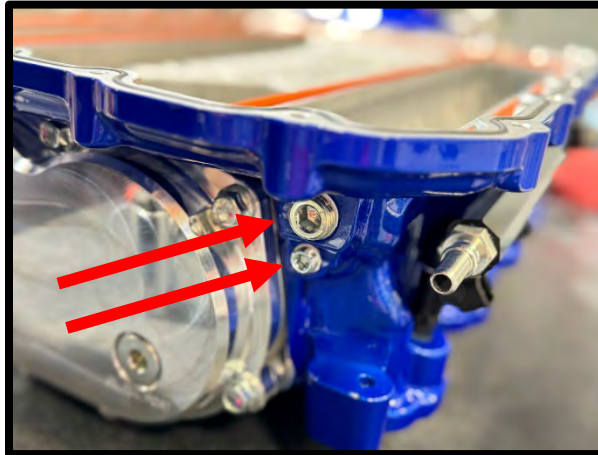

47. Install the supplied (8) manifold orings to the Whipple intake manifold to cylinder head surface, apply light amount of grease to ease installation.



48. Make sure the supercharger is on a flat surface. Remove the oil fill plug using an 8mm allen socket.
- Fill the compressor to the **MIDDLE** of the sight glass (**5.8 FL/OZ**). Rock compressor back and forth. Then spin the compressor/rotors by the pulley so the oil fills the bearings. **NEVER OVER FILL THE SUPERCHARGER!**
 - Apply light amount of grease to oil fill plug oring, reinstall. Torque to 140 lbs-in.

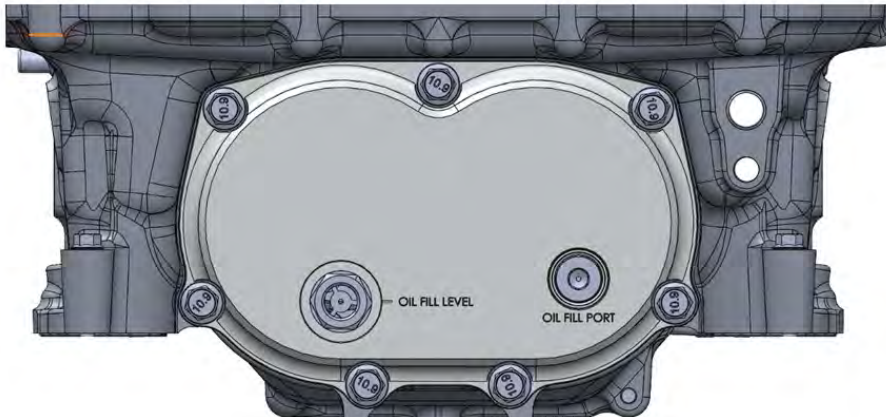

49. Install the supercharger housing (without lid) to the engine. Use the supplied (4) 6mm x 45mm HHFCS on the outer bolt holes and the (6) 6mm x 75mm HHFCS bolts with the supplied (6) #2-009 orings on the bolt, under the head. Use **Blue Loctite #243** on the threads of each bolt. Leave hand tight for now.



50. Install supplied (1) 8mm x 25mm SHCS through the front plate and supercharger inlet. Torque all (4) mounting bolts for plate to 72 in-lbs to help pull SC forward (finish torquing after SC to head torque sequence).

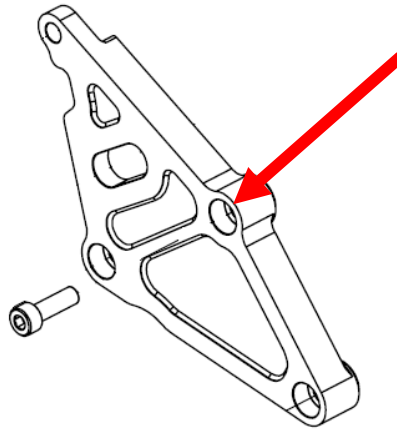

51. Torque the (10) 6mm HHFCS manifold bolts in the following pattern using a 10mm socket. First pass: 88 lbs-in. Second pass: 106 lb-in. **NOTE:** For bolt #10, a 1/4" socket with 4"-6" extension, 10mm wobble is the best possible tool to get into this tight area.

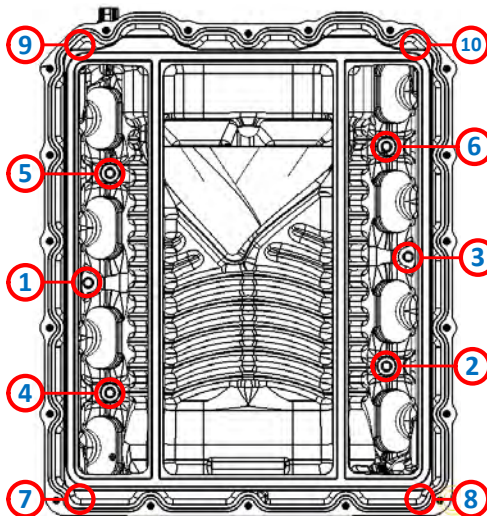

52. Torque the (3) idler plate bolts that secure plate to timing cover and plate to inlet, to 21 ft-lb. Torque the (1) 8mm x 55mm SHCS bolt to water pump to 180 in-lb.

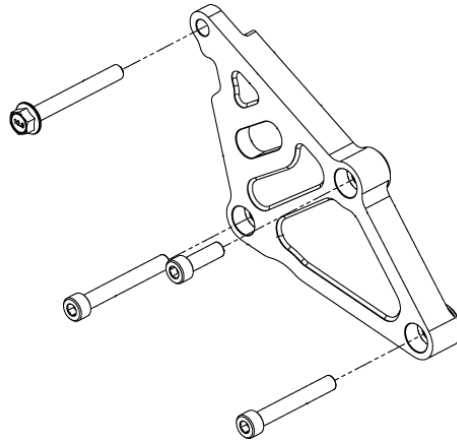

53. Remove the (8x) safety clips from injectors. Remove the injectors from fuel rail. Remove the top and bottom orings from stock injectors. Use Berryman B-12 Carburetor cleaner to clean orings or soak orings for a couple hours in a cleaner such as 409 or similar. If orings have any cuts or damage, replace prior to installing. Once clean, reinstall orings to stock fuel injectors.

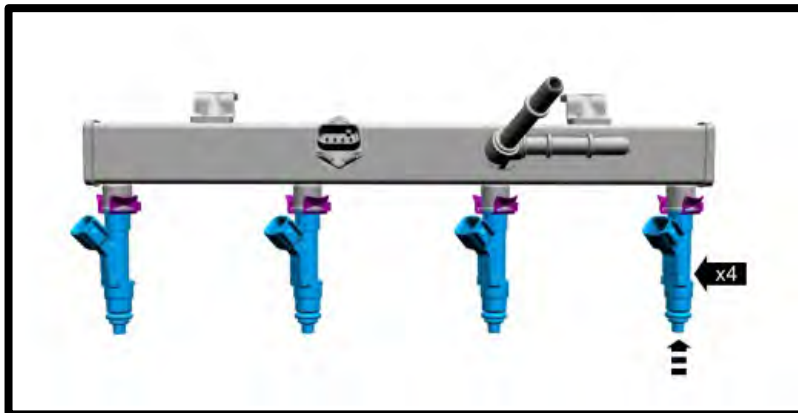

54. Using a 24mm socket, remove the fuel PSI sensor from the factory fuel rail. Using a 24mm socket, remove the fuel PSI sensor from the factory fuel rail. Install the factory fuel PSI sensor to the fuel rail using a 24mm socket. Torque to 53 lbs-in, then an additional 25-degree rotation. **NOTE: No sealant on the threads.** Connect factory electrical connector to sensor.

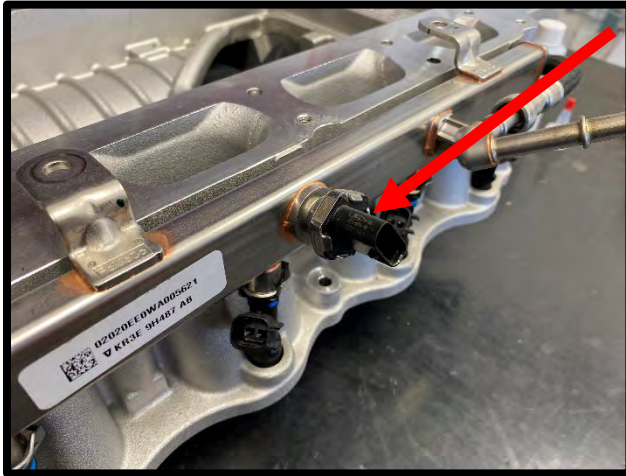

55. Install the (2x) #2-908 Viton oring to the (2x) -8 ORB to 8 AN plugs, install in front side of fuel rails.

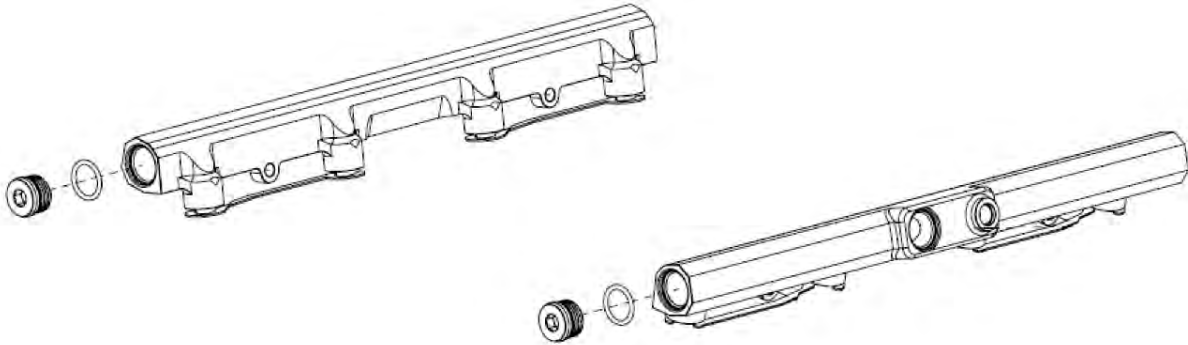

56. Install the supplied (2x) #2-908 Viton oring to the (2) -8 ORB to 12.61mm fittings. Apply light amount of grease to oring for ease of installation. Install fittings into rear fuel rail ports.

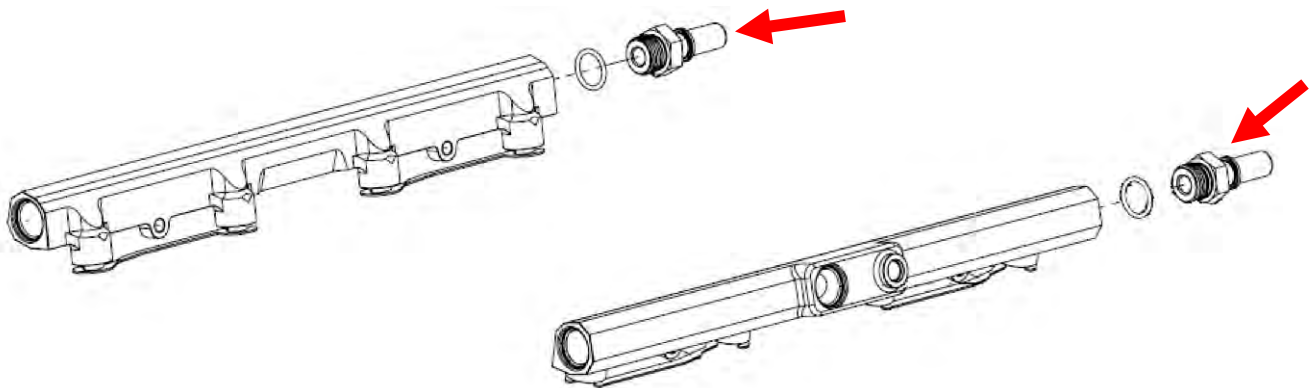

57. Install the supplied (4x) fuel injector position lock brackets to clock the fuel injectors into proper position. While installing the lock brackets, secure the fuel injector so it does not add pressure to the injector body. **Note:** This is for dual spray pattern injectors only that must be at the correct angle. **TIP: Failure to clock the injector correctly can cause severe running issues and motor failure.**

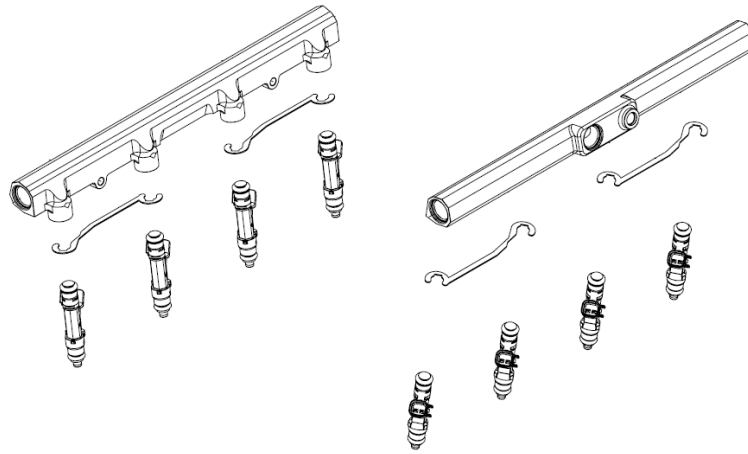

58. Apply generous amount of grease to the injector orings for ease of installation. Install the fuel injectors, rails and lock bracket to the intake manifold, secure with the (4x) 6mm x 16mm SHCS using a 5mm allen socket. Use **Blue Loctite #243** on the threads of each bolt. Torque to 90 lbs-in.

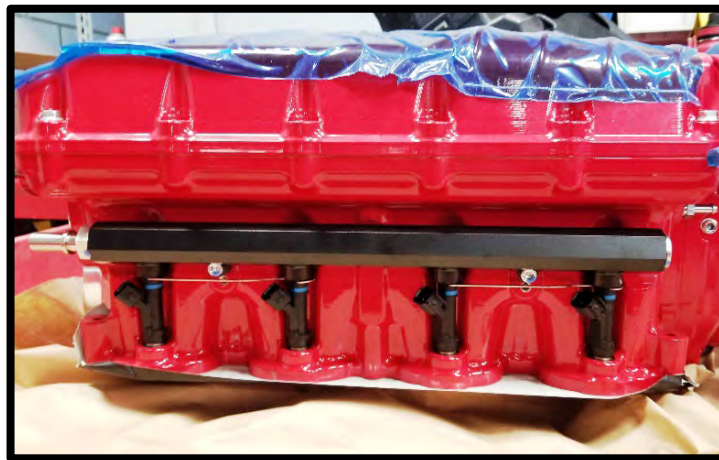

59. Install the supplied 1/2" fuel cross over line around the back of the supercharger by pressing until they click and lock in place.

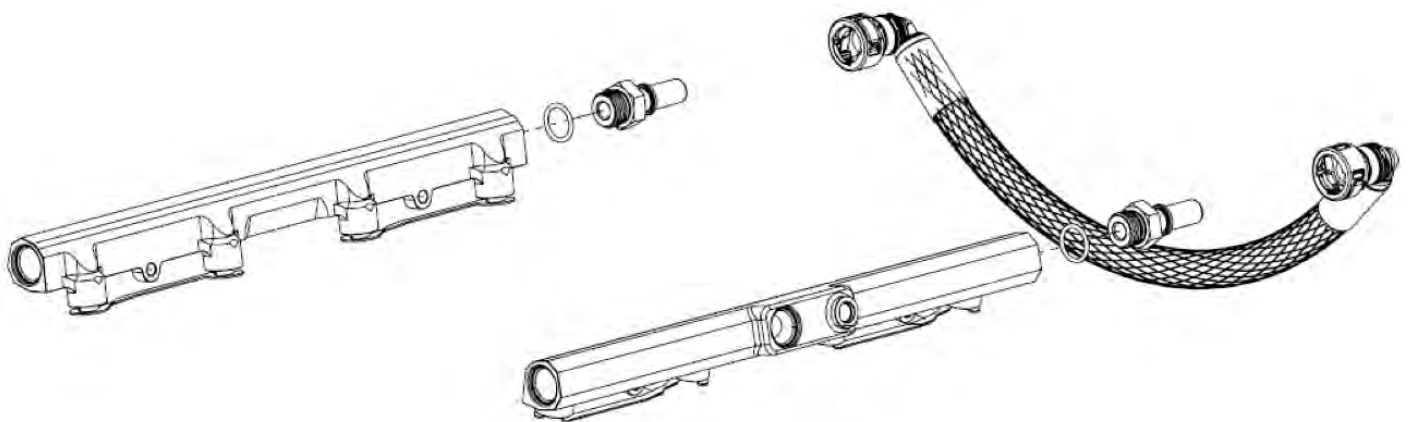

60. Install the supplied (1x) #2-906 Viton oring to the 45mm long -8 ORB to 9.49mm inlet fitting next to fuel PSI sensor. Apply light amount of grease to oring for ease of installation.

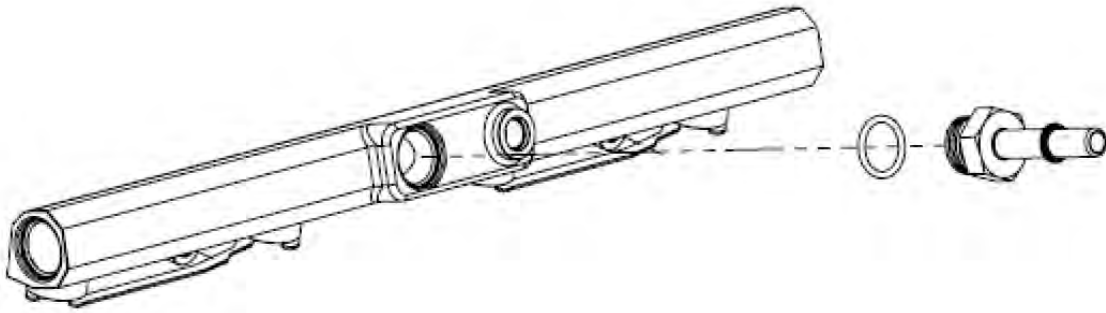

61. Connect stock feed hose to newly installed 9.49mm fitting. Reconnect fuel PSI electrical connector.
62. Reinstall the (3x) water pump pulley bolts and water pump pulley, torque to 18 ft-lb.

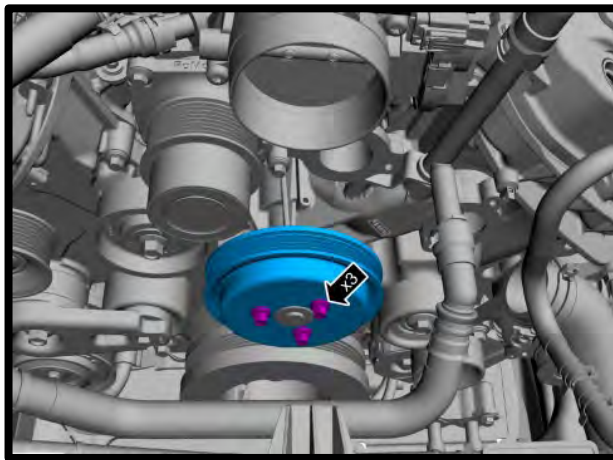

63. Reinstall stock accessory belt by releasing tension on spring loaded tensioner.

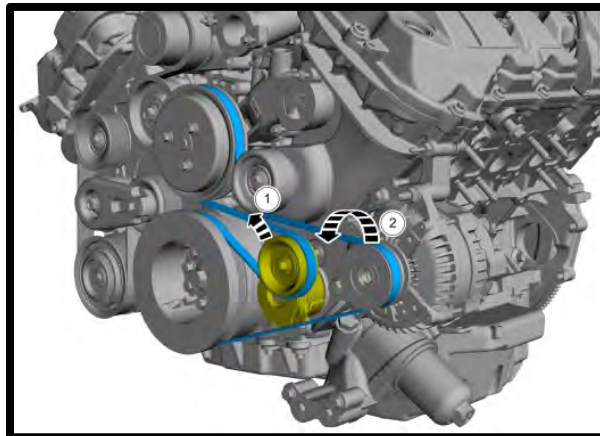

64. Install the supercharger pulley using the supplied (5x) 6mm x 14mm SHCS using a 5mm allen socket. **Leave hand tight until after belt installation.** Install the supplied supercharger belt by following the routing diagram. The spring-loaded tensioner should be 100% full open. Once in position, lock the adjustable idler pulley by torquing the

SHCS to 30 lbs-ft. **NOTE:** If using Whipple tensioner position so the arrow points to **100** (80%-85% travel) by removing slack via the adjustable idler pulley. If tensioner doesn't have enough travel, then tensioner will hit its stop during max stretch and the belt will slip, break or jump.

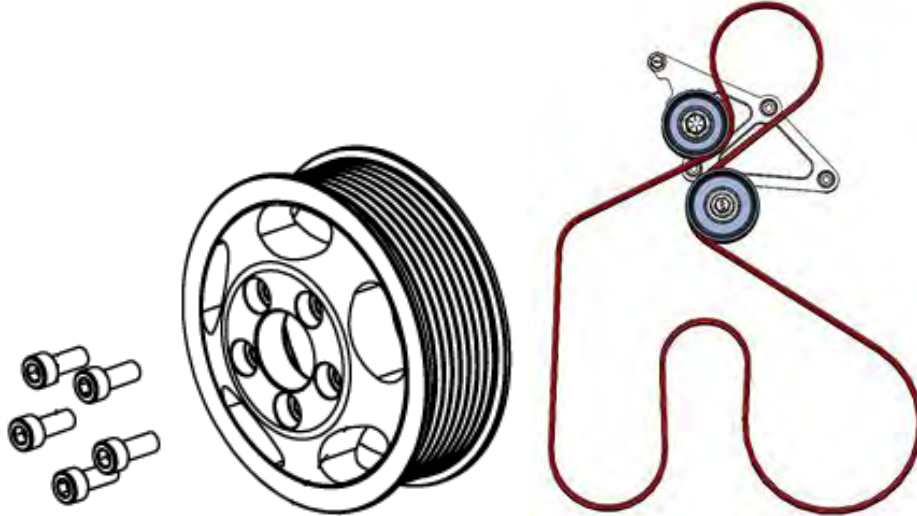

65. With the belt holding the SC pulley in position, torque the supercharger (5x) 6mm x 14mm SHCS bolts to 130 lbs-in using a 5mm allen socket. Do not use Loctite on threads, it is not required.

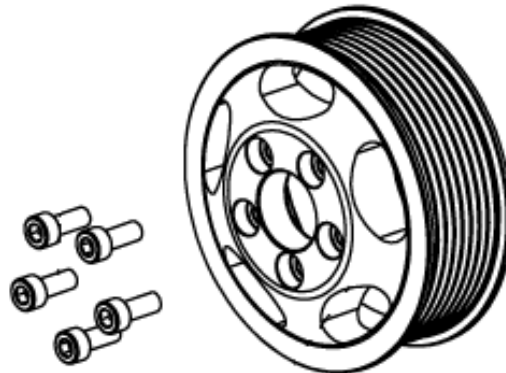

66. Using the supplied 5/16" OD silicone tube, install the (1x) 80 1/2" cord. Start as shown with green arrow, go in a clockwise motion, to the front, then around the perimeter. End at yellow arrow position. Bunch it up so it has no gap at the end as any gap will be an air leak of un-intercooled air. Install the (1x) 6.5" cord in the front section shown with the blue arrow.

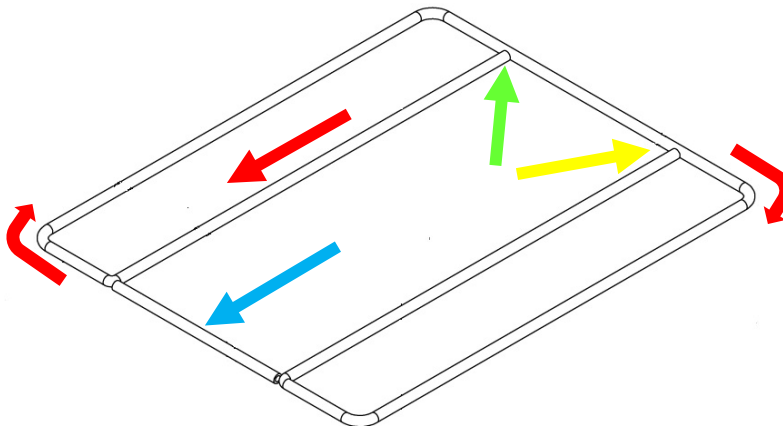

67. Install the supplied pre-formed 65.3" x .103" oring to the top sealing surface of the SC housing. Apply generous

amount of grease to help ease the oring into place. **TIP:** To install oring into dove-tail groove, press vertically, vs sliding finger along.

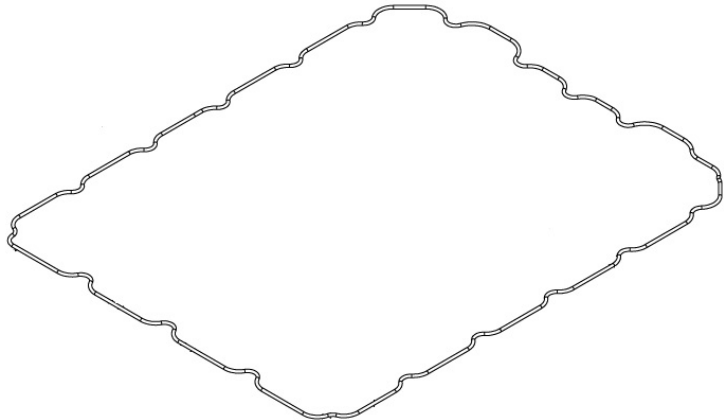

68. Install the (1x) #2-230 internal bypass oring to the lid bypass passage. Use generous amount of grease to secure oring in place and help with installation.

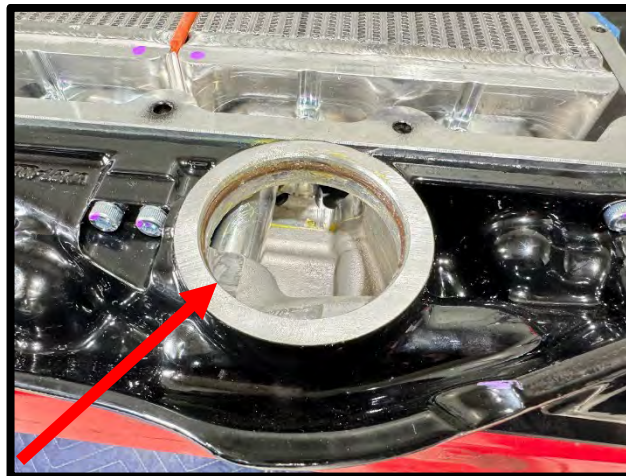

69. Apply generous amount of grease to the (1x) #2-230 Viton bypass oring. Install the supercharger lid to the supercharger housing by carefully placing the bypass down. Secure the SC lid using the (17x) 6mm x 30mm HHFCS and (3x) 6mm x 70mm HHFCS (*marked green*) using the following pattern (install EVAP bracket to 1 and 7). Torque to 90 lbs-in using an 10mm socket.

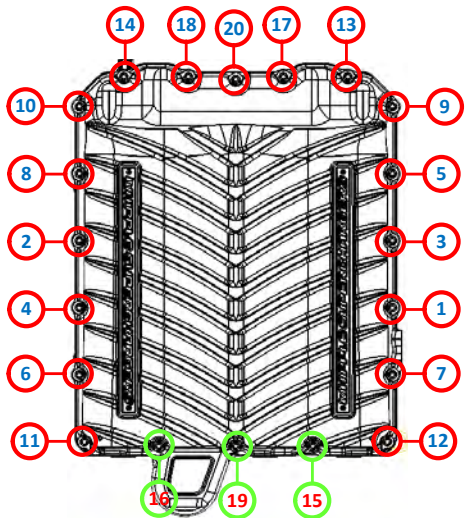

70. Install the (3x) supplied 6AN viton orings (#2-906) to the (1x) -6 ORB to 9.89mm, (1x) -6 ORB to 15.82mm and (1x) -6 ORB plug supplied. LH side, install the 9.89mm fitting in the top port using a 11/16" deep socket or wrench. LH side, install (1x) 6 ORB plug to the lower port using a 6mm allen socket. RH side, install (1x) 15.82mm fitting to port using a 7/8" deep socket.

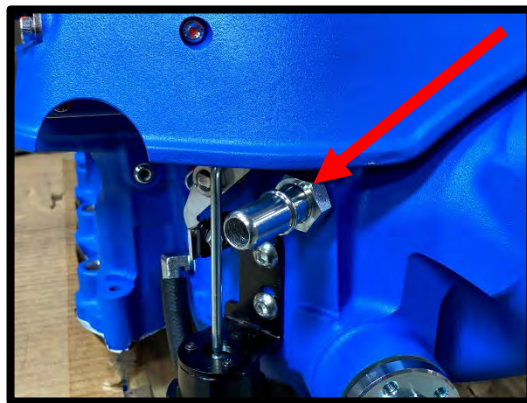
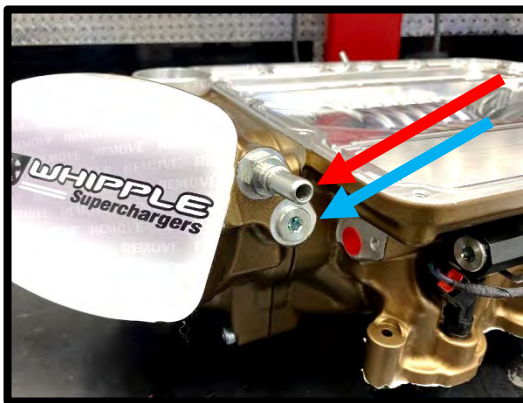

71. Connect the supplied PCV line from RH valve cover and SC.



72. Slide the EECPV to bracket by sliding onto bracket. Connect factory plastic quick connect fitting to EECPV until it clicks and locks into place. Connect 2-way electrical connector to EECPV, press locking tab back in place. Install the supplied 3/8" ID x 5 1/2" with 55deg quick connect fitting hose (#5000030) to the EECPV barb fitting and **upper** quick connect fitting on SC inlet. Push until it clicks and locks into place.

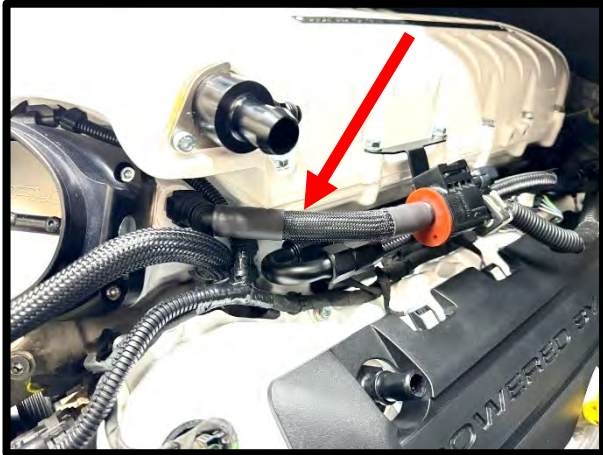

73. Apply light amount of pipe Teflon to supplied 1/8" NPT to 1/4" barb fitting. Install fitting to the open port on the SC inlet (vacuum source). Install the supplied 1/4" ID premade hose to the bypass actuator barb and 1/4" fitting on SC inlet (goes over PCV fitting). **CAUTION:** Verify hose can't kink or bend.



74. Install the (1x) 2-123 oring to each IC fitting. Apply light amount of grease to orings. Install fitting with 1/8" NPT port to LH fitting port. Install fitting with no port to RH side of lid. Secure fittings with forks and (1x) 6mm x 15mm SHCS per fitting. Torque to 89 lbs-in. Install the IC outlet fitting with 1/8" NPT port facing rearward on the LH side.

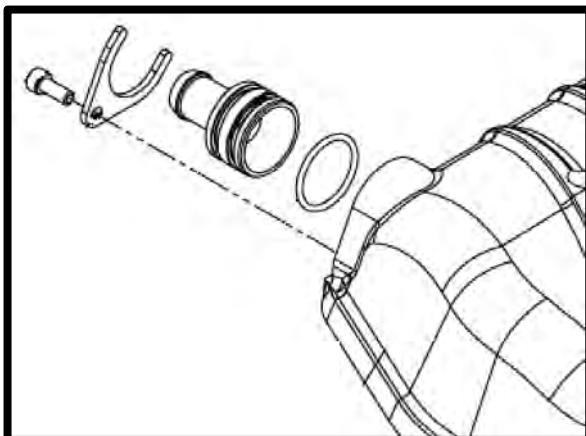

75. Install the 1/8" NPT to 6AN fitting to the IC outlet fitting. Apply light amount of pipe Teflon to pipe fitting.



76. Install the -6 150deg push lock fitting to -6 fitting on the LH IC outlet hose. Install the supplied 3/8" x 32" hose to fitting and route to degas bottle. Secure to degas bottle using factory clamp.

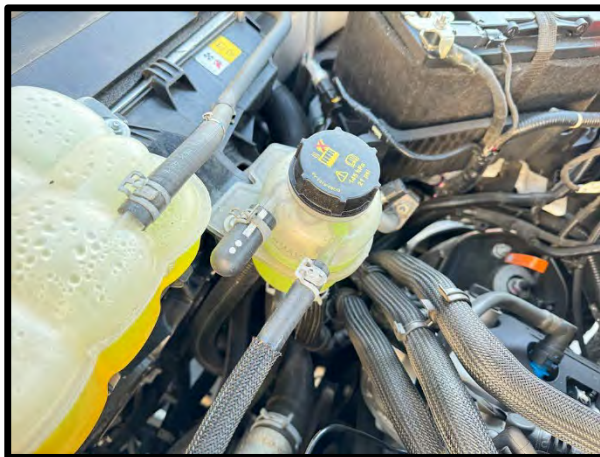

77. Using the 3/4" x 10" hose, cut the factory feed hose (after IC coolant temp sensor), install supplied 3/4" hose barb and (2x) shrink clamps. Apply heat to shrink clamps. Install supplied sleaving and heat shrink to cover hose. Connect hose to RH IC fitting, secure with supplied black #12 worm clamp.

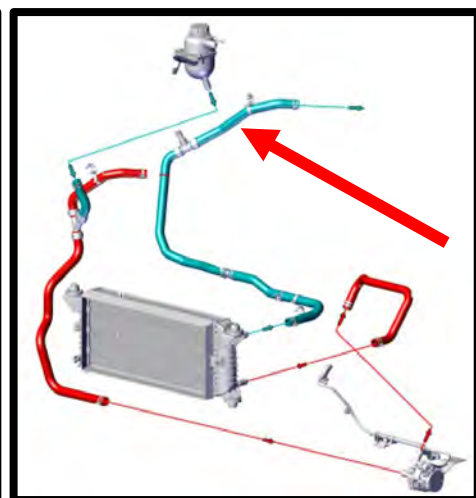

78. Using the 3/4" x 19" 90deg hose, cut the factory return hose, install supplied 3/4" hose barb and (2x) shrink clamps. Apply heat to shrink clamps. Install supplied sleaving and heat shrink to cover hose. Connect hose to LH IC fitting,

secure with supplied black #12 worm clamp.

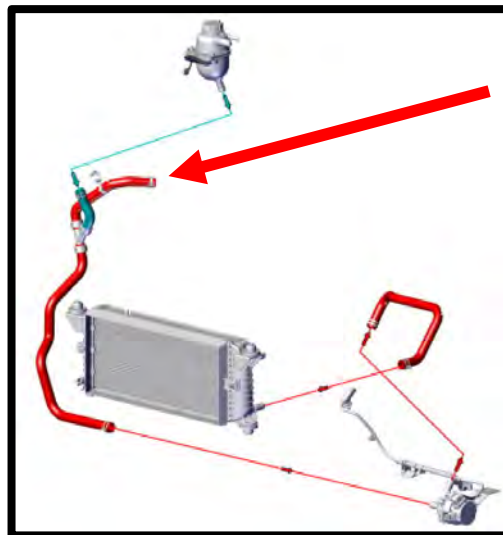

79. Reconnect factory vent line to degas bottle using stock clamp.

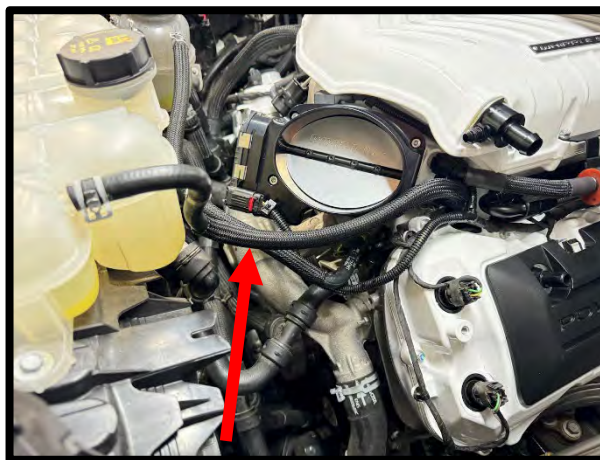

80. Using the previously removed stock TMAP sensor, install stock SIP sensor to Whipple inlet. Apply grease to oring to ease installation. Secure using supplied 5mm x 18mm HHFCS bolt. Torque to 72 in-lbs.

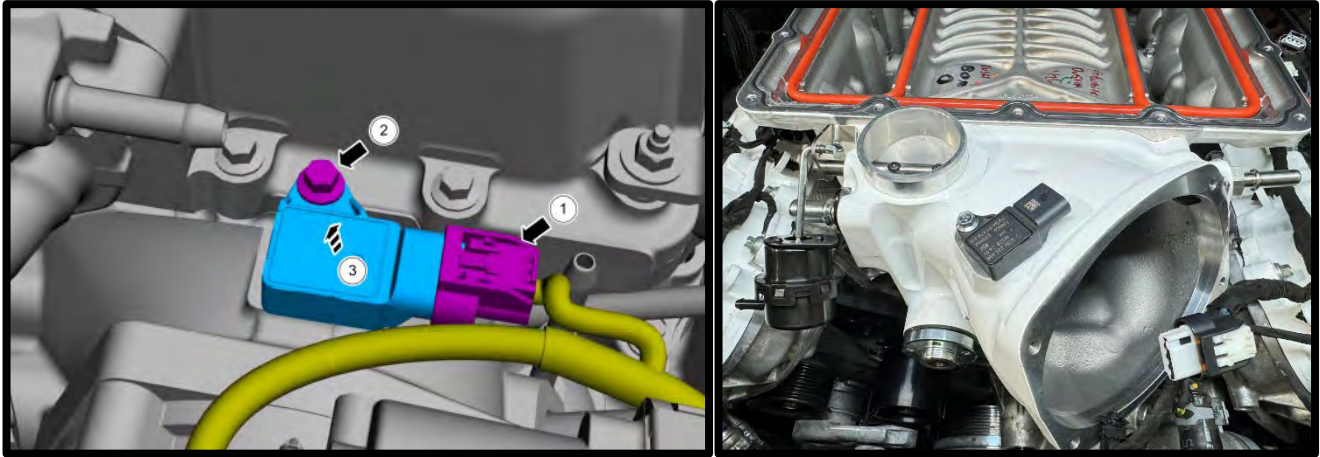

81. Install throttle body to supercharger inlet, use the supplied gasket between TB adapter and SC inlet. Secure with the supplied (3) 6mm x 25mm SHCS and (1) 6mm x 50mm SHCS using a 5mm allen socket. Torque to 106 lbs-in on first pass, 135 lbs-in in a cross-pattern. ***NOTE:** Failure to torque properly can cause throttle related issues.

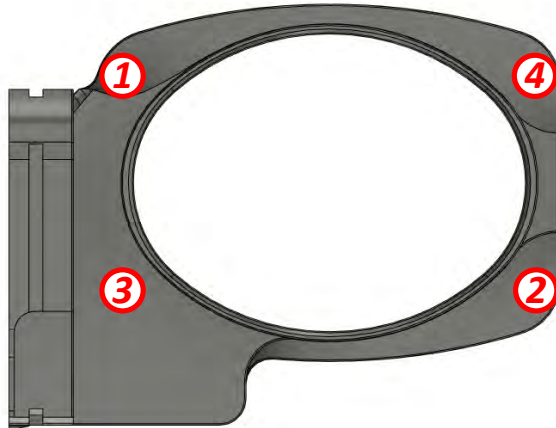

82. Separate the SIP sensor and electronic throttle harness by using razor blade to cut electric tape on stock harness, install supplied split loom, secure with automotive grade electric tape. Secure ETC and SIP sensor connectors.

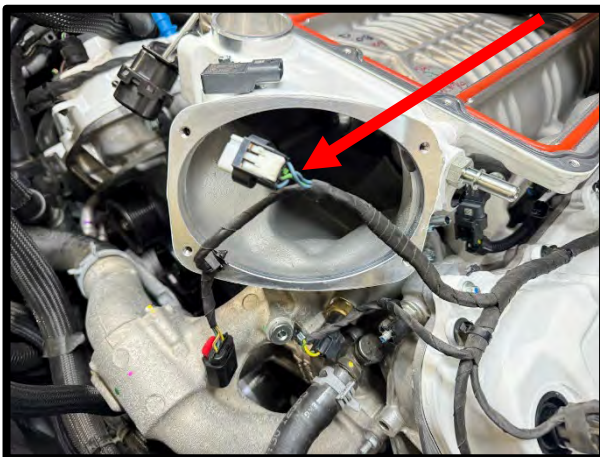

83. Modify the airbox for increased airflow (stock box is limited). Mark an area on the front corner, next to the snorkel. Using a saw, cut an open area to increase the airflow. Clean area before proceeding.



84. Reinstall stock airbox into stock location. Install new supplied air filter element. Reconnect the retainers from the air cleaner. Reconnect the IAT sensor electrical connector.

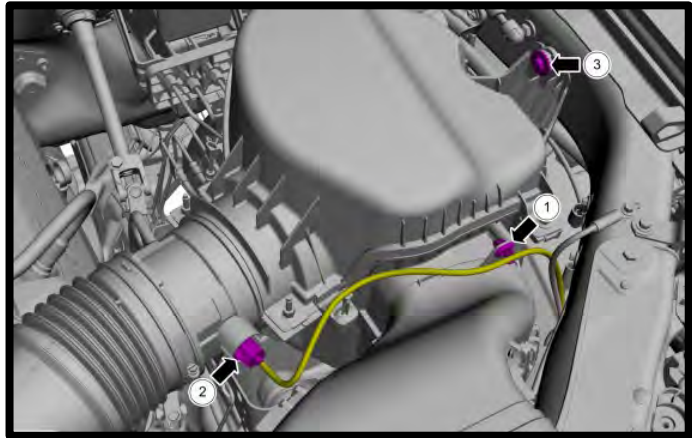

85. Connect the new inlet air tube between the airbox and throttle body. Secure using stock clamp on airbox side and supplied #80 hose clamp. Reconnect the crank case vent tube and bypass vacuum line from inlet tube.

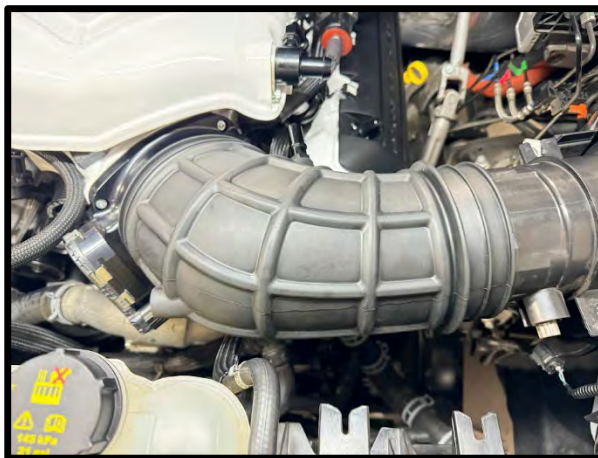

For the best result, it is highly recommended to use a Radiator Cooling System Vacuum Purge and Refill Kit to properly evacuate the air from the intercooler system before filling the 50/50 mixture of coolant and distilled water. If one is not available, the following procedure will be adequate.

86. Reattach the negative cable to the battery and tighten using an 8mm wrench.
87. Refill the Engine coolant. Verify that your coolant drain is closed, use a filter/strainer to pour the recycled coolant/water mixture that you drained from the radiator. If necessary, top off with a **Ford approved engine coolant**. Whipple also recommends running 2 bottles of Redline Water Wetter which can be found at most automotive parts stores. **⚠ WARNING!! NEVER USE TAP WATER OR ANY NON-FORD APPROVED COOLANT, THIS WILL CAUSE CORRISION IN THE SYSTEM.**
88. Remove the degas bottle cap. Inspect degas bottle cap and degas bottle for any issues that would cause improper sealing, such as cross-threading, burrs, damaged orings, etc. If any issues are found, or if coolant expelled through the cap potentially leaving contamination in the gasket, INSTALL a new cap and/or degas bottle.
89. Turn the ignition to the **ON** position, after a brief delay, the electric pump motor will cycle. Air bubbles will begin to rise to the degas bottle as the coolant level drops, continue to fill while pump is running. Once done filling, turn the ignition key **OFF**, the level will drop, top off with fluid. Reinstall cap and turn the ignition **ON** and let run for 15 seconds. Turn key **OFF**, remove cap to release air. Repeat until the degas bottle holds at OEM level with key **OFF**. To build more pressure in the intercooler system, try squeezing the intercooler inlet and outlet hoses simultaneously while the pump is on. Building pressure in the system will help push trapped air from intercooler system to the degas bottle. Repeat until the sound of the electric pump is continuous without pulsation and fluid level is met at the degas bottle. **NOTE: During water pump start-up, its normal for slight pulsation to occur. Once the pump has reached its maximum cycle speed, no pulsations should be present. If any pulsations occur, there is air in the system. NEVER GO WOT UNTIL AIR IS BLED OUT!**
90. Attach the pressure tester and adapter (Snap-On TA53 or equivalent), to the degas bottle cap. The cap must hold pressure of 145 KPA +/- 21 KPA (21psi +/- 3psi). If any issues are found, INSTALL a new cap.
91. Attach the Pressure Tester and adaptor (Snap-On TA52, AST ASSFZ-47, Redline RDL95-0750 or equivalent) to the degas bottle. **NOTE: Do not pressurize the cooling system beyond the maximum pressure listed in the Specifications table in this section or cooling system components may be damaged. NOTE: If the plunger of the pressure tester is pressed too fast, an erroneous pressure reading results.**

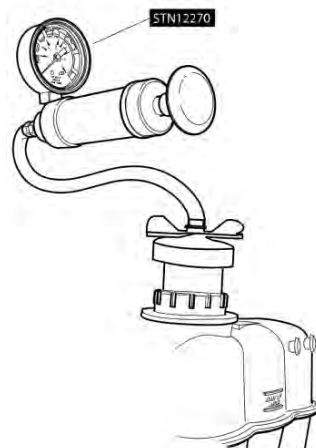

92. To pressurize the cooling system, slowly press the plunger of the pressure test pump and increase the pressure to between 124 - 138 kPa (18 - 20 PSI). Observe the gauge reading for approximately 2 minutes. Pressure should not drop during this time. If the pressure drops within this time, inspect for leaks and repair as necessary. **NOTE:** If no leaks are found and the pressure drops, the leak may be internal to the intake manifold.

WARNING: Always avoid removing the filler neck cap when the system is hot. The hot coolant is under pressure and may spray out causing burns.

WARNING: Triple check that the intercooler system is properly bled. Failure to do so can result in engine damage. Start the engine, let the pump run for 60 seconds, there should be zero cavitation during this test.

93. Before driving, make sure that you have 91 or higher-octane fuel in the system (RON+MON)/2. Not ½ tank of 87 and ½ tank of 91, all 91 or better fuel in the system. Never, ever mix questionable or low octane fuel with new fuel. The Mustang fuel system is return less, this means the fuel does not return to the tank, even if you put new fuel in tank, the fuel in lines, filter and pump are going to be the other fuel. This can be up to 3 gallons worth of fuel. Running this fuel, even with low load can damage the engine.
94. Test drive vehicle for the first few miles under normal driving conditions. Listen for any noises, vibrations, engine misfire or anything that does not seem normal. The supercharger does have a slight whining noise under boost conditions, which is normal. Using the flash tool provided, monitor the MCT (manifold charge temp), this should stay between 0-40deg above ambient, if it exceeds this, you will need to continue to bleed the air out of the intercooler water system. Monitor the knock sensor activity, + is adding timing, - is removing timing. Its standard for it to bounce back and forth.
95. Re-check the radiator and intercooler degas bottle level regularly over the first 1,000 miles, top off level as needed.
96. Re-check SC oil level regularly over the first 1,000 miles, level may drop very slightly as it fills the bearings and cavities.
97. Inspect belt system and readjust. It's common for the belt to stretch after first heat cycle.
98. If adding a boost gauge, Whipple has provided an extra 1/8" NPT port at the back of the SC for easy installation. Remove pipe plug using ¼" allen socket, install boost gauge adapter (Whipple not supplied).

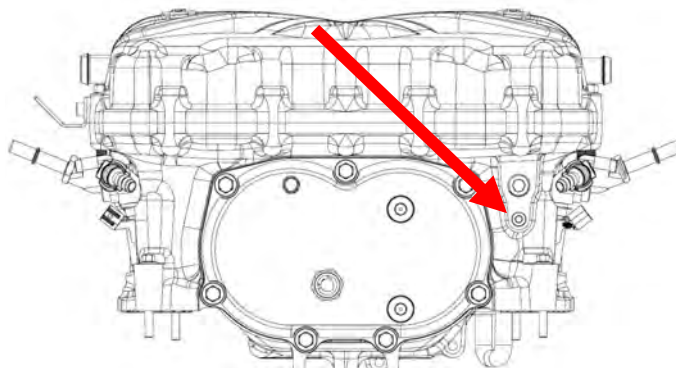

99. After the initial test drive, go through the belt tensioner process again. On the next test drive, gradually work the vehicle to wide open throttle runs. Listen for any engine detonation (pinging). If engine detonation is present, let up on the throttle immediately. Most detonation causes are low octane gasoline still in the tank.
100. If you have questions about your vehicle's performance, please check with your installation facility or call Whipple Superchargers at 559.442.1261, Monday through Friday from 8am to 5:00pm, pacific time or email questions to tech@whipplesuperchargers.com.

⚠ WARNING!! Verify the bypass actuator is working properly. To monitor, look at the bypass arm when the motor is not running. Start engine and verify that the actuator arm has opened. This arm will be extended when the engine is above 2" of vacuum (boost) and will be open when there is more than 3" of engine vacuum. **DO NOTE MANUALLY MOVE ACTUATOR, DAMAGE MAY OCCUR!**

There is a great deal of misinformation about the function of supercharger bypass systems. The supercharger is a positive-displacement pump; that is, so long as it is rotating, it is always pumping air. During low demand or high vacuum operation (i.e. idle, deceleration, and light throttle cruise), the pumping action is undesirable as it creates unwanted heat and noise. The bypass circuit, when open, prevents any pressure buildup across the supercharger and allows air to circulate through the rotors, allowing the supercharger to "idle" freely during these conditions. This results in reduced noise, and by reducing heat buildup in the intake, significantly improves street and strip performance. As throttle demand increases, the bypass circuit is closed, resulting in full performance and strip performance. As throttle demand increases, the bypass circuit is closed, resulting in full performance from the supercharger. The bypass circuit is never used to limit or control boost during full-throttle operation and defeating or altering the bypass function will not result in improved performance in any condition and will result in poor drivability and possible supercharger damage.

MAINTENANCE AND SERVICE

Be sure to follow the maintenance and service recommendations below to optimize the life and performance of your Whipple-supercharged vehicle.

For best performance and continued reliability, it is essential to adhere to the following guidelines:

1. Use only premium grade fuel (91-octane or higher). RON+MON/2. The PCM calibration will automatically detect higher octane levels and will increase power accordingly.
2. Always listen for any sign of spark knock or pinging. If present, discontinue use immediately and consult your vehicle owner's manual.
3. Do not operate the vehicle at large throttle opening if the MIL lamp is on steadily. This indicates an electronic engine control malfunction: reduce throttle opening and consult your vehicle dealer.
4. Check the supercharger oil level at every engine oil change. Add Whipple SC oil to the supercharger if required. Do not overfill the supercharger rear gear case.
5. Change the oil in the supercharger every 50,000 miles. Use Whipple SC oil or Ford #XL-4 only. **NOTE: If spinning the SC faster than standard operation, oil should be changed earlier. Severe damage will occur if oil level is over filled.**
6. Check intercooler level at the IC degas bottle every 7500 miles. Level should be the same as stock.
7. Inspect and clean your high-flow air filter element every 7,500 miles.
8. Inspect and replace spark plugs every 20,000 miles.
9. Follow your factory service intervals for oil changes and other typical maintenance items.
10. Check the supercharger/accessory drive belt. Adjust or replace as required

CAUTION: Any modification to your vehicle's new computer program may cause serious damage to the engine and/or drive train. The PCM is locked to the VIN, never let anyone, including dealerships install updates to the PCM. Modifications to the PCM will lock power to stock power levels and are not emissions legal.

CONGRATULATIONS

Your new Whipple Supercharger is engineered to significantly increase your engines power across a broad range of RPM's. It is Whipple's goal to improve your driving experience for many miles and years to come.

Whipple Superchargers operate as an air pump and contain internal rotors that are driven by the engine's crankshaft and serpentine belts. The supercharger compresses outside air and channels it into the engine's intake ports. Because of their design, superchargers may generate some additional noise over the standard, normally aspirated induction system.

At idle, you may hear a medium-pitch rattle from the supercharger main housing. This will diminish at about 400-500 rpm above idle.

You may also experience a muffled high-pitched whine during acceleration. This is caused by the pumping action of the supercharger compressing air and only occurs during boost conditions. It is inaudible during part-throttle acceleration.

These are normal noises associated with any supercharger and have no effect on supercharger performance or engine durability.

Your supercharger is warranted by Whipple Superchargers, please see your terms and conditions on the back of your invoice for more information in regards to the limited warranty. NOTE: Whipple Superchargers will not authorize any warranty repair work or supercharger replacement for normal noise.

IMPORTANT INFORMATION

DYNO INSTRUCTIONS

7th gear is closest to 1:1 which will show the highest power value on inertia-based dynos on the automatic. 5th gear is recommended for the 10 speed to limit tire and output shaft speed and stay safe with temperatures. Always have adequate airflow to the vehicle to avoid overheating. Always cool down for a minimum of 5 minutes between runs to allow the engine to cool off. Always listen for pinging/detonation, if you hear more than one ping, lift immediately.

BOOST LEVELS

All Whipple kits are shipped with boost levels that Whipple feels achieves maximum power while maintaining reliability with stock engines (@ sea level). Higher boost levels must run higher octane levels. Increasing boost levels increases risk of engine failure, void warranty and are no longer emissions legal.

EXHAUST

Cat-back exhaust systems help reduce heat and minimize exhaust back pressure. They do not affect the calibration and are always a good idea for added safety and performance. Long tube headers and/or high flow cats greatly affect emissions and O2 sensor readings, these are not emissions legal and are not supported in anyway.

FUEL OCTANE

There is a large variance in quality of fuels. Top Tier fuel is from large name brands such as Shell, Chevron, Unocal, Sunoco, Texaco, Phillips and others. Secondary fuel is common from grocery chains, liquor stores and small convenient shops. Never run fuels from secondary suppliers. Never run a fuel octane that is below 91octane, $(RON+MON)/2$ and never run fuel with more volume than 10% Ethanol (E10). It is recommended, when available, to run 92-94 octane. Never mix mid-level (below 91) with 91+, this is very dangerous and can cause severe engine damage. Do not attempt to increase octane ratings with generic octane boosters, these are very hard on spark plugs and many brands do very little to the actual octane rating (1 point is .1 octane). The PCM constantly adapts, if it senses better fuel, it will optimize power.

FUEL LEVEL

Never operate at WOT when the vehicle fuel levels are below a 1/8 tank. Low fuel levels could cause the fuel pump to cavitate and you'll have fuel flow spikes resulting in lean conditions and consequently detonation.