

WHIPPLE

2019-2021 2.3L ECOBOOST FORD RANGER STAGE 1 INSTALLATION MANUAL

WHIPPLE PN: EB-8162

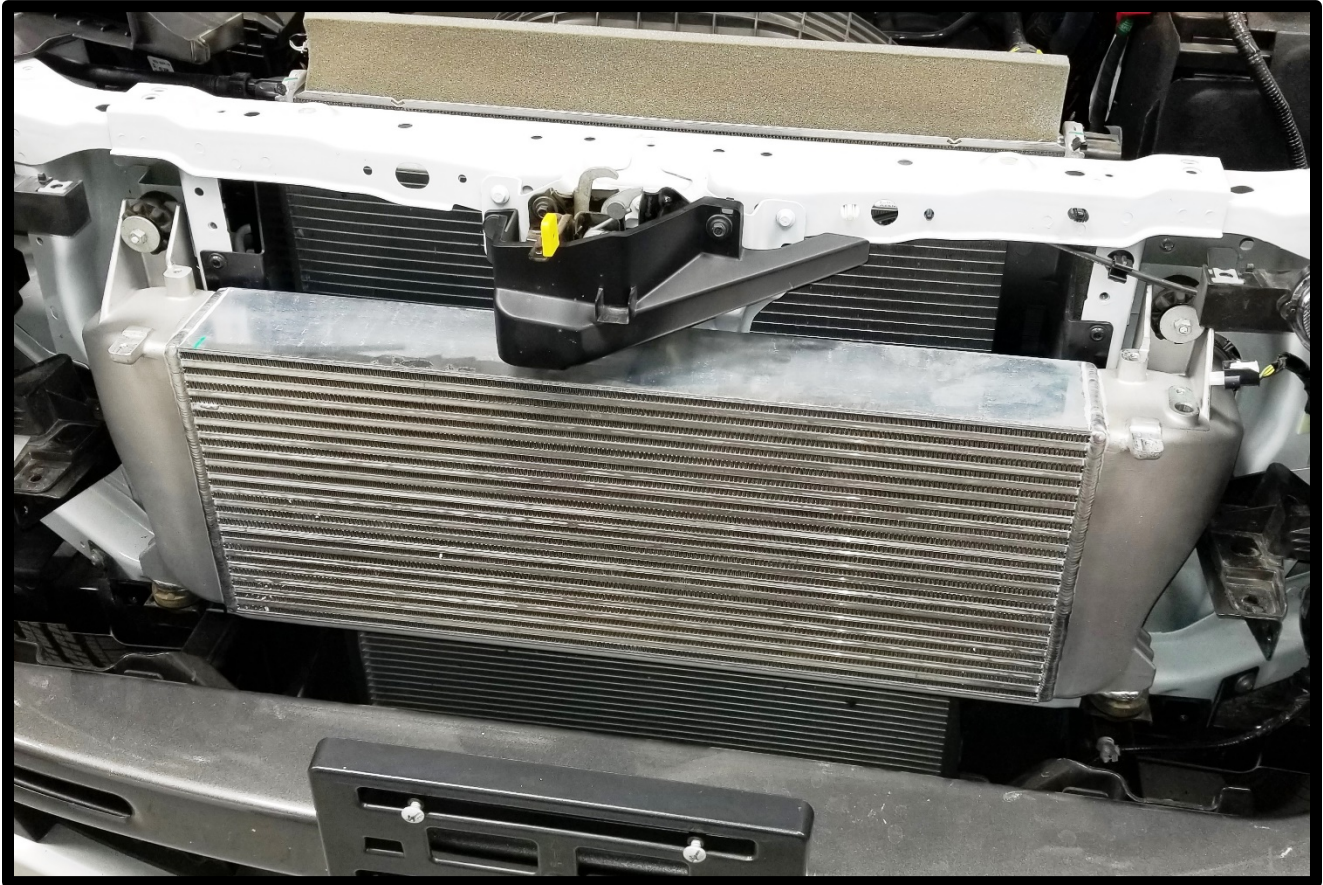

WHIPPLE SUPERCHARGERS
3292 NORTH WEBER AVE
FRESNO, CA 93722
TEL 559.442.1261
FAX 559.442.4153

www.whipplesuperchargers.com

PREMIUM FUEL ONLY (91 OCTANE OR BETTER ALWAYS) RON+MON/2

50 STATE LEGAL CARB EO #PENDING

COMPETITION BASED PRODUCT MAY BE USED SOLELY ON VEHICLES USED IN SANCTIONED COMPETITION
WHICH MAY NEVER BE USED UPON A PUBLIC ROAD OR HIGHWAY

INTRODUCTION

- Please read the installation manual and verify that all items are present. If you are missing hardware or have any questions, please contact your dealer or Whipple.
- **The turbocharger compressor vanes can be damaged by even the smallest particles. When removing any turbocharger or engine air intake system component, ensure that no debris enters the system. Failure to do so may result in damage to the turbocharger.**

COMPETITION BASED PRODUCT MAY BE USED SOLELY ON VEHICLES USED IN SANCTIONED COMPETITION WHICH MAY NEVER BE USED UPON A PUBLIC ROAD OR HIGHWAY, UNLESS PERMITTED BY SPECIFIC REGULATORY EXEMPTION (VISIT THE "EMISSIONS" PAGE AT [HTTP://WWW.SEMASAN.COM/EMISSIONS](http://www.semasan.com/emissions) FOR STATE BY STATE DETAILS.

COMPETITION BASED PRODUCT IS LEGAL IN CALIFORNIA ONLY FOR RACING VEHICLES WHICH MAY NEVER BE USED, OR REGISTERED OR LICENSED FOR USE, UPON A HIGHWAY.

IT IS THE RESPONSIBILITY OF THE INSTALLER AND/OR USER OF THIS PRODUCT TO ENSURE THAT IT IS USED IN COMPLIANCE WITH ALL APPLICABLE LAWS AND REGULATIONS.

SAFETY PRECAUTIONS



CAREFULLY READ THE IMPORTANT SAFETY PRECAUTIONS AND WARNINGS BEFORE PROCEEDING WITH THE INSTALLATION!

Appropriate disassembly, assembly methods and procedures are essential to ensure the personal safety of the individual performing the kit installation. Improper installation due to the failure to correctly follow these instructions could cause personally injury or death. Read each step of the installation manual carefully before starting the installation.

- Always wear safety glasses for eye protection.
- Place the ignition switch in the off position.
- Always apply the parking brake when working on vehicle.
- Block the front and rear tire surfaces to prevent unexpected vehicle movement.
- Operate the engine only in well-ventilated areas to avoid exposure to carbon monoxide.
- Do not smoke or use flammable items near or around fuel system.
- Use chemicals and cleaners only in well-ventilated areas.
- Batteries can produce explosive hydrogen gas which can cause personal injury. Do not allow flames, sparks or flammable sources to come near the battery.
- Keep hands and any other objects away from the radiator fan blades.
- Keep yourself and your clothing away from moving parts when the engine is running.
- Do not wear loose clothing or jewelry that can be caught in rotating or moving parts.

 **WARNING** 

****NOTICE:** Installation of Whipple products signifies that you have read this document and have agreed to the terms stated within.

It's the purchaser's responsibility to follow all installation instruction guidelines and safety procedures supplied with the product as it's received by the purchaser to determine the compatibility of the product with the vehicle or the device the purchaser intends to install the product on.

Whipple assumes no responsibility for damages occurring from accident, misuse, abuse, improper installation, improper operation, lack of reasonable care or all previously stated reasons resulting from incompatibility with other manufacturer's products.

There are no warranties expressed or implied for engine failure or damage to the vehicle in any way, loss of use or inconvenience or labor reimbursement. This includes merchantability and fitness.

The information contained in this publication was accurate and in effect at the time the publication was approved for printing and is subject to change without notice or liability. Whipple reserves the right to revise the information presented herein or to discontinue the production of parts described at any time.

INSTALLATION INSTRUCTIONS

It is strongly recommended that you read through this guide **before** you begin modifying your vehicle.

1. Disconnect the (-) negative cable from the battery, secure ground wire so it cannot arc.
2. Remove the (5) retainers from radiator shield and the (2) fasteners from the air intake duct. Release the tabs and remove the radiator sight shield.

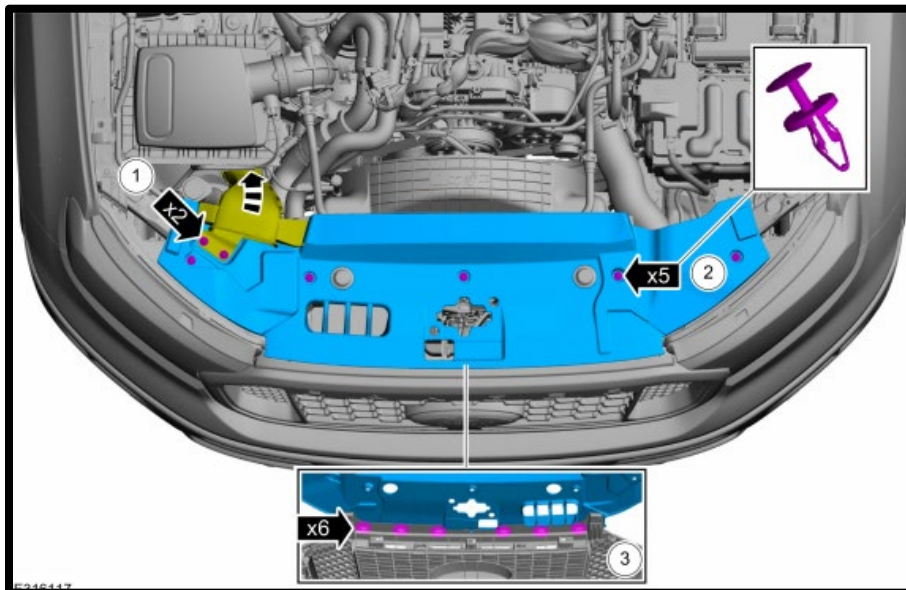

3. Remove the (2) bolts from grill.

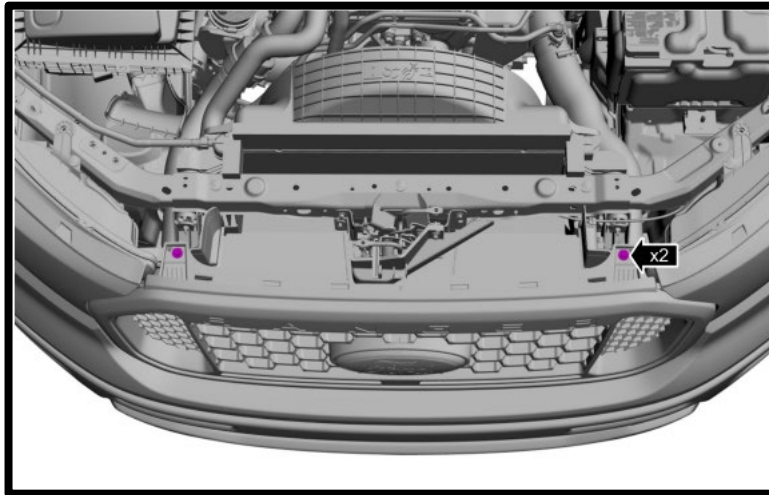

4. Remove the (4) screws and the radiator upper shield.

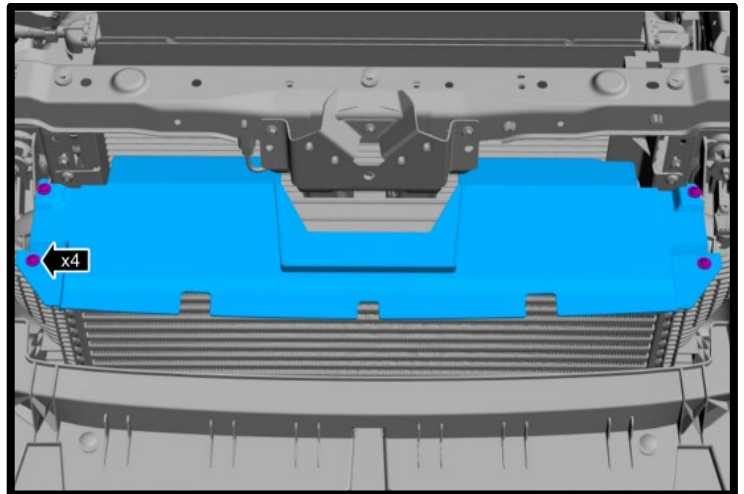
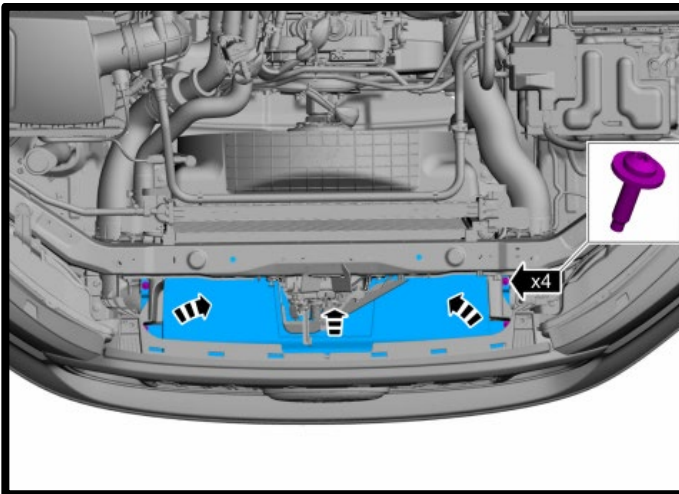

5. Using a flat blade screwdriver, release the locking tabs from front bumper. Remove the grille from vehicle.

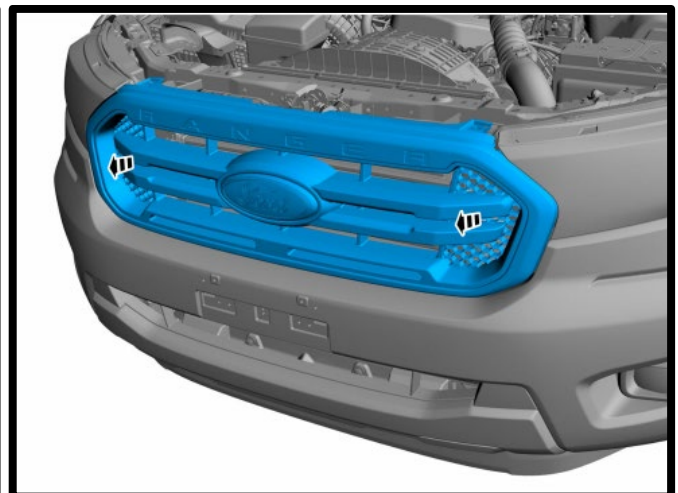
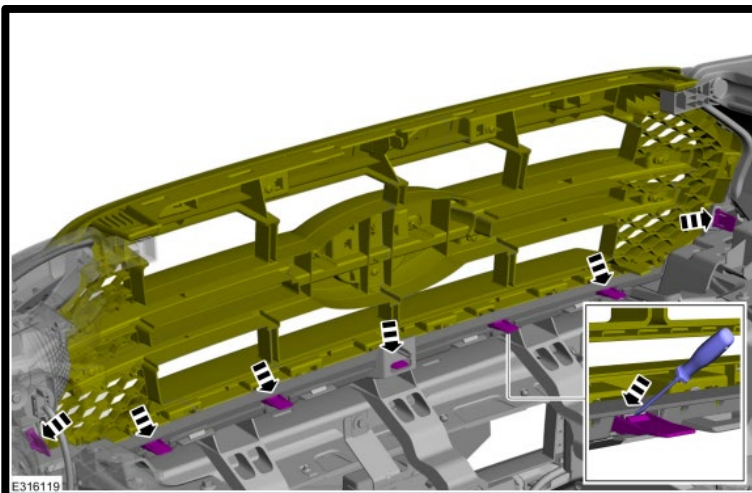

6. Remove the (2) fasteners from air deflectors.

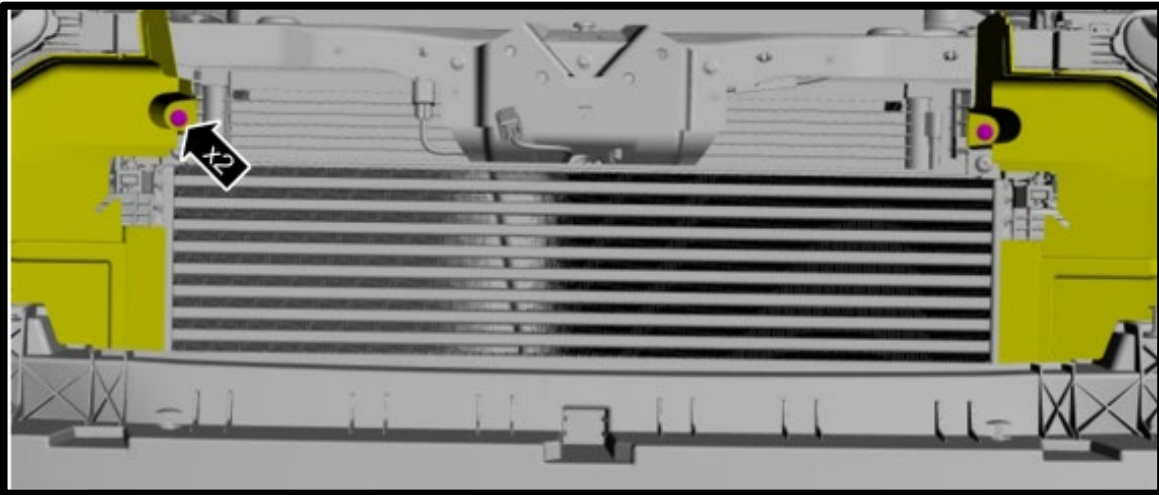

7. Disconnect the turbocharger boost pressure sensor electrical connector.

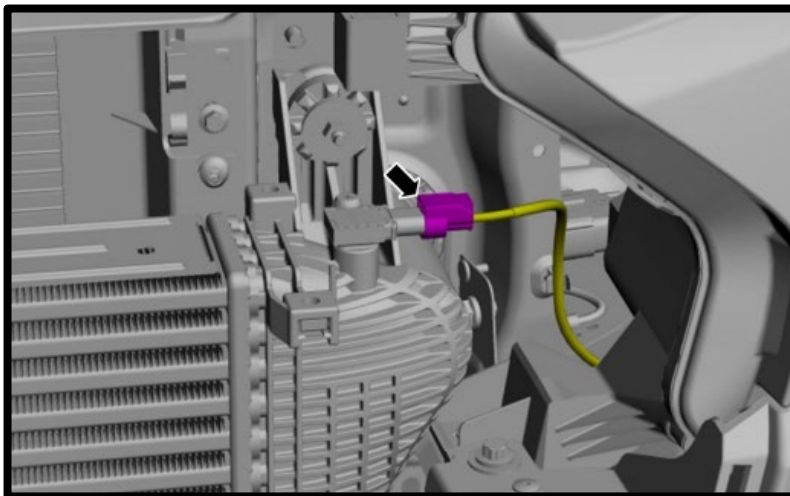

8. Remove the (2) fasteners securing intercooler to vehicle.

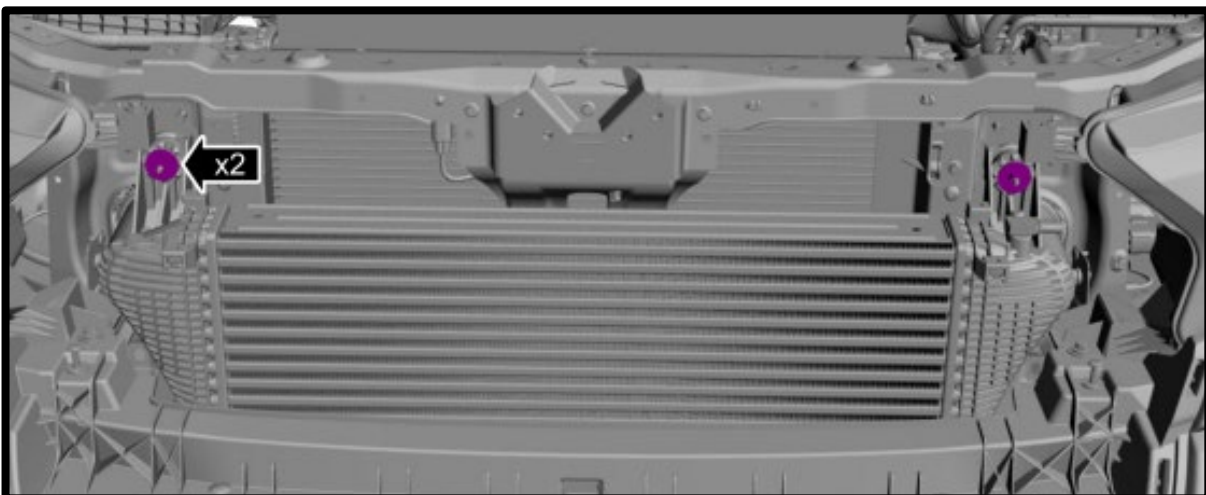

9. Release the CAC inlet pipe by spreading the retainer ends outward.

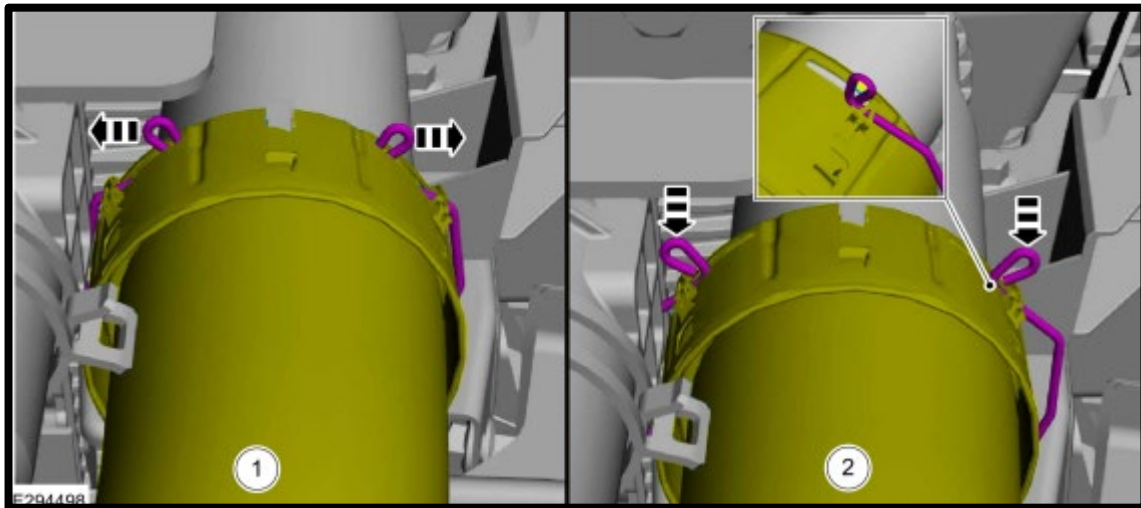

10. Position the retainer ends in the notches locking the retainer in the open position and position aside the CAC outlet pipe.

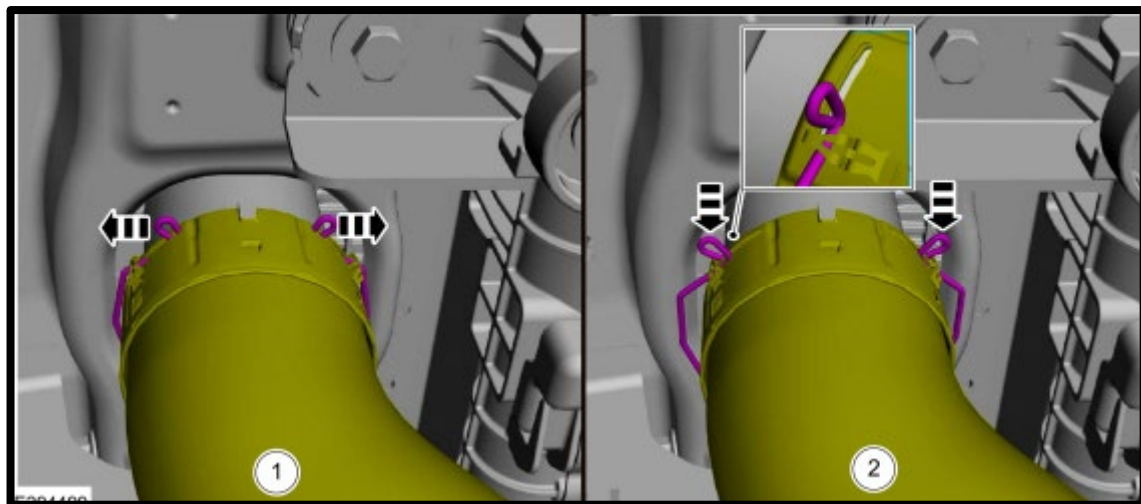

11. Remove the (4) fasteners and front skid plate. If proper access to skid plate is not available, jack the vehicle up, install jack stands using the factory lifting points.

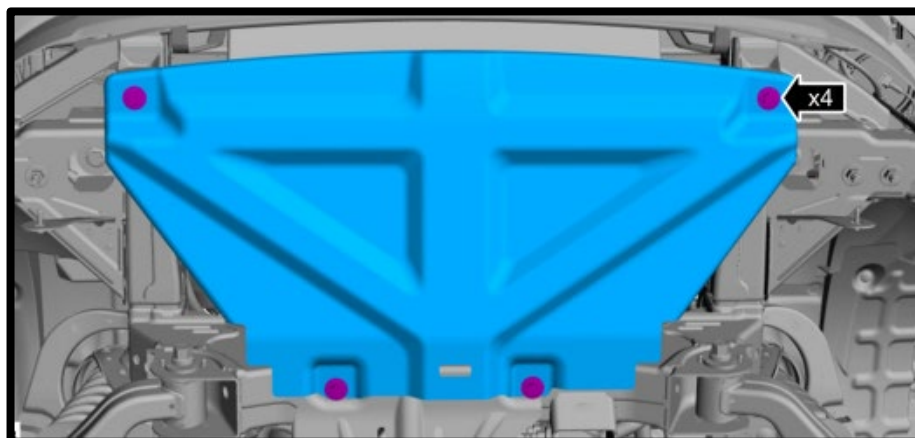

12. RH and LH are similar, remove the fasteners from bottom of intercooler mounts.

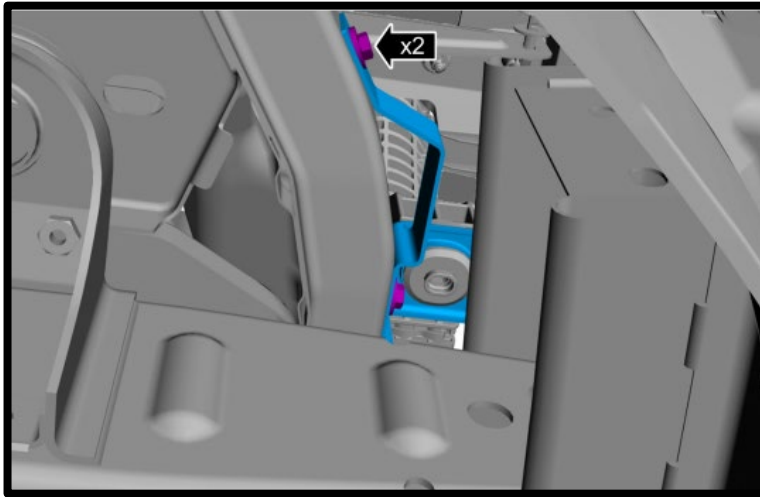

13. Remove the (1) fastener and (1) push pin to remove the hood latch cover.

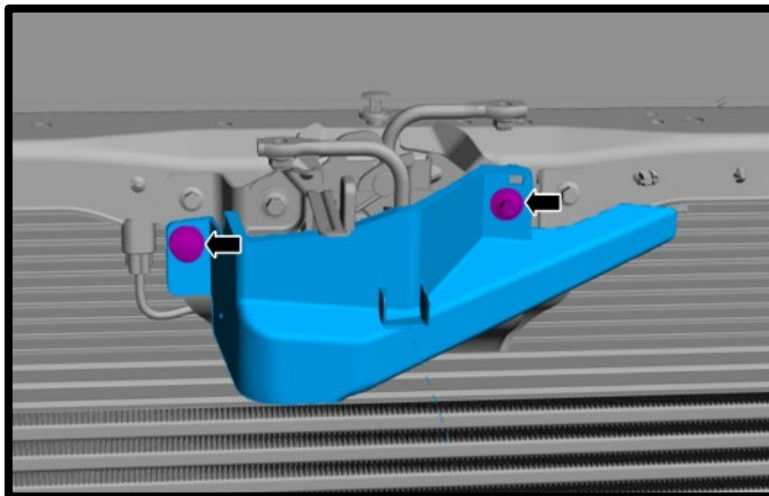

14. **Mark the position of the hood latch bracket, this will aide in reinstallation.** Disconnect the electrical conner. Remove the (2) fasteners from hood latch.

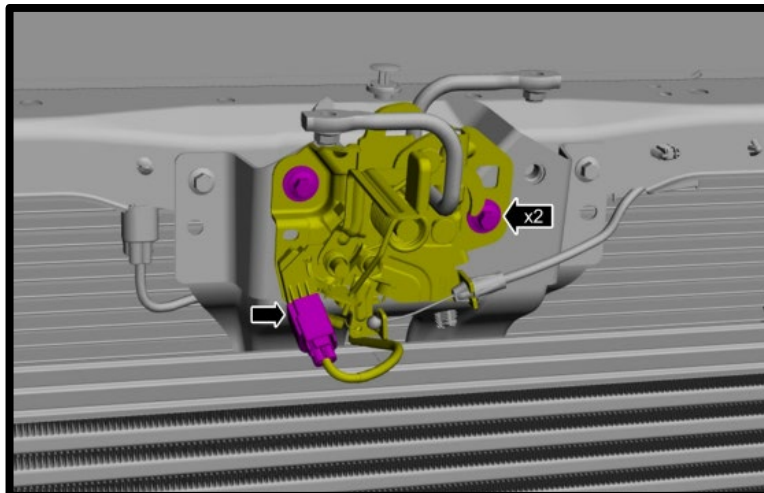

15. Remove the isolators and intercooler from the vehicle.

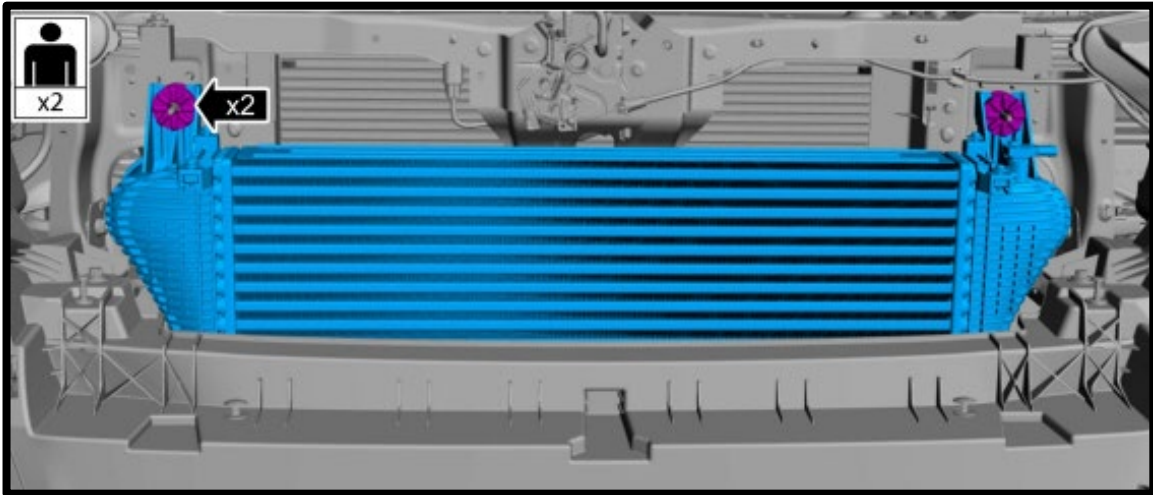

16. Remove isolators from stock intercooler. Transfer to new intercooler core. Install core into factory location.



17. Secure new intercooler using the (4) factory fasteners previously removed. Torque to 97 in-lbs.

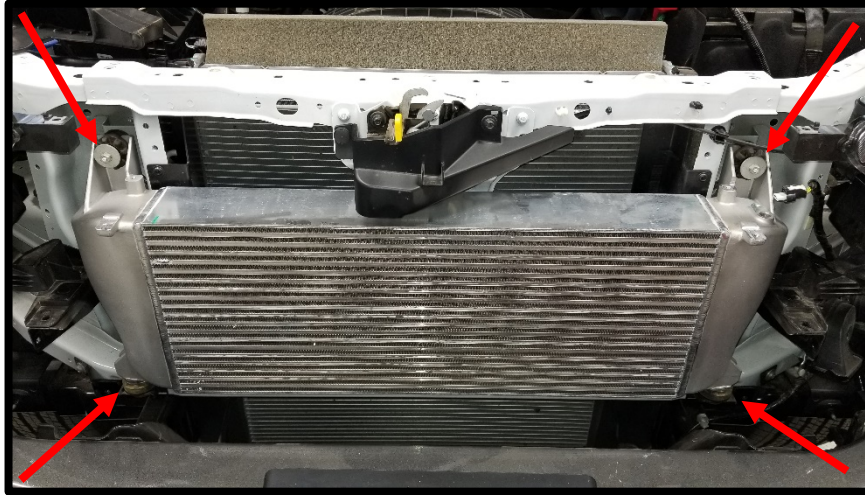

18. Reconnect inlet and outlet pipes using factory connections.

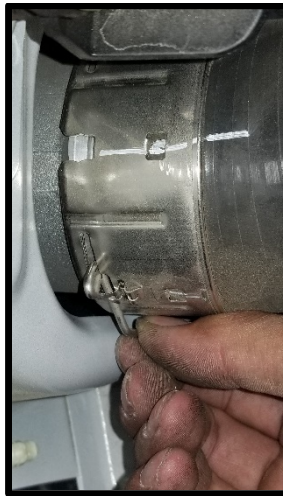

19. Remove the MAP sensor from stock intercooler by removing the (1) fastener. Apply light amount of grease to oring, install to new intercooler using supplied (1) 6mm x 16mm bolt. Reconnect factory electrical connector.

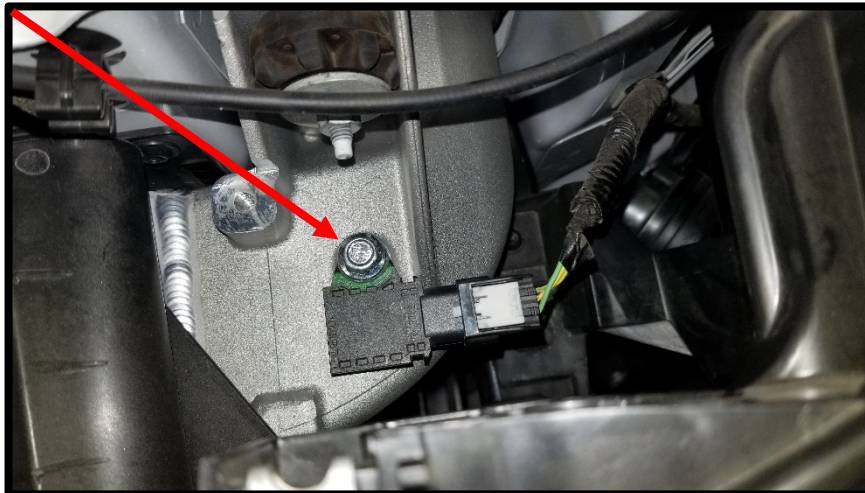

20. Reinstall the (2) fasteners to hood latch. Reconnect electrical connector. Torque to 97 in-lbs.

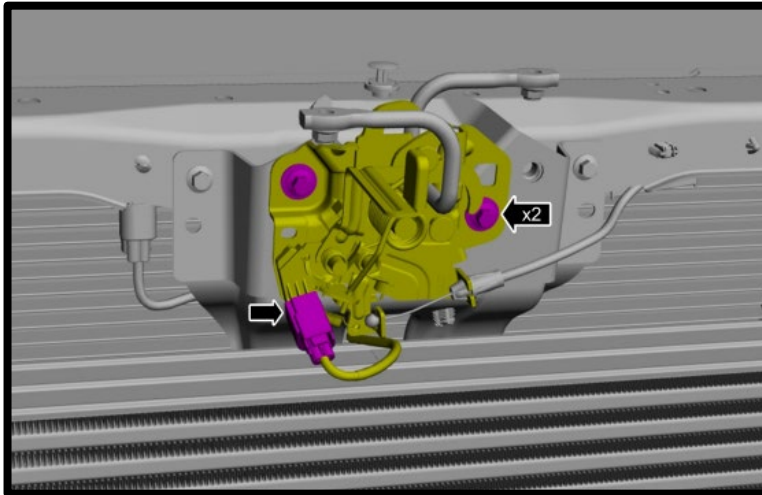

21. Reinstall the (1) fastener and (1) push pin to secure hood latch cover. Torque to 97 in-lbs.

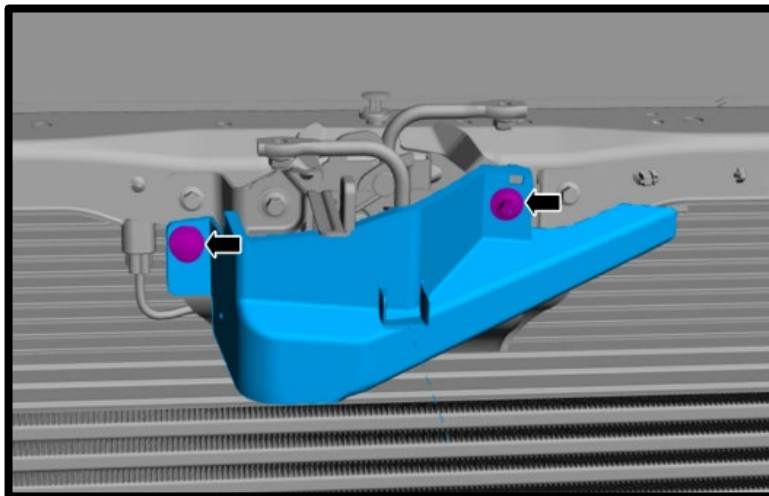

22. Reinstall the (4) fasteners and front skid plate. Torque to 22 ft-lbs.

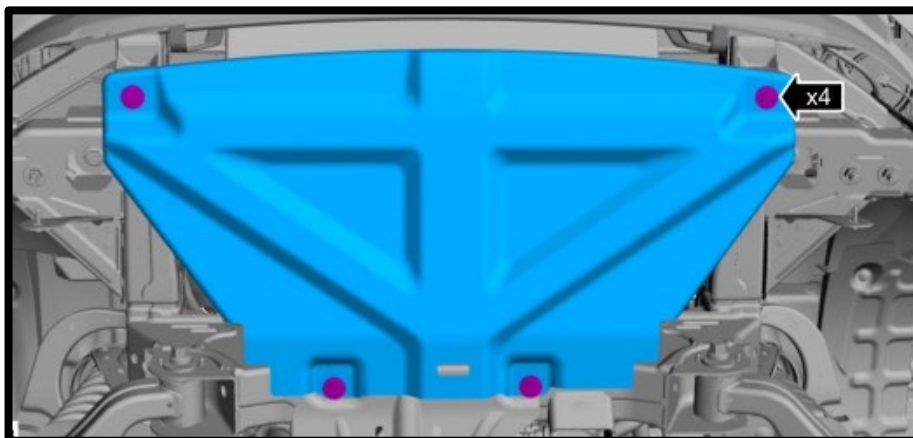

23. Reinstall the (4) screws and the radiator upper shield. Torque to 42 in-lbs.

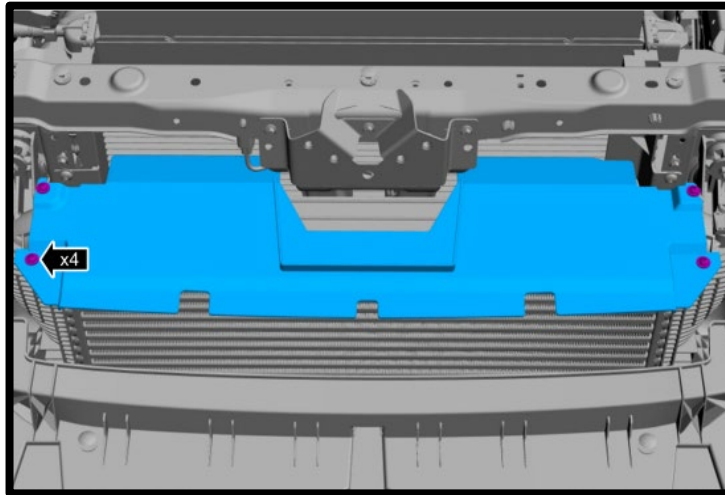

24. Reinstall the (2) fasteners that secure air deflectors. Torque to 42 in-lbs.

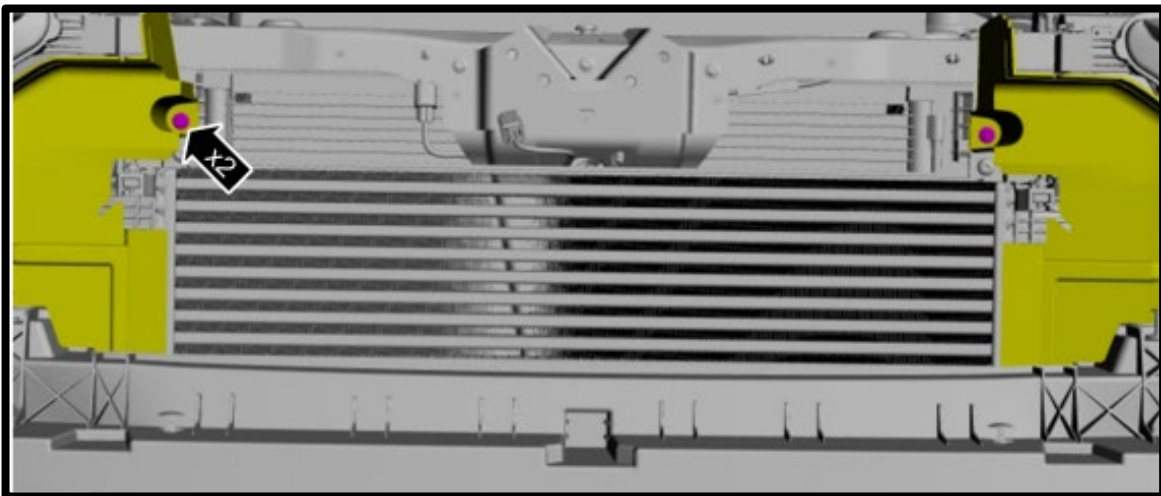

25. Reinstall grill. Secure grill using the (2) bolts previously removed. Torque to 44 in-lbs.

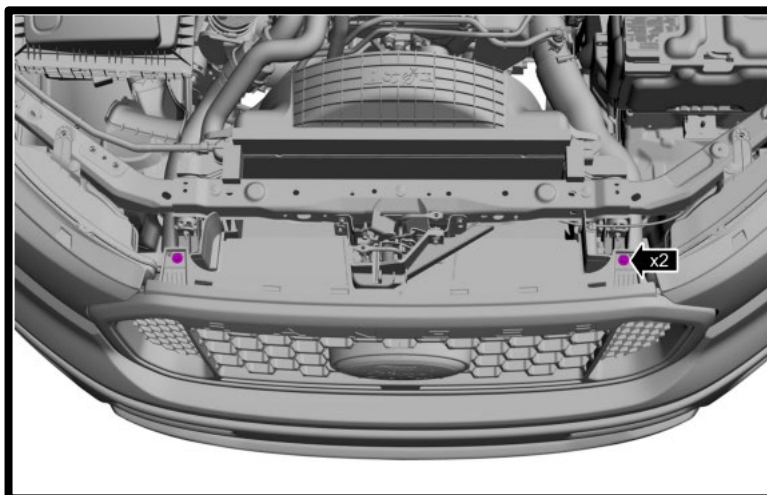

26. Reinstall the (5) retainers to secure radiator shield. Reinstall the (2) fasteners to secure air intake duct.

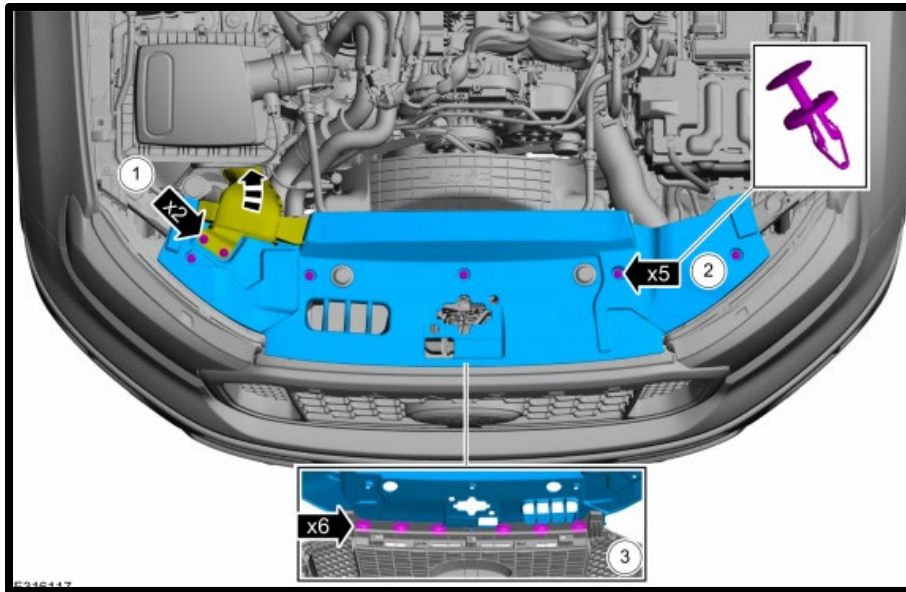

27. Remove the stock air filter, replace with high flow filter element.
28. Install the supplied 50-state legal sticker decal to the underside of the hood, next to the factory emissions sticker. Decal needs to be in visible area. Use light amount of acetone to clean surface before installing.
29. Start the vehicle, check for any leaks or check engine lights.