



2021 AND UP FORD BRONCO

STAGE 1 PERFORMANCE KIT
2.3L/2.7L ECOBOOST

WHIPPLE PART NUMBER #EB-8180, EB-8180-NFT



WHIPPLE SUPERCHARGERS

3292 NORTH WEBER AVE

FRESNO, CA 93722

TEL 559.442.1261

FAX 559.442.4153

WWW.WHIPPLESUPERCHARGERS.COM

PREMIUM FUEL ONLY (91 OCTANE OR BETTER ALWAYS) RON+MON/2

CALIFORNIA AIR RESOURCE BOARD EXECUTIVE ORDER #D231-73

**COMPETITION BASED PRODUCT MAY BE USED SOLELY ON VEHICLES USED IN SANCTIONED COMPETITION WHICH
MAY NEVER BE USED UPON A PUBLIC ROAD OR HIGHWAY**

INTRODUCTION

Before beginning installation, please read this manual and important notes:

- Please read the installation manual and verify that all items are present. If you are missing hardware or have any questions, please contact your dealer or Whipple.
- **Premium fuel (US 91 octane) is required** to prevent spark-knock/detonation under certain operating conditions. Other countries must meet US 91 octane standards, RON+MON/2. If fuel of less than 91-octane is present in the vehicle fuel tank, the tank must be completely drained and refilled with 91 or higher octane to 1/8th of a tank.
- **91 octane should always be from Tier 1 fuel supplier such as Chevron, Shell, Unocal, Texaco, Sunoco. Bargain fuel (Example: Costco, Safeway, Sam's Club, Vons, Valero) does not perform well and will result in lower power and possible engine damage.**

COMPETITION BASED PRODUCT MAY BE USED SOLELY ON VEHICLES USED IN SANCTIONED COMPETITION WHICH MAY NEVER BE USED UPON A PUBLIC ROAD OR HIGHWAY, UNLESS PERMITTED BY SPECIFIC REGULATORY EXEMPTION (VISIT THE "EMISSIONS" PAGE AT [HTTP://WWW.SEMASAN.COM/EMISSIONS](http://www.semasan.com/emissions) FOR STATE BY STATE DETAILS.

COMPETITION BASED PRODUCT IS LEGAL IN CALIFORNIA ONLY FOR RACING VEHICLES WHICH MAY NEVER BE USED, OR REGISTERED OR LICENSED FOR USE, UPON A HIGHWAY.

IT IS THE RESPONSIBILITY OF THE INSTALLER AND/OR USER OF THIS PRODUCT TO ENSURE THAT IT IS USED IN COMPLIANCE WITH ALL APPLICABLE LAWS AND REGULATIONS.

RECOMMENDED TOOLS AND SUPPLIES

The following items are not included in this supercharger kit and it is strongly recommended that they're used for ease of installation or maximum performance.

Safety glasses, 3/8" torque wrench, 3/8" assorted metric socket set, T40 Torx, trim pad tool (for pushpin removal), floor jack.

PRE-INSTALLATION CHECKLIST

Before installing your Whipple Kit, complete the following checklist.

1. Verify Condition of Vehicle: Before the upgrade kit is installed, ensure the engine runs smoothly and that the factory malfunction indicator light (MIL) is off. Only install the supercharger kit if the engine runs smoothly *and* the MIL is off.
2. **!! CAUTION !!** **This product is intended for use only on STOCK, UNMODIFIED, WELL-MAINTAINED engines. Installation on a worn-out or modified engine is not recommended without factory computer and fuel system modifications. Custom engine configurations are not supported.**
3. Assess Cleanliness of Installation Area: Make sure your work area and the under-hood area are free from debris. This supercharger is a high-quality, close-tolerance compressor and must not be subjected to contamination by dirt or any type of foreign material. If necessary, vacuum around engine to remove any foreign material.
4. **!! CAUTION !!** Identify Kit Components: Before beginning installation, identify all the components of your Whipple Kit and ensure all items are present and undamaged.

SAFETY PRECAUTIONS



CAREFULLY READ THE IMPORTANT SAFETY PRECAUTIONS AND WARNINGS BEFORE PROCEEDING WITH THE INSTALLATION!

Appropriate disassembly, assembly methods and procedures are essential to ensure the personal safety of the individual performing the kit installation. Improper installation due to the failure to correctly follow these instructions could cause personally injury or death. Read each step of the installation manual carefully before starting the installation.

- Always wear safety glasses for eye protection.
- Place the ignition switch in the off position.
- Always apply the parking brake when working on vehicle.
- Block the front and rear tire surfaces to prevent unexpected vehicle movement.
- Operate the engine only in well-ventilated areas to avoid exposure to carbon monoxide.
- Do not smoke or use flammable items near or around fuel system.
- Use chemicals and cleaners only in well-ventilated areas.
- Batteries can produce explosive hydrogen gas which can cause personal injury. Do not allow flames, sparks or flammable sources to come near the battery.
- Keep hands and any other objects away from the radiator fan blades.
- Keep yourself and your clothing away from moving parts when the engine is running.
- Do not wear loose clothing or jewelry that can be caught in rotating or moving parts.



****NOTICE:** Installation of Whipple products signifies that you have read this document and have agreed to the terms stated within.

It's the purchaser's responsibility to follow all installation instruction guidelines and safety procedures supplied with the product as it's received by the purchaser to determine the compatibility of the product with the vehicle or the device the purchaser intends to install the product on.

Whipple assumes no responsibility for damages occurring from accident, misuse, abuse, improper installation, improper operation, lack of reasonable care or all previously stated reasons resulting from incompatibility with other manufacturer's products.

There are no warranties expressed or implied for engine failure or damage to the vehicle in any way, loss of use or inconvenience or labor reimbursement. This includes merchantability and fitness.

The information contained in this publication was accurate and in effect at the time the publication was approved for printing and is subject to change without notice or liability. Whipple reserves the right to revise the information presented herein or to discontinue the production of parts described at any time.

PCM CALIBRAITON NOTICE

Your Whipple Performance kit includes a PCM reflash. You must follow the included Tomahawk Flash Tool instructions to request your calibration. NOTE: Whipple does not offer custom tuning. **Calibrations are provided for 100% stock vehicles with an exception to cat-back exhaust systems. Long tube headers, high flow cats and other engine mods are not supported. Calibrations can take up to 48 hours to fulfill, request before starting installation.**

INSTALLATION INSTRUCTIONS

It is strongly recommended that you read through this guide **before** you begin installing the Whipple Kit.

1. Follow the supplied instructions for the Tomahawk flash tool. Please allow up to 48 hours for calibration. **NOTE:** Vehicle will run with the parts installed prior to calibration if needed.
2. Using an air hose, blow off any loose dirt or debris from engine compartment. If really dirty, then steam clean the engine compartment before proceeding to the next step.
3. Lift the vehicle using a floor hoist, if you do not have access to one, use a hydraulic floor jack and jack stands to raise the vehicle. **NOTE:** Jack stands must be used on a level surface and be securely seated. Failure to do so may result in personal injury or vehicle damage.

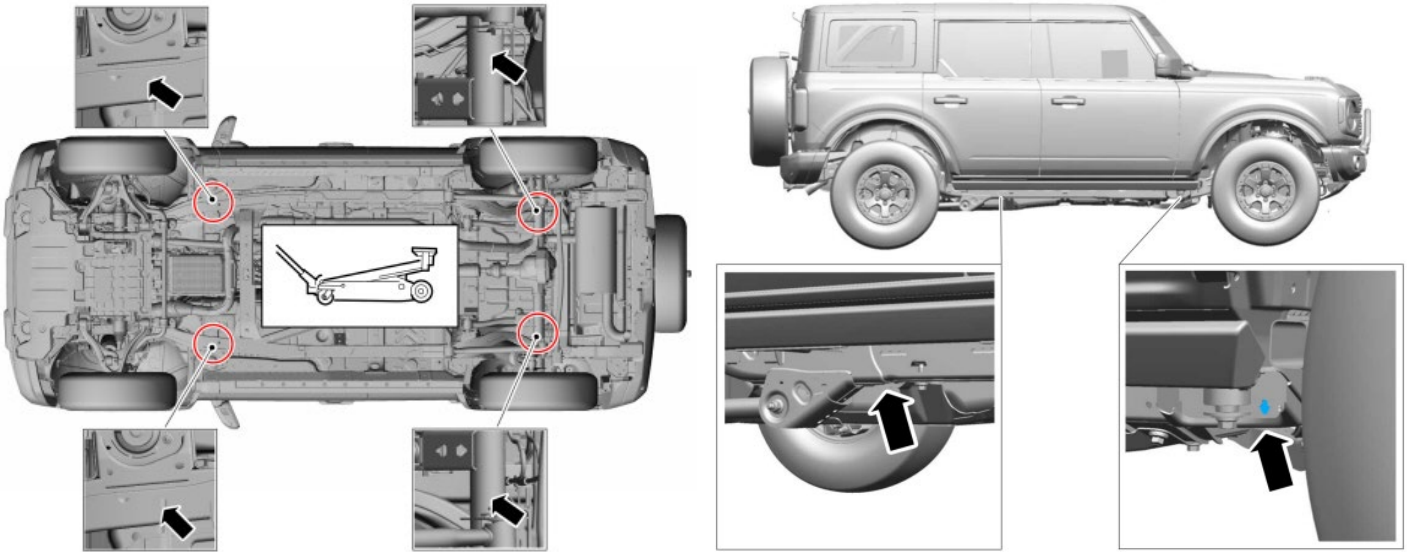

4. Remove the fasteners and the engine front under shield using 15mm socket. **NOTE:** Some models have (4), some have (6).

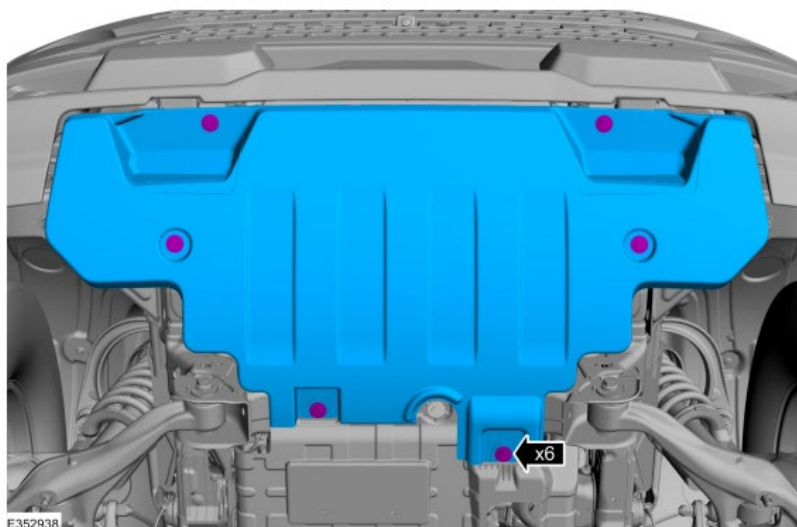

E352938

5. Release the CAC inlet pipe by spreading the retainer ends outward. Position the retainer ends in the notches locking the retainer in the open position and position aside the CAC inlet pipe.

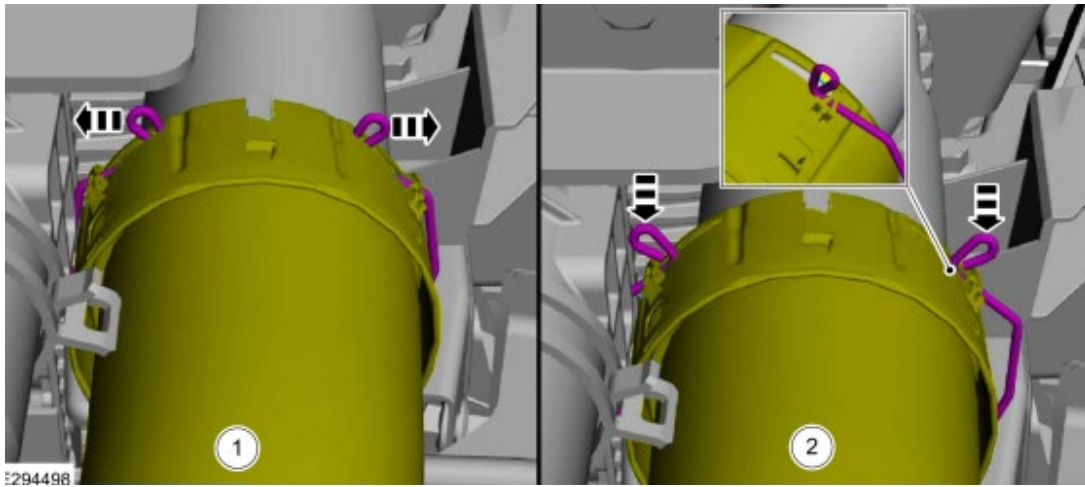

6. Release the CAC outlet pipe by spreading the retainer ends outward. Position the retainer ends in the notches locking the retainer in the open position and position aside the CAC outlet pipe.

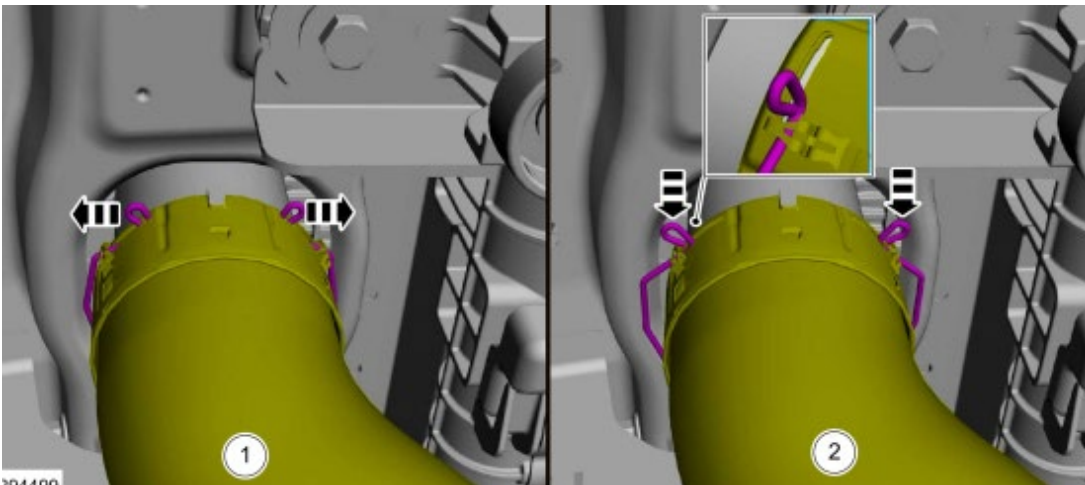

7. Disconnect the front bumper electrical connector (LH front of vehicle).

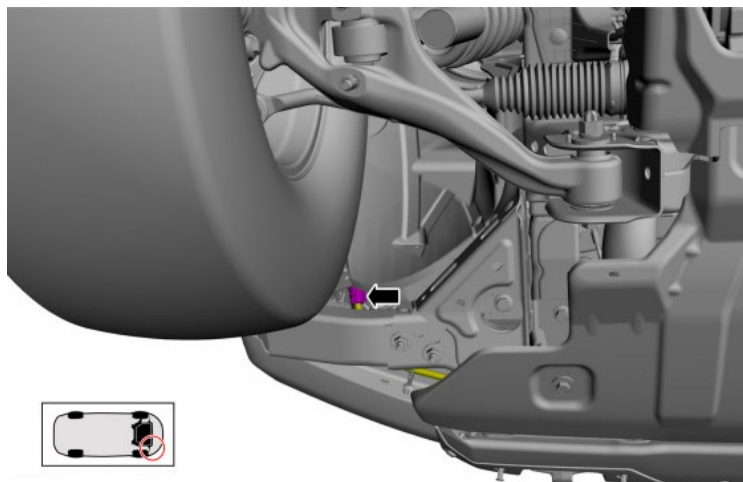

8. If equipped, remove the bolts and front bumper bar using a T40 socket.

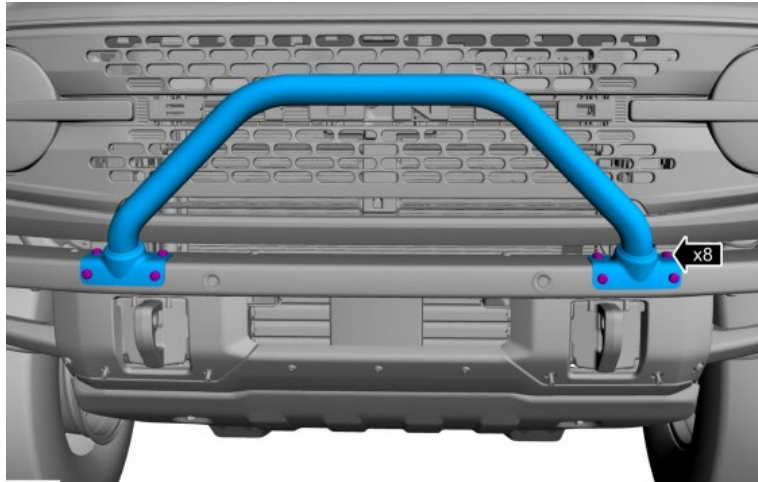

9. Remove the push pins, release the clips and remove the front bumper trim panel.

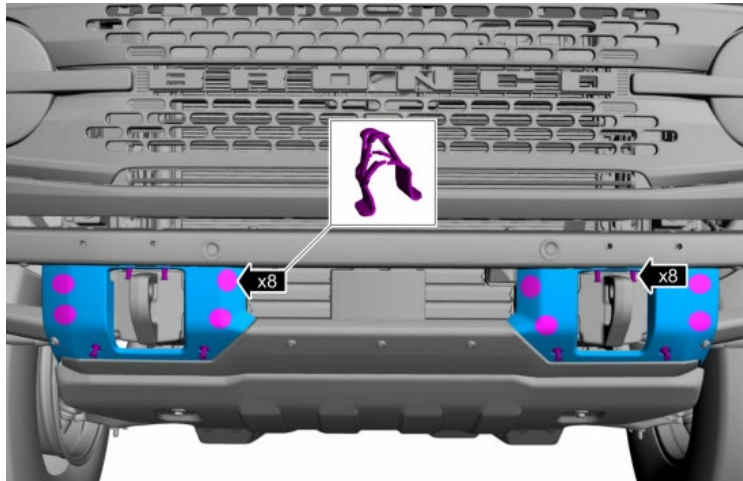

10. Remove the bolts and the front bumper using a 15mm socket.

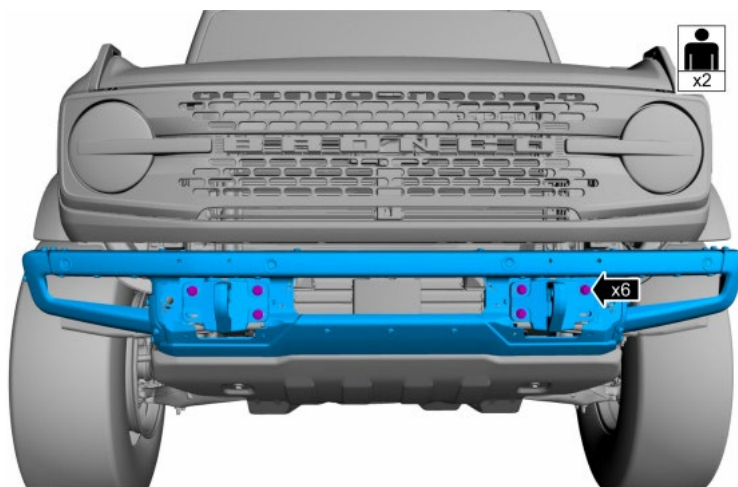

11. Release the CCM cover top clips and remove cover.

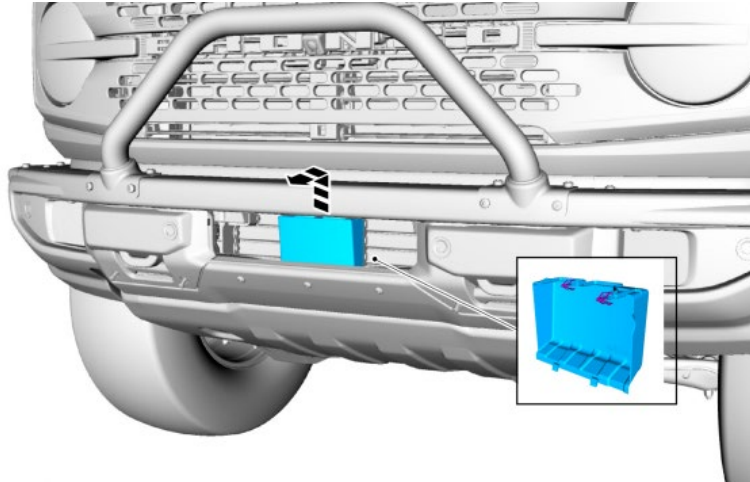

12. Disconnect the lower active grill shutter actuator electrical connector.

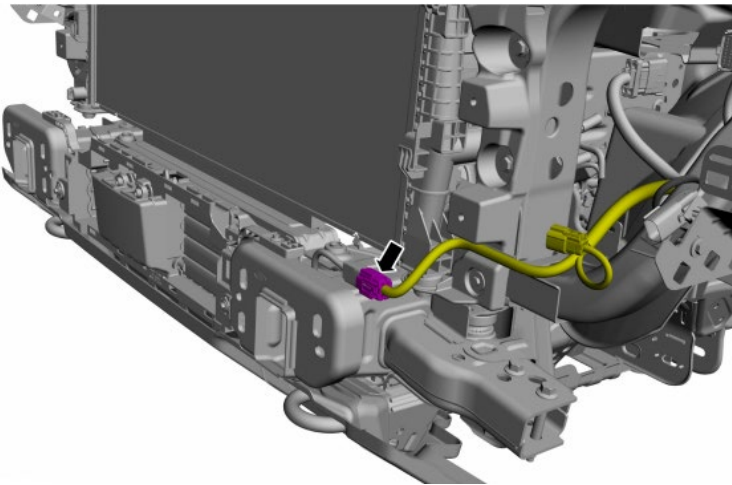

13. Remove the (4) bolts and the lower active grille shutter unit using 8mm socket.

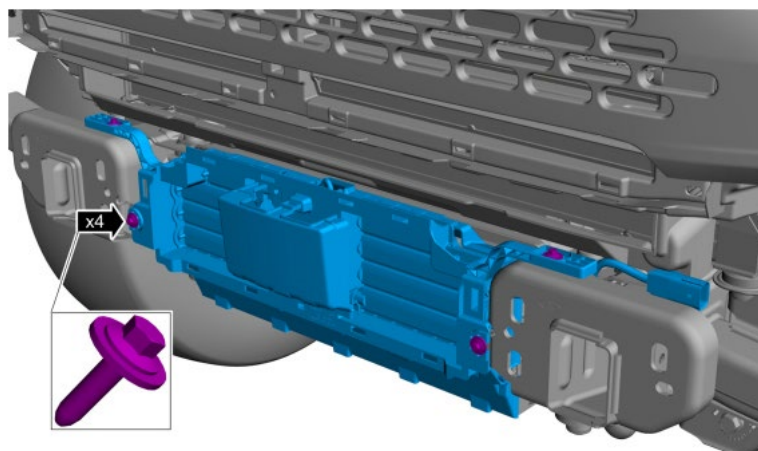

14. If equipped, remove the tow hook shields.

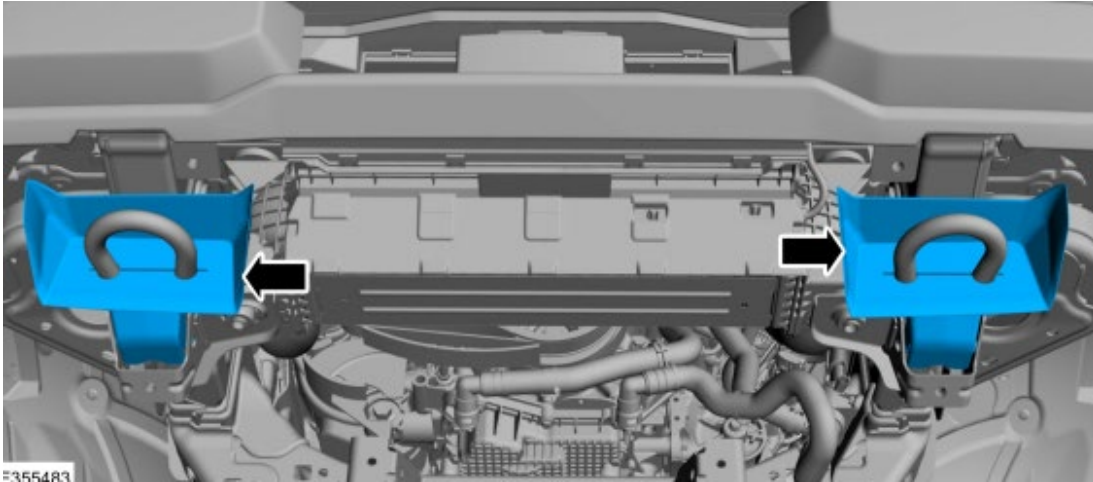

15. Gently release the CCM grommets from the active grille shutter CCM bracket, then remove CCM from bracket. Disconnect CCM wiring connector from CCM. NOTE: If not equipped with CCM, disregard.

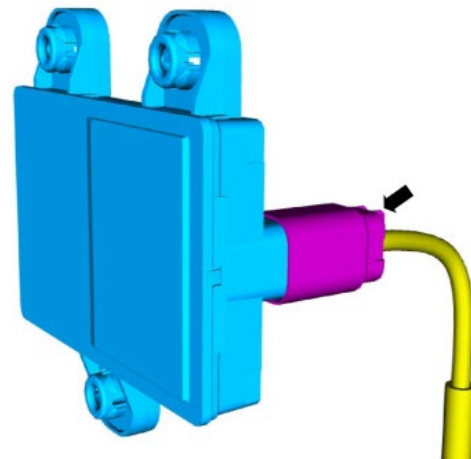
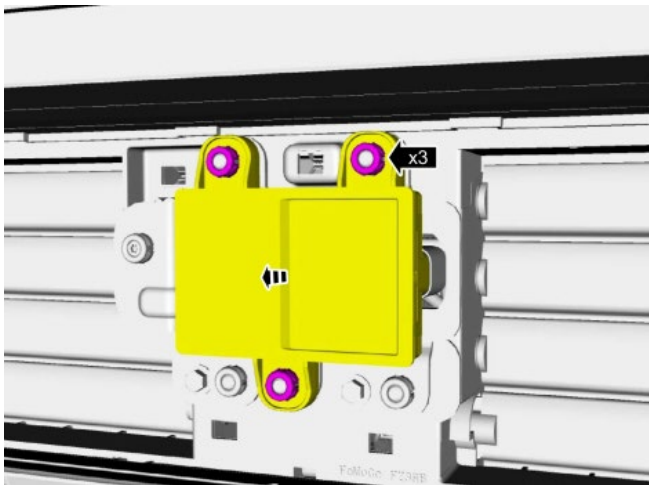

16. With the aid of a 2nd person, remove (4) bolts from the CAC/tow hook brackets to lower CAC out of vehicle.

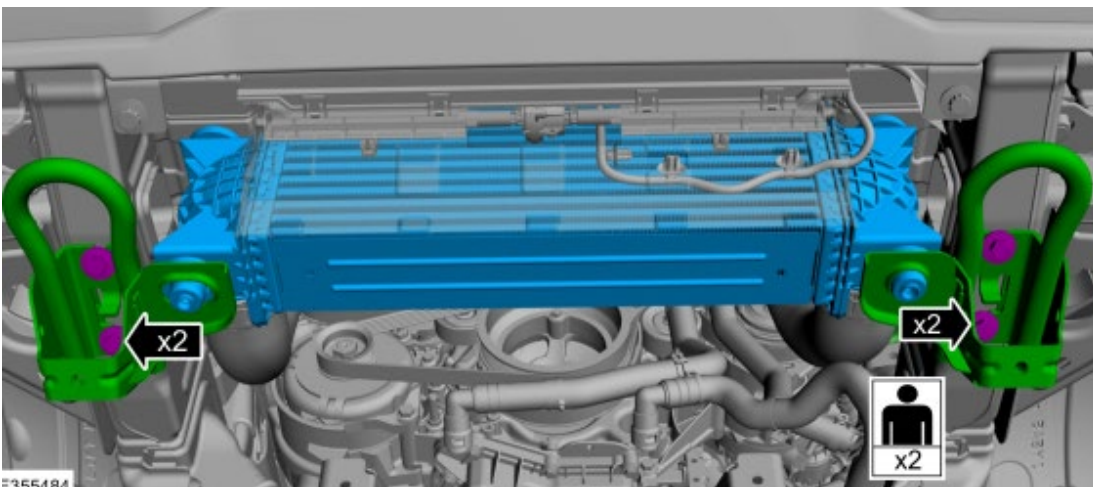

17. Remove the CAC isolators from CAC. Transfer to new CAC.

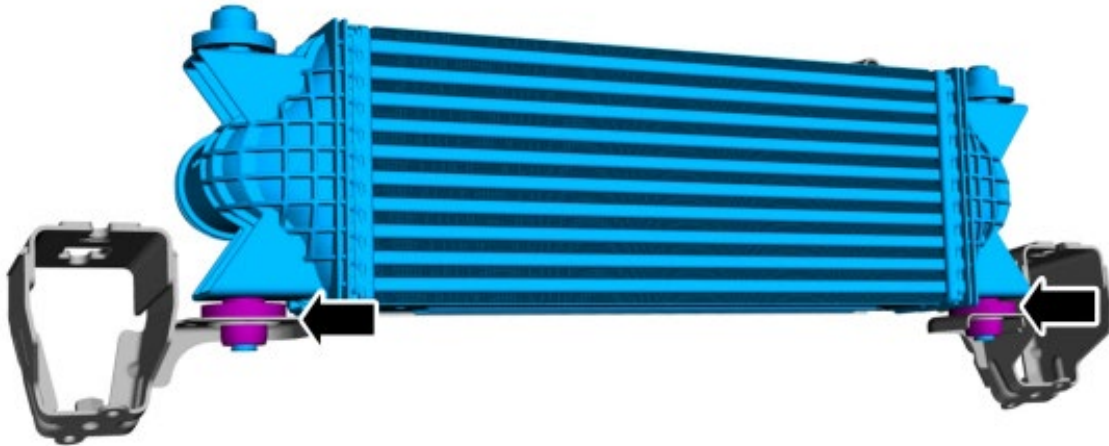

18. (If equipped) Remove the (1) bolt and dislodge the holding clips. Using factory bolt, transfer to new CAC. Torque to 62 in-lbs.

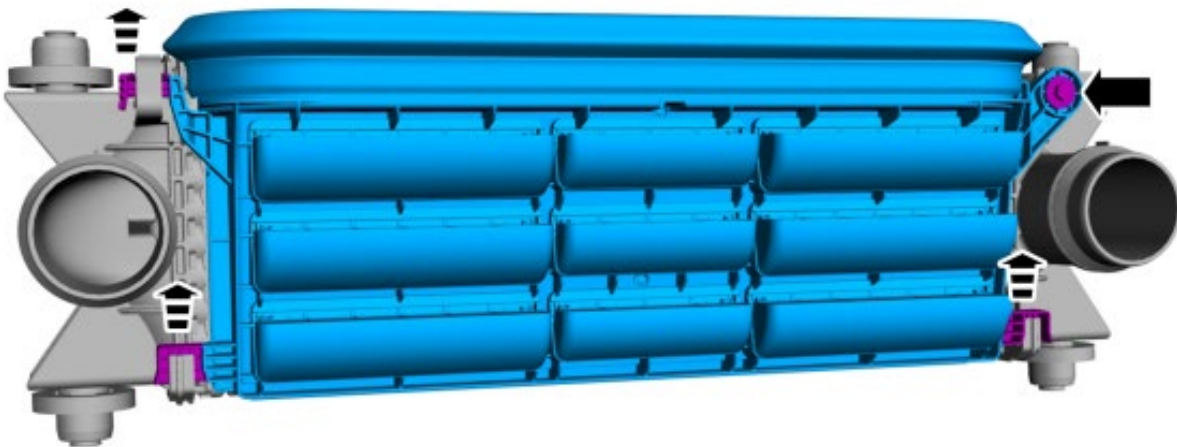

19. Set CAC to stock brackets. With the aid of a 2nd person, install the (4) bolts from the IC/tow hook brackets to install CAC. Torque to 59 ft-lb.

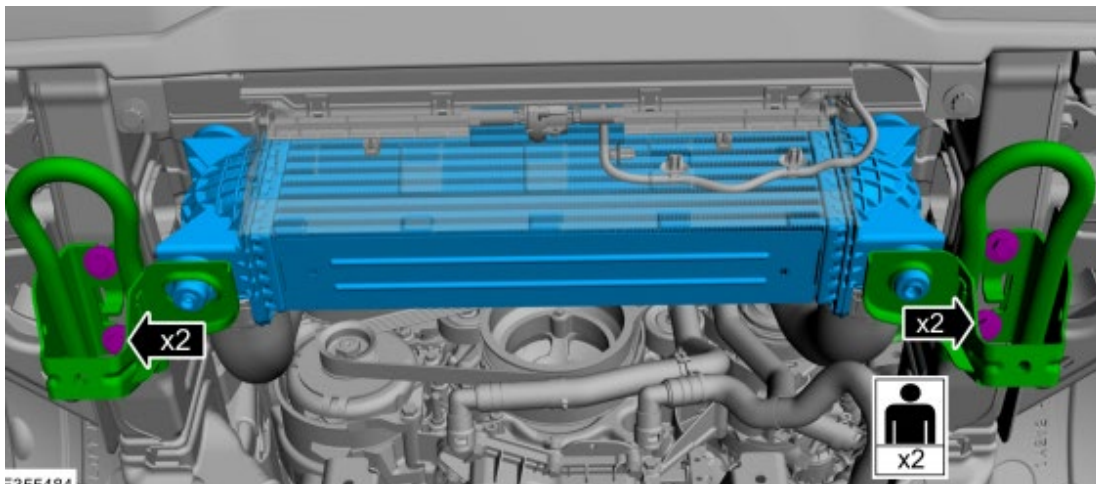

20. Remove the CCM bracket from active grill shutter using an 8mm socket. Transfer CCM bracket to supplied CCM bracket assembly using the (3) 6mm x 10mm HHFCS fasteners. Torque to 96 in-lb using a 10mm socket. Slide CCM module back on bracket. **NOTE:** CCM bracket is pre-positioned and should not require adjustment, CCM equipped vehicles should never modify CCM bracket or fasteners. The CCM bracket can be discarded if vehicle is not equipped with CCM.

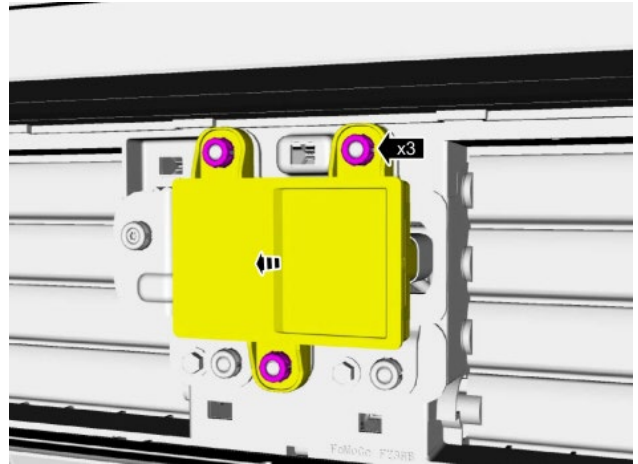
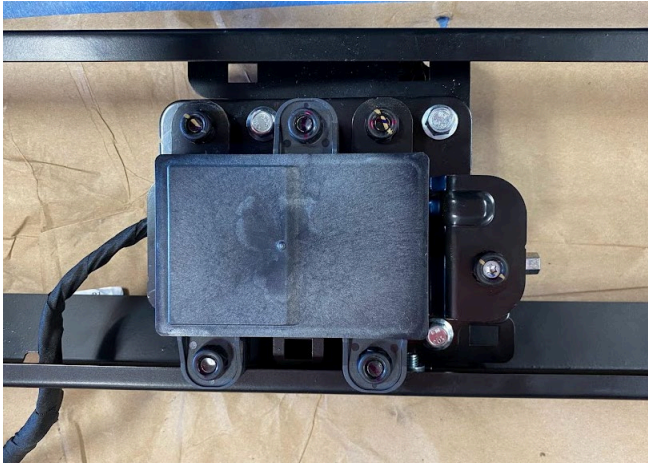

21. Remove the active grille shutter motor from assembly by remove U-shape brace, then removing shutter arms from motor. Install on new supplied bracket using the (2) supplied zip-ties.



22. Mount the shutter motor to the bracket assembly using the (2) supplied zip-ties. Secure CCM wiring using same zip ties for a clean installation.

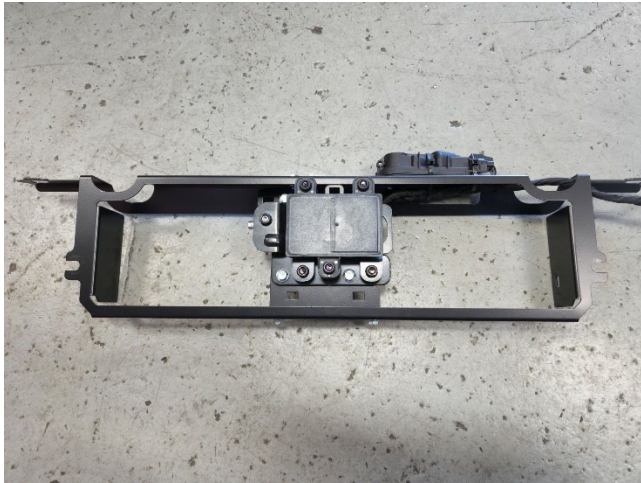

23. Install the new CCM bracket assembly to vehicle using the (4) factory fasteners. Torque to 62 in-lb using 8mm socket.



24. Reconnect CCM wiring connector to CCM. Reinstall plastic cover over CCM bracket, this will **NOT** fit after bumper installation.

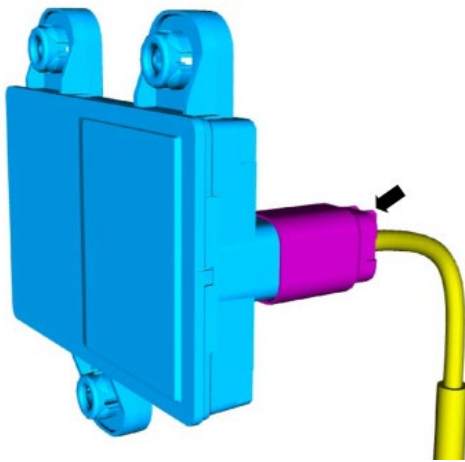

25. Reconnect the lower active grill shutter actuator electrical connector.

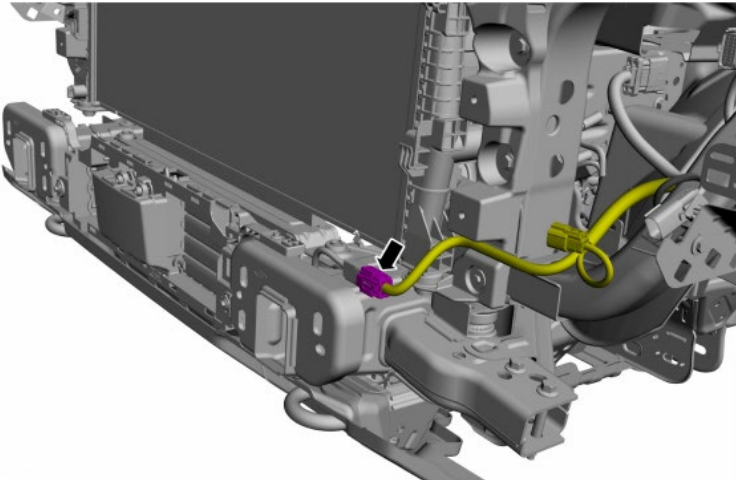

26. Install the stock bolts and the front bumper using a 15mm socket, torque to 81 ft-lb.

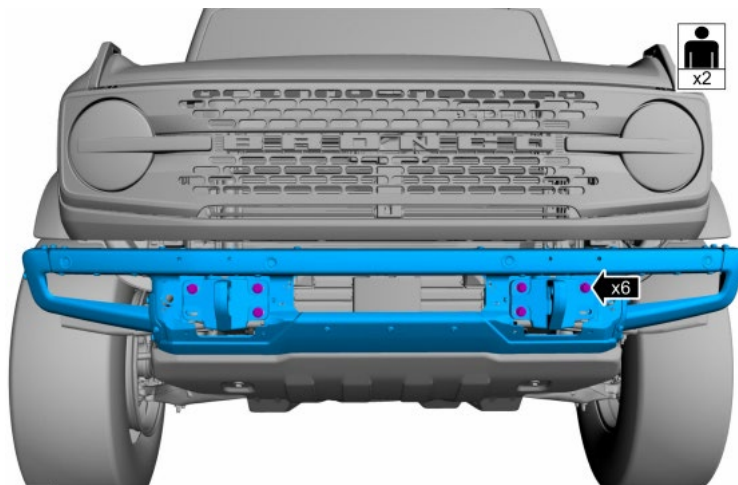

27. Reinstall the push pins and front bumper trim panel.

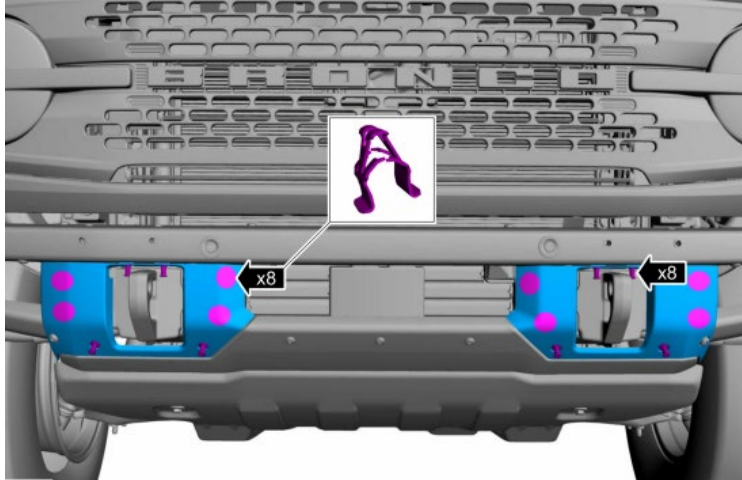

28. Reinstall the front bumper bar with the factory (8) bolts using a T40 socket. Torque to 25 ft-lb.

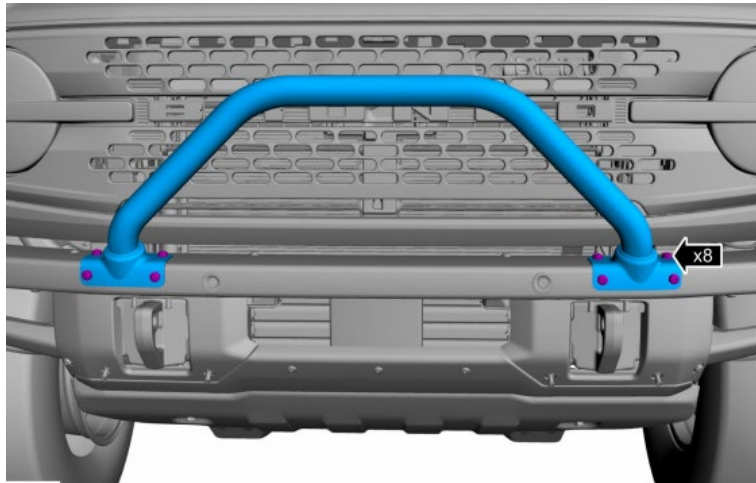

29. Reconnect the front bumper electrical connector.

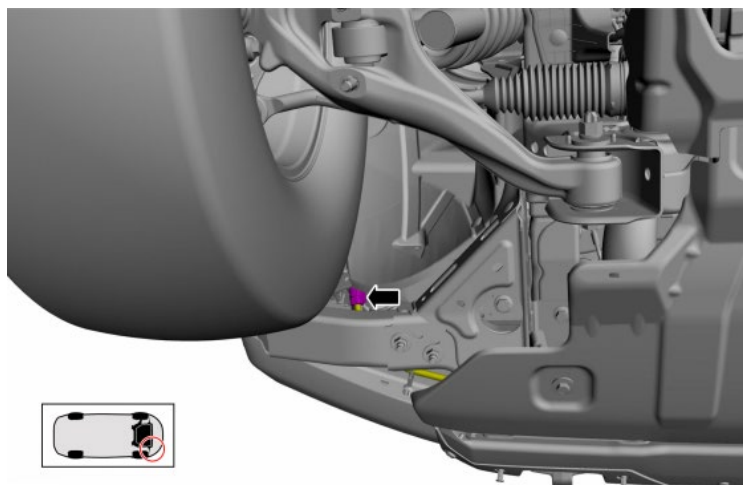

30. Reinstall the fasteners and the engine front under shield. Torque to 124 in-lbs.

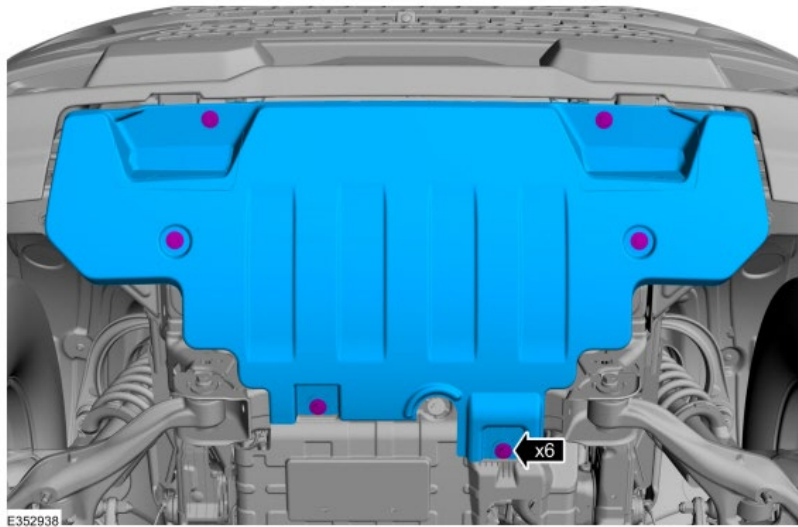

31. Remove the fastener and the air intake duct.

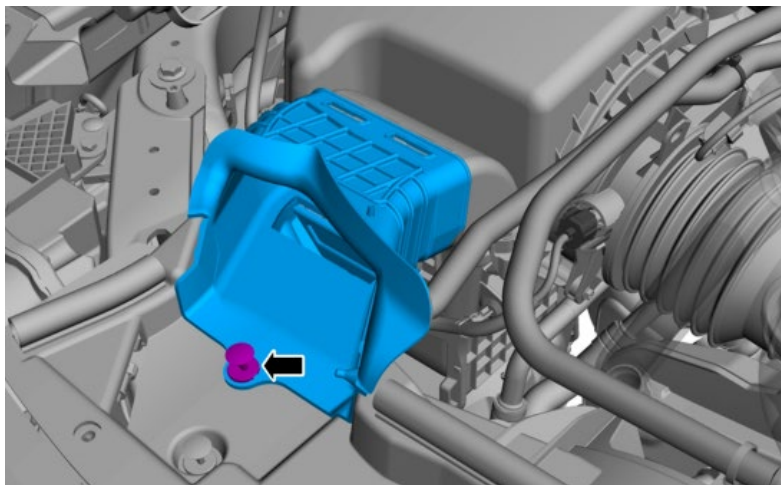

32. Remove the 4 bolts securing airbox lid to airbox. Remove stock filter by lifting up and away.



33. Install filter in place, ensure it secures to box and can't come loose.



34. Install the CARB legal decal next to the OEM emission decal located under the hood. Install the 91 octane decal in the gas door.
35. Start the vehicle, check for any leaks or check engine lights. Ensure you have 91 octane or higher fuel.
36. **NOTE:** If the CCM (cruise control module) needs to be aligned, perform the cruise control radar alignment procedure before the front bumper is installed. Using a diagnostic scan tool, complete the PMI process for the CCM following the on-screen instructions.

CCM ALIGNMENT IF REQUIRED

37. Place the vehicle on a wheel alignment bay station. Locate the CCM alignment screw.

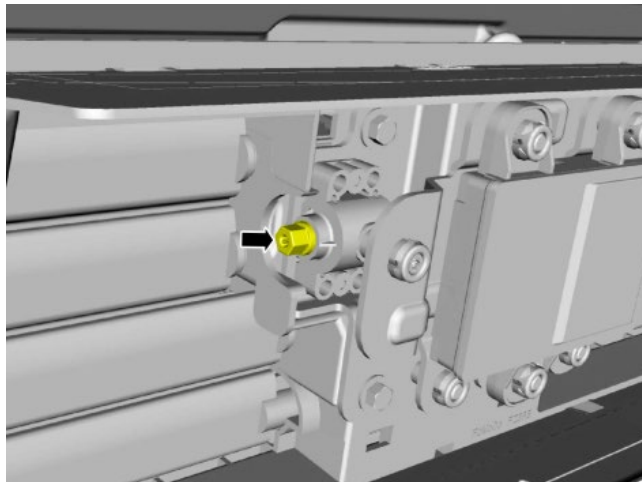

38. **NOTE:** Measurement must be taken from the non-raised side of the CCM. Place a combination square level on the face of the CCM and check the alignment.

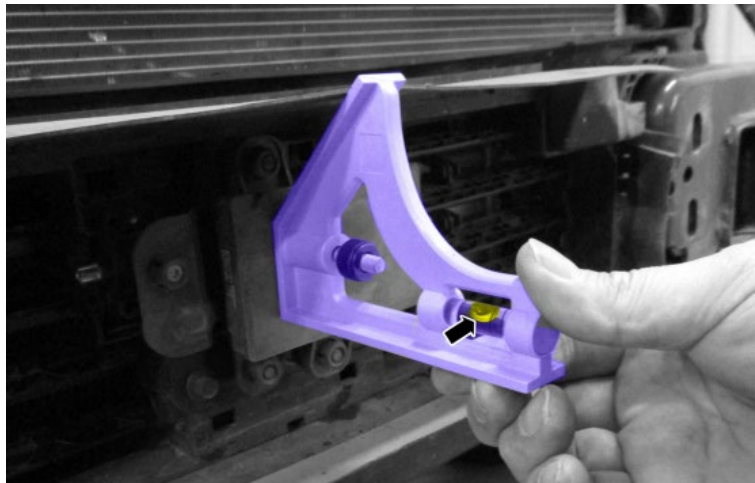

39. **NOTE:** Measurement must be taken from the non-raised side of the CCM. Keeping the combination square level on the face of the CCM, adjust the pitch by turning the adjustment screw until the CCM is vertical and level.

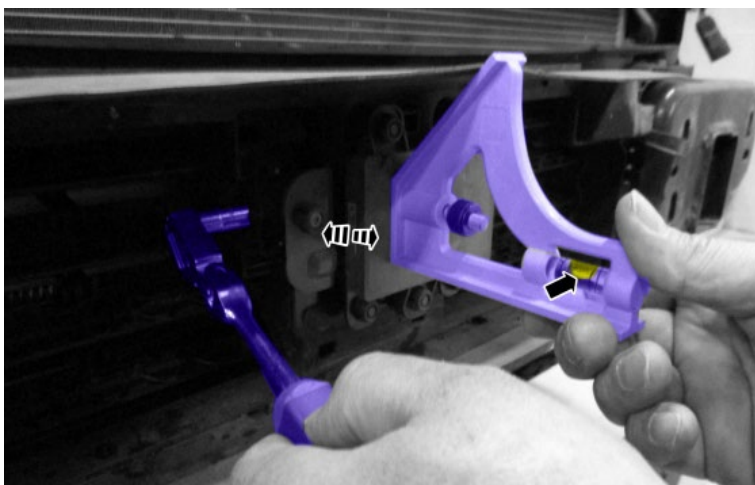

40. **NOTE:** The horizontal alignment for the CCM (cruise control module) is a software calibration check that is performed by the scan tool to insure the CCM (cruise control module) radar is pointed straight. No manual adjustment is needed for this procedure. The scan tool calibrates the CCM (cruise control module) through the CCM (cruise control module) procedure in programmable parameters. The Alignment Offset specification is +/- 3.0 degrees of offset. **NOTICE: The vehicle's engine must be running during the horizontal alignment procedure. Failure to leave the engine running throughout the entire procedure results in the cancellation of the alignment procedure and the system remains non-functional.**

41. Follow the scan tool on-screen instructions to carry-out the CCM calibration procedure.

IMPORTANT INFORMATION

BOOST LEVELS

All Whipple kits are shipped with boost levels that Whipple feels achieves maximum power while maintaining reliability with stock engines (@ sea level). Additional boost controllers cannot be added. Aftermarket wastegates are not supported.

EXHAUST

Cat-back exhaust systems help reduce heat and minimize exhaust back pressure. They do not affect the calibration and are always a good idea for added safety and performance. Long tube headers and/or high flow cats are not supported and are not legal by Whipple.

FUEL OCTANE

Never run a fuel octane that is below 91octane, $(RON+MON)/2$ and never run fuel with more volume than 10% Ethanol. It is recommended, when available, to run 92-94 octane. Never mix mid-level (below 91) with 91+, this is very dangerous and can cause severe engine damage. Do not attempt to increase octane ratings with generic octane boosters, these are very hard on spark plugs and many brands do very little to the actual octane rating (1 point is .1 octane). The PCM constantly adapts, if it senses better fuel, it will increase power accordingly.

Not all fuel is equal. Tier 1 type fuel such as Chevron, Shell, Unocal, Texaco, Sunoco, BP, Mobil, Phillips are highly recommended. Second rate "bargain" fuel from grocery stores and other vendors should always be avoided. Whipple testing has shown high risk when running premium fuel from places such as Costco, Vons, etc.