

WHIPPLE

2020-2021 2.3L/3.0L ECOBOOST FORD EXPLORER ST/LINCOLN AVAITOR STAGE 1 INSTALLATION MANUAL **PN #WK-8170, WK-8175**



WHIPPLE SUPERCHARGERS
3292 NORTH WEBER AVE
FRESNO, CA 93722
TEL 559.442.1261
FAX 559.442.4153

www.whipplesuperchargers.com

*A color PDF of this manual is available, email
tech@whipplesuperchargers.com for a copy*

PREMIUM FUEL ONLY (91 OCTANE OR BETTER ALWAYS) RON+MON/2

CARB EO #PENDING

INTRODUCTION

- Please read the installation manual and verify that all items are present. If you are missing hardware or have any questions, please contact your dealer or Whipple.
- COMPETITION BASED PRODUCT MAY BE USED SOLELY ON VEHICLES USED IN SANCTIONED COMPETITION WHICH MAY NEVER BE USED UPON A PUBLIC ROAD OR HIGHWAY, UNLESS PERMITTED BY SPECIFIC REGULATORY EXEMPTION (VISIT THE "EMISSIONS" PAGE AT [HTTP://WWW.SEMASAN.COM/EMISSIONS](http://www.semasan.com/emissions) FOR STATE BY STATE DETAILS.
- COMPETITION BASED PRODUCT IS LEGAL IN CALIFORNIA ONLY FOR RACING VEHICLES WHICH MAY NEVER BE USED, OR REGISTERED OR LICENSED FOR USE, UPON A HIGHWAY.
- IT IS THE RESPONSIBILITY OF THE INSTALLER AND/OR USER OF THIS PRODUCT TO ENSURE THAT IT IS USED IN COMPLIANCE WITH ALL APPLICABLE LAWS AND REGULATIONS.

ITEM NO.	DESCRIPTION	QTY.
1	3.0L ECOBOOST INTERCOOLER	1
2	3.0L ECOBOOST HE BRACKET - UPPER LEFT	1
3	3.0L ECOBOOST HE BRACKET - UPPER RIGHT	1
4	3.0L ECOBOOST HE BRACKET - RIGHT	1
5	3.0L ECOBOOST HE BRACKET - LEFT	1
6	2020 ECOBOOST SHIPPING BOLT BAG	1
6.1	M6 X 1.00 X 16MM HHFCS 10.9 ZP	9
7	NYLON SHAFT GROMMET 7/16" HOLE DIAMETER	2
8	Ø11.8MM TO 1/4" MNPT QDC	1

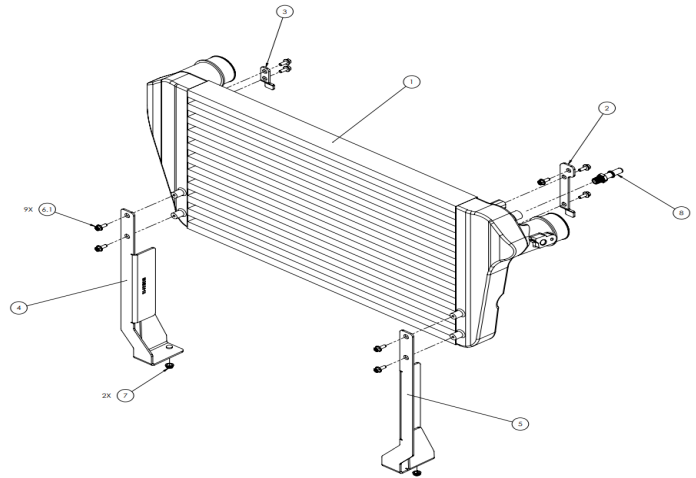

SAFETY PRECAUTIONS



CAREFULLY READ THE IMPORTANT SAFETY PRECAUTIONS AND WARNINGS BEFORE PROCEEDING WITH THE INSTALLATION!

Appropriate disassembly, assembly methods and procedures are essential to ensure the personal safety of the individual performing the kit installation. Improper installation due to the failure to correctly follow these instructions could cause personally injury or death. Read each step of the installation manual carefully before starting the installation.

- Always wear safety glasses for eye protection.
- Place the ignition switch in the off position.
- Always apply the parking brake when working on vehicle.
- Block the front and rear tire surfaces to prevent unexpected vehicle movement.
- Operate the engine only in well-ventilated areas to avoid exposure to carbon monoxide.
- Do not smoke or use flammable items near or around fuel system.
- Use chemicals and cleaners only in well-ventilated areas.
- Batteries can produce explosive hydrogen gas which can cause personal injury. Do not allow flames, sparks or flammable sources to come near the battery.
- Keep hands and any other objects away from the radiator fan blades.
- Keep yourself and your clothing away from moving parts when the engine is running.
- Do not wear loose clothing or jewelry that can be caught in rotating or moving parts.



****NOTICE:** Installation of Whipple products signifies that you have read this document and have agreed to the terms stated within.

It's the purchaser's responsibility to follow all installation instruction guidelines and safety procedures supplied with the product as it's received by the purchaser to determine the compatibility of the product with the vehicle or the device the purchaser intends to install the product on.

Whipple assumes no responsibility for damages occurring from accident, misuse, abuse, improper installation, improper operation, lack of reasonable care or all previously stated reasons resulting from incompatibility with other manufacturer's products.

There are no warranties expressed or implied for engine failure or damage to the vehicle in any way, loss of use or inconvenience or labor reimbursement. This includes merchantability and fitness.

The information contained in this publication was accurate and in effect at the time the publication was approved for printing and is subject to change without notice or liability. Whipple reserves the right to revise the information presented herein or to discontinue the production of parts described at any time.

PCM CALIBRAITON NOTICE

Your Whipple Performance kit includes a PCM reflash. You must follow the included Flash Tool instructions to request your calibration. NOTE: Whipple does not offer custom tuning. **Calibrations are provided for 100% stock vehicles with an exception to cat-back exhaust systems. Long tube headers, high flow cats and other engine mods are not supported. Calibrations can take up to 48 hours to fulfill, request before starting installation.**

INSTALLATION INSTRUCTIONS

It is strongly recommended that you read through this guide **before** you begin modifying your vehicle.

1. Disconnect the (-) negative cable from the battery, secure ground wire so it cannot arc.
2. Disconnect the front inner fender from front fascia by removing the (4) fasteners with a 7mm socket and (4) push pins per side.



3. Remove the lower bumper cover by removing the (11) bolts using a 7mm socket.

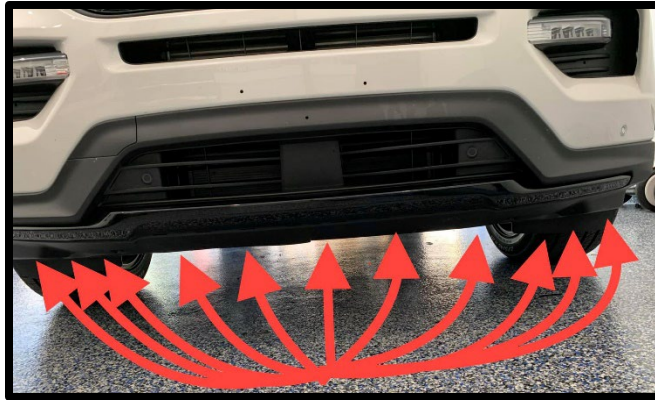

4. Remove the fender trim from front fenders.



5. Disconnect the (2) proximity sensors and the (2) 7mm bolt under proximity sensor (per side).



6. Remove the (2) bolts holding the bumper cover to front fender using a 10mm socket.

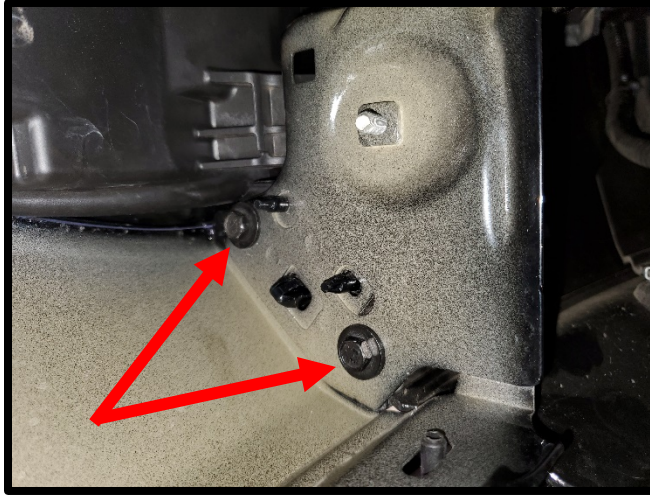

7. Remove the (4) 10mm bolts from front upper grill.

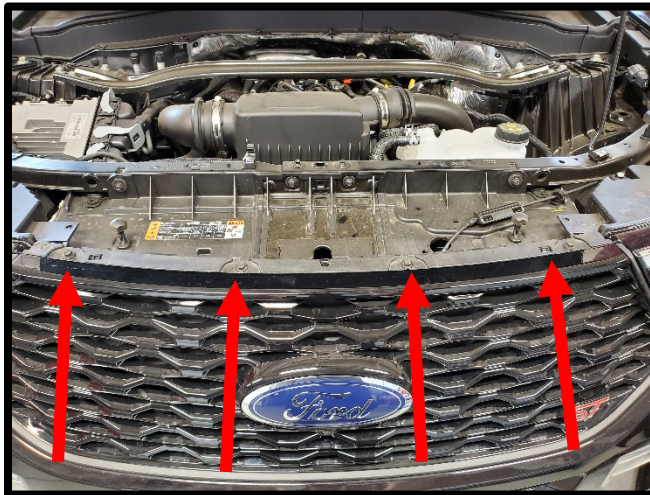

8. Unplug front camera and disconnect camera washer line from junction.



9. Unplug the black 4-way connector next to camera connector.

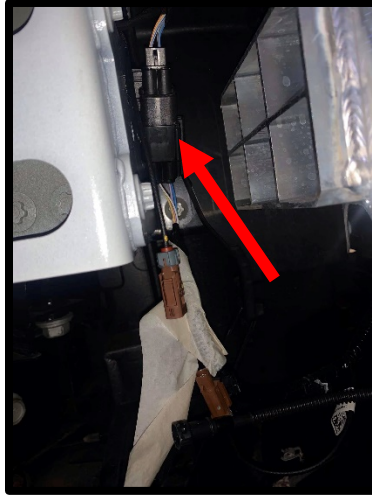

10. Unplug the headlight harness connectors and the TMAP sensor connector from intercooler.



11. Disconnect electrical connector by releasing the gray tab.



12. Lift the upper grill area to release and remove from vehicle.
13. Remove the (5) 10mm bolts from each headlight and remove headlights from vehicle.

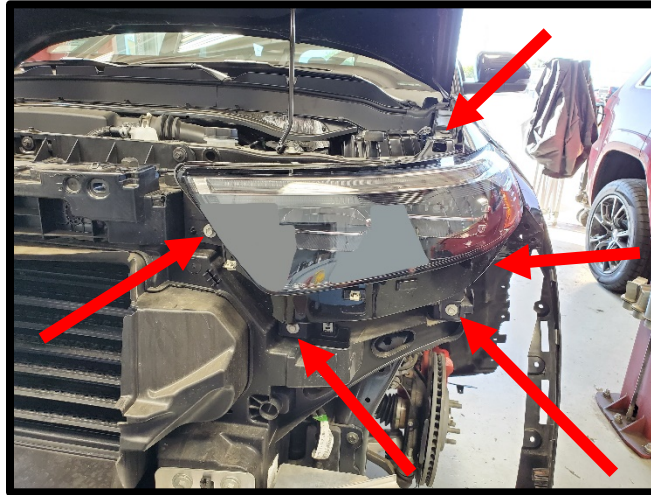

14. Unclip the hood release cable from factory bracket.

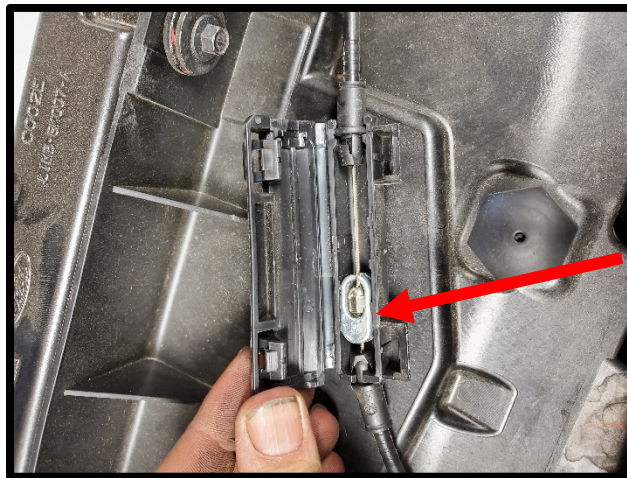

15. Remove the (8) bolts and remove the bumper crash bar using a 13mm socket.

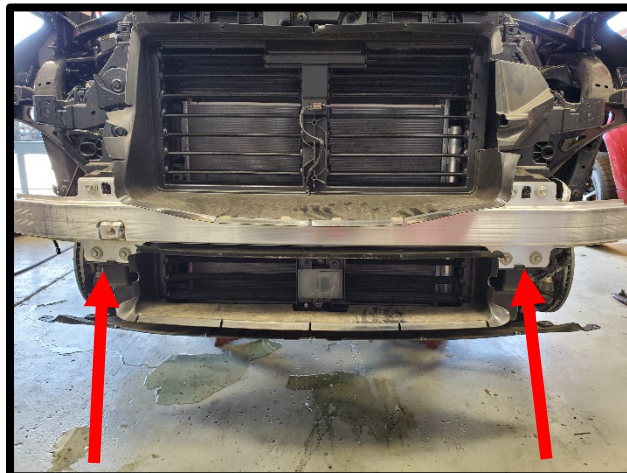

16. Remove the (5) bolts from lower bumper supports using the 10mm bolts.



17. Cut the factory (4) zip-ties.



18. Remove the (4) bolts from upper shroud using an 8mm socket.

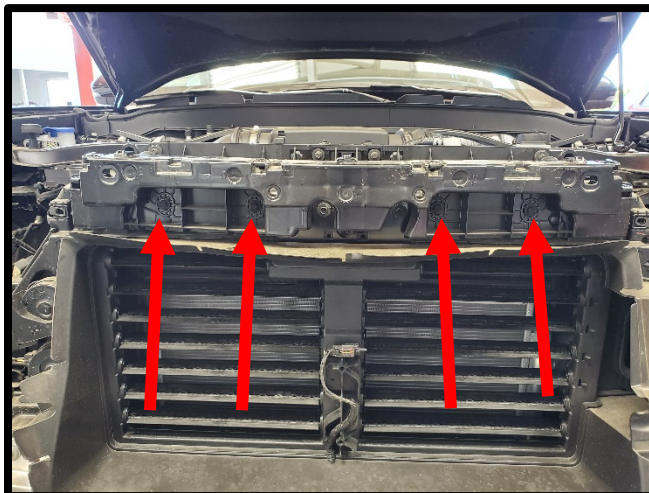

19. Disconnect the quick connect fitting from the stock IC outlet tank and disconnect TMAP sensor 4-way connector.

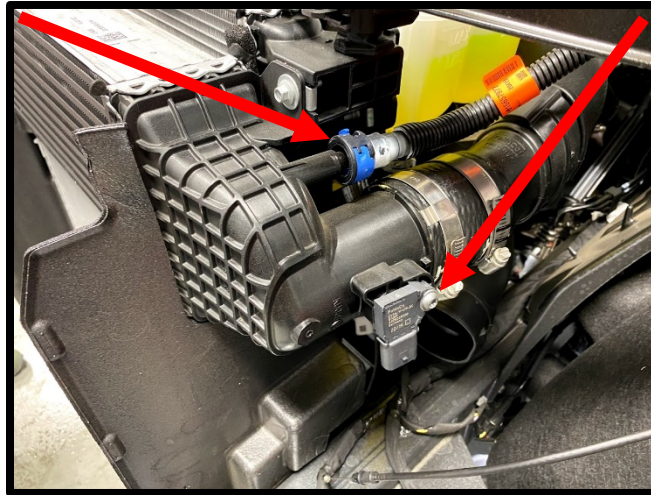

20. Loosen the intercooler clamps on the inlet and outlet connection hoses.

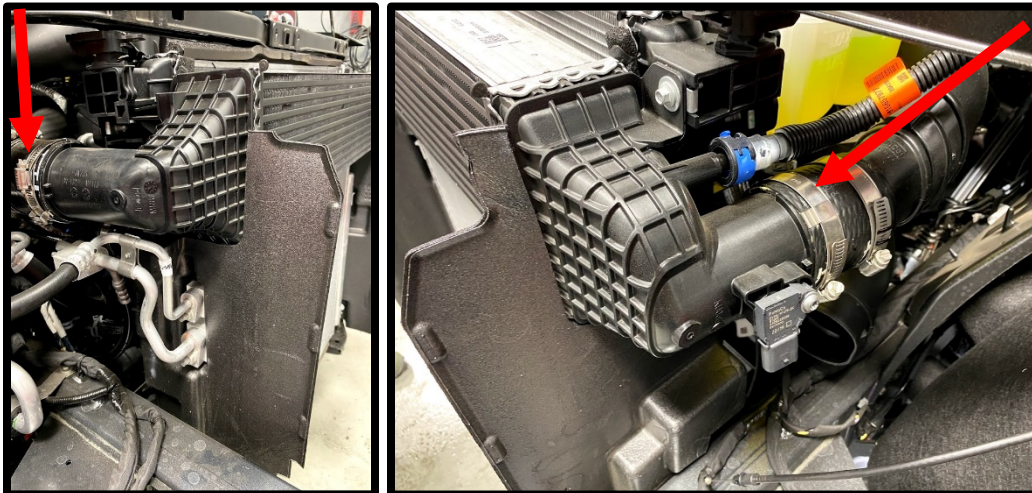

21. Remove the factory bolt from the IC mount flange using a 10mm socket. Lift intercooler up and away from vehicle.

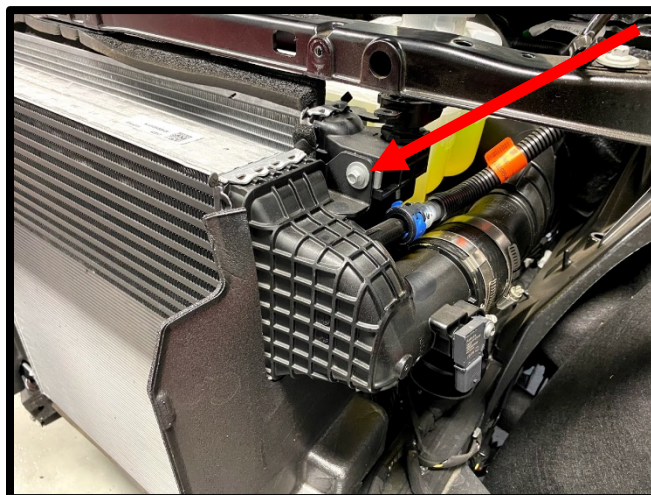

22. Remove the TMAP sensor from the stock intercooler using a Torx 30. Transfer this to the Whipple intercooler outlet tank, apply Blue Loctite to threads of supplied 6mm x 16mm HHFCS bolt.

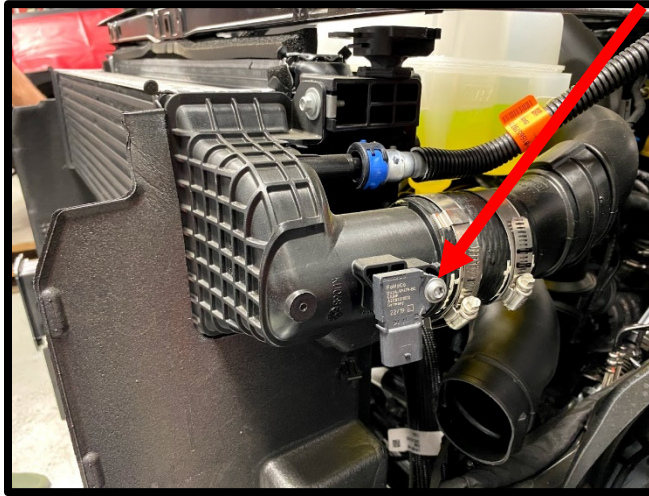

23. Apply thread sealant to the 1/4" NPT to quick connect fitting. Install into Whipple intercooler outlet tank using a 3/4" wrench.

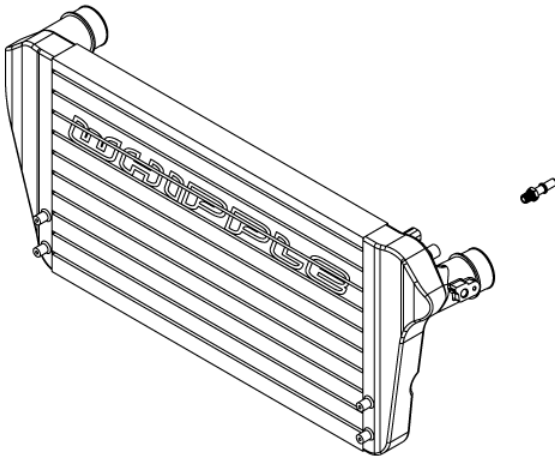

24. Install the (2) mounting brackets to the Whipple IC using the (2 per side) 6mm x 16mm HHFCS bolts. Apply light amount of Blue Loctite to threads.

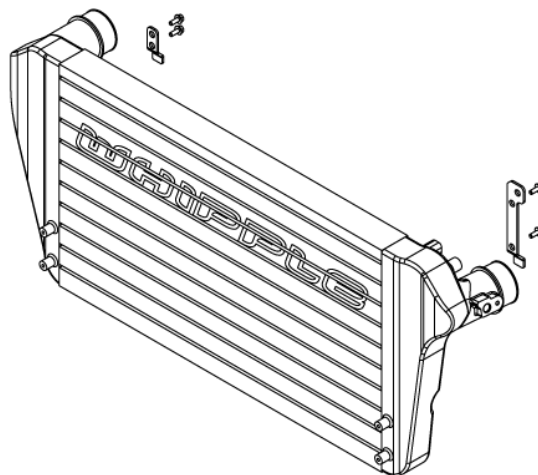

25. Mount Whipple IC to vehicle by setting the (2) rear support brackets into factory locations. Secure upper driver side bracket with factory bolt previously removed. Secure inlet/outlet tanks to factory hose connections using factory clamps.

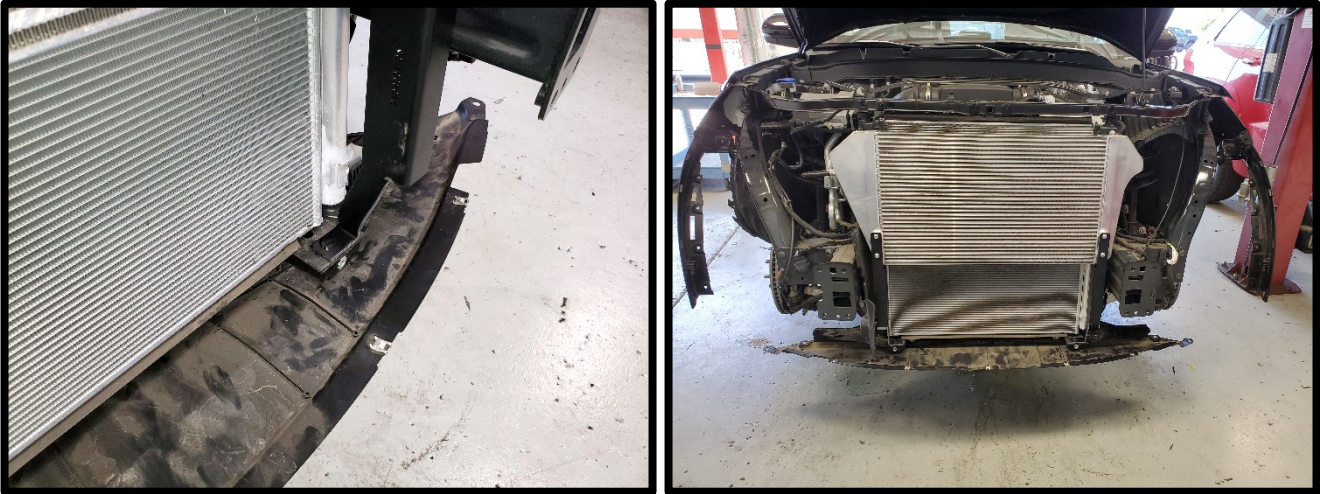

26. Install the (2) lower support brackets by setting into position on the factory frame. Secure brackets to front of intercooler using the supplied (4) 6mm x 16mm FFHCS bolts. Apply light amount of Blue Loctite to threads.

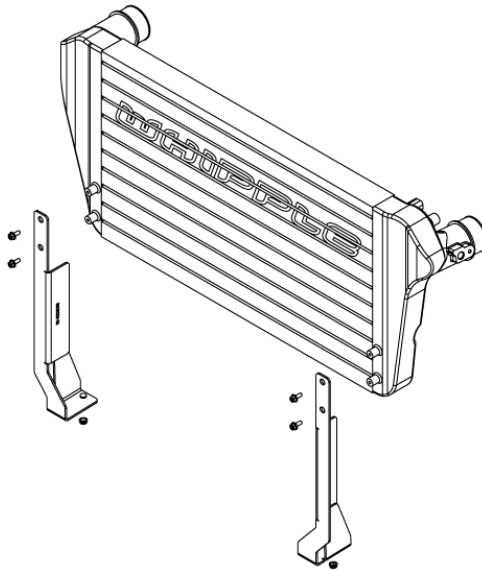

27. Replace the (4) zip-ties that you previously cut.
28. Reverse all steps of removal to reassemble the vehicle to reinstall vehicle.
29. Lift factory airbox lid by releasing clamps, install the supplied high flow filter and reinstall airbox.