



WHIPPLE FUEL PUMP BOOSTER INSTALL MANUAL

2018-2022 CHRYSLER/DODGE 5.7 ENGINE



WHIPPLE SUPERCHARGERS

3292 NORTH WEBER AVE

FRESNO, CA 93722

TEL 559.442.1261

FAX 559.442.4153

WWW.WHIPPLESUPERCHARGERS.COM

PREMIUM FUEL ONLY (91 OCTANE OR BETTER ALWAYS) RON+MON/2

⊗ NEVER SMOKE DURING THE INSTALLATION OF THE SC, THERE WILL BE FLAMMABLE FUMES AND LIQUID AROUND THE VEHICLE

INTRODUCTION

Before beginning installation, we encourage you to read this manual thoroughly before you begin any portion of the installation:

1. A quick parts check to make certain your kit is complete (see shipper parts list in packing paperwork). If you discover shipping damage or shortage, please call our office immediately.
2. Always wear eye protection during installation. Avoid spills, if one occurs, clean up and dispose of towels properly.
3. Never work on a hot engine.
4. Fuel pump booster is pre-programmed to Whipple specifications, do not modify.

****NOTICE:** Installation of Whipple Supercharger products signifies that you have read this document and have agreed to the terms stated within.

It's the purchaser's responsibility to follow all installation instruction guidelines and safety procedures supplied with the product as it's received by the purchaser to determine the compatibility of the product with the vehicle or the device the purchaser intends to install the product on.

Whipple Superchargers assumes no responsibility for damages occurring from accident, misuse, abuse, improper installation, improper operation, lack of reasonable care or all previously stated reasons resulting from incompatibility with other manufacturer's products.

There are no warranties expressed or implied for engine failure or damage to the vehicle in any way, loss of use or inconvenience or labor reimbursement. This includes merchantability and fitness.

ILLUSTRATED INSTALLATION GUIDE

It is strongly recommended that you read through this guide before you begin installing the Whipple Supercharger.

⚠ WARNING!! Batteries normally produce explosive gases. Therefore, do not allow flames, sparks or lighted substances to come near the battery. When charging or working near a battery, always shield your face and protect your eyes. Always provide ventilation. Failure to follow these instructions may result in personal injury.

⚠ WARNING!! Keep out of the reach of children. Batteries contain sulfuric acid. Avoid contact with skin, eyes or clothing. Also, shield your eyes when working near the battery to protect against possible splashing of the acid solution. In case of acid contact with the skin or eyes, flush immediately with water for a minimum of 15 minutes and get prompt medical attention. If acid is swallowed, call a physician immediately. Failure to follow these instructions may result in personal injury.

1. With a 10mm wrench disconnect the (-) negative battery cable. Make sure the cable is far enough away from the battery that it does not accidentally touch the battery and make connection during the installation.



- Remove the 1/8" NPT plug from the back of the supercharger. Install the supplied 1/8" NPT to 1/8" barb fitting, using light amount of pipe sealant on threads. Install the supplied 1/8" ID rubber line to the 1/8" OD barb fitting located on the back of the lower intake manifold. Temporarily route this line down, behind the engine on the passenger side. This will be finished later during the fuel pump booster installation. If you are not using the supplied fuel pump booster, this line will not be used and the 1/8" barbed fitting needs to be removed and replaced with a 1/8" plug, with light amount of pipe sealant.

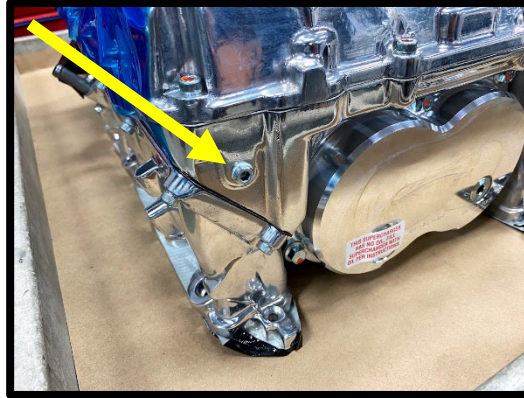

- Familiarize yourself with the supplied MSD Fuel Pump Booster and the supplied wiring. **2018 and up 5.7L applications will mount the booster in the trunk area.**

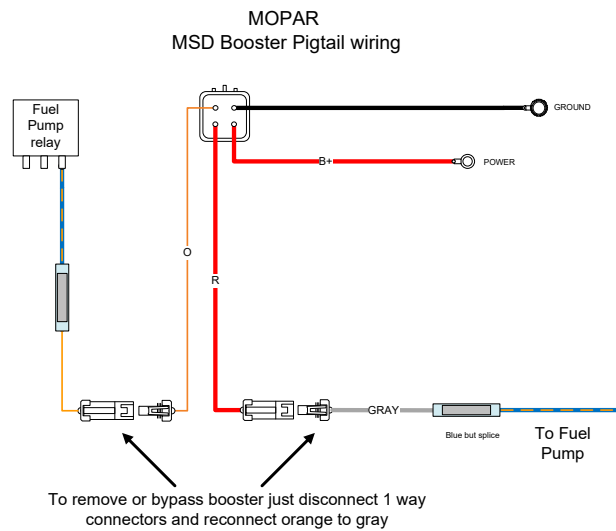

- Using the supplied Velcro, install the MSD fuel pump booster to the back of the battery as shown.



5. Disconnect the B+ cable from the trunk mounted relay box. Release the trunk mounted fuse and relay box from mounting clips and turn over.

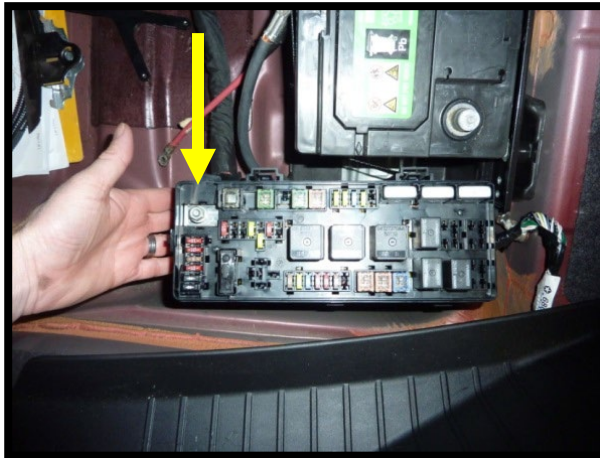

6. Remove the bottom of the trunk mounted fuse/relay box by pulling back on the tabs.

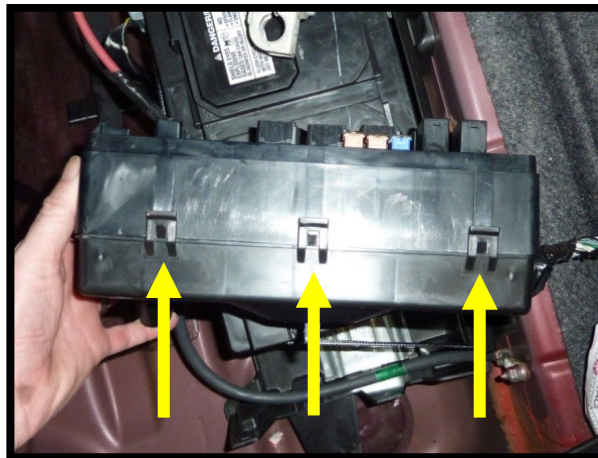

7. Find the factory blue/orange fuel pump power wire and cut this wire (leave at least 3" of wire from relay to ease of work).

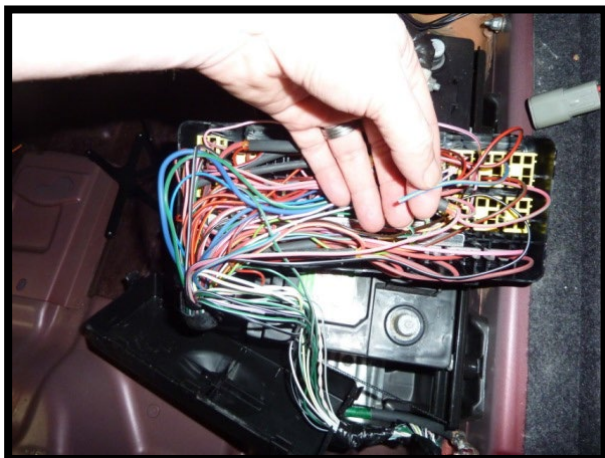
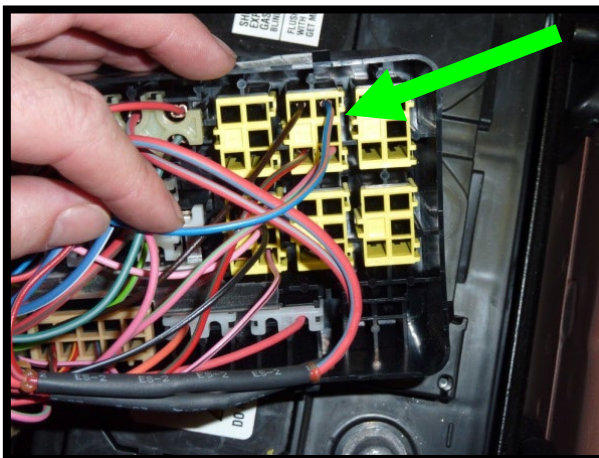

8. Splice in pigtails as shown in MSD Booster diagram.

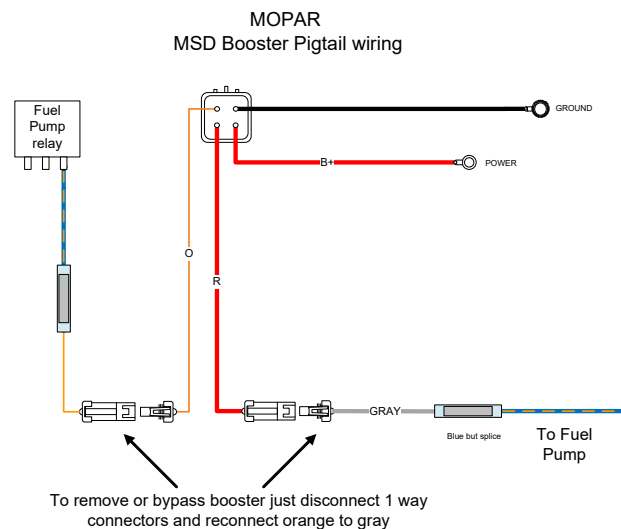
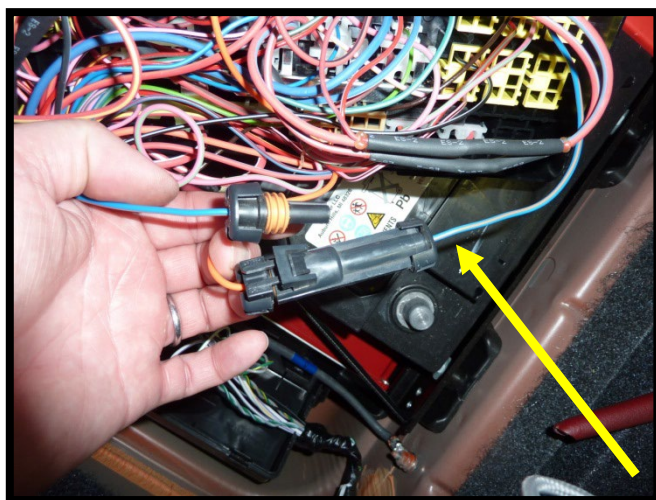

9. Reconnect B+ to relay box stack MSD B+ on top and bolt down.



10. Remove the factory chassis ground and stack the MSD ground to this eyelet and retighten.

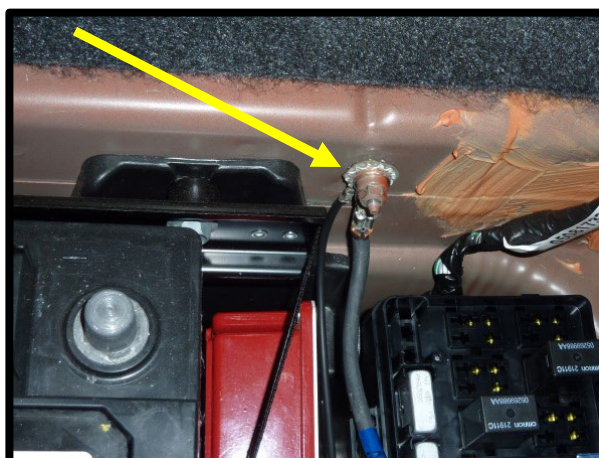

11. Route the supplied 1/8" ID rubber hose that you previously installed on the back of the lower intake manifold, down the passenger side of the chassis (**STAY AWAY FROM THE EXHAUST**). Route along factory lines, securing with zip-ties.

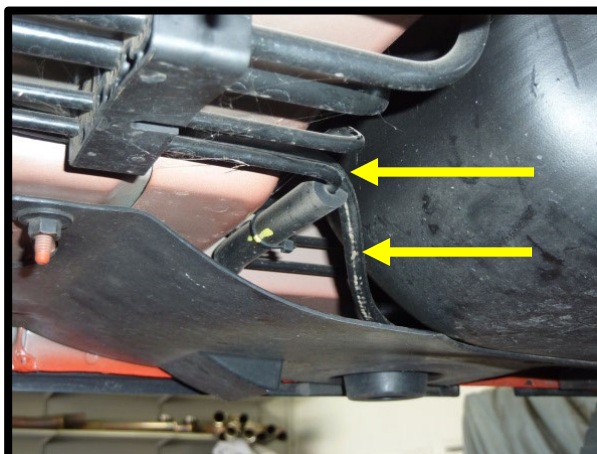
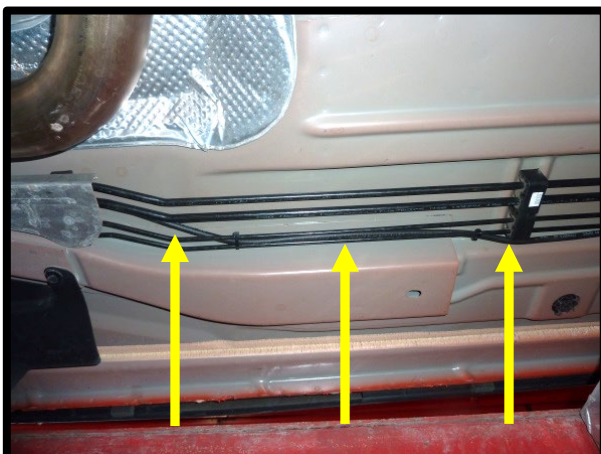
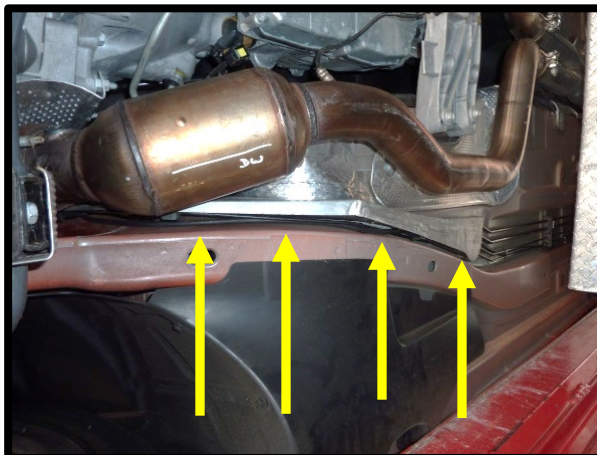
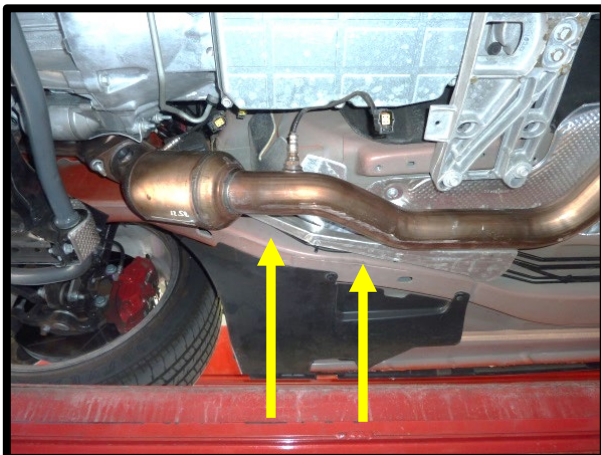

- Using a 5/8" drill bit, drill a small hole for the 1/8" ID fuel pump booster reference line. Install the supplied rubber grommet to the drilled hole. Route the 1/8" ID rubber boost reference line through the rubber grommet.

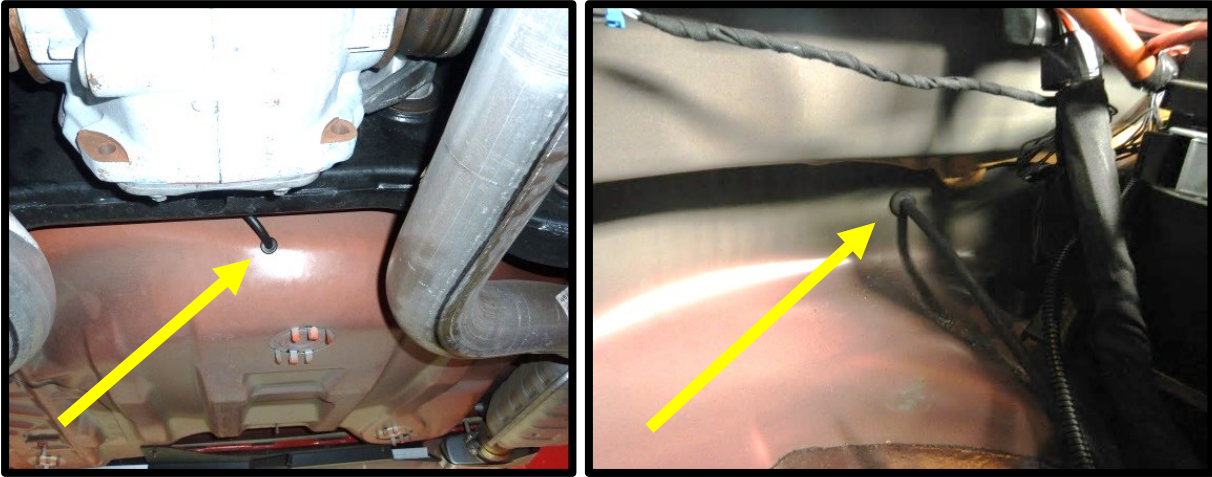

- Using the supplied Velcro, install the MSD fuel pump booster to the back of the battery as shown.

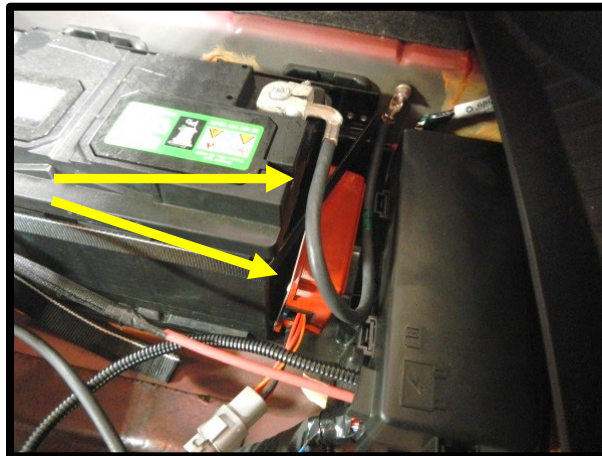

- Connect the routed 1/8" ID boost reference line to the fuel pump booster barbed 1/8" OD fitting. Secure hose to fitting with a zip-tie.
- The MSD booster is pre-programmed and ready to run.
- In the event of a failure, the MSD booster can be bypassed using the pigtailed.