



WHIPPLE *SUPERCHARGER* INSTALLATION MANUAL

2015-2017 FORD F150 5.0L V8



WHIPPLE SUPERCHARGERS

3292 NORTH WEBER AVE

FRESNO, CA 93722

TEL 559.442.1261

FAX 559.442.4153

WWW.WHIPPLESUPERCHARGERS.COM

PREMIUM FUEL ONLY (91 OCTANE OR BETTER ALWAYS) RON+MON/2

CALIFORNIA AIR RESOURCE BOARD EXECUTIVE ORDER D231-63

**COMPETITION BASED PRODUCT MAY BE USED SOLELY ON VEHICLES USED IN SANCTIONED
COMPETITION WHICH MAY NEVER BE USED UPON A PUBLIC ROAD OR HIGHWAY**

INTRODUCTION

Before beginning installation, please read this manual and important notes:

Before beginning installation, please read this manual and important notes:

- Please read the installation manual and verify that all items are present. If you are missing hardware or have any questions, please contact your dealer or Whipple Superchargers.
- Premium fuel (US 91 octane) is required to prevent spark-knock/detonation under certain operating conditions. Other countries must meet US 91 octane standards, RON+MON/2. **If fuel of less than 91-octane is present in the vehicle fuel tank, the tank must be completely drained and refilled with 91 or higher octane to 1/8th of a tank. The fuel system is returnless, therefore, initial fuel in the system will be low octane. Drain all fuel!**
- Operating your engine without the Whipple PCM recalibration can result in engine damage or failure and will void your warranty.
- **NEVER MANUALLY MOVE THE BYPASS ACTUATOR, YOU CAN RUPTURE THE INTERNAL DIAPHRAM.**
- Supply your VIN number (along with gear ratio, transmission type, throttle body type and any changes to vehicle) to Whipple ahead of time so your unique PCM calibration can be built prior to the PCM being shipped or calibration emailed to minimize any down time.
- Instructions reference **LH** (Left Hand) and **RH** (Right Hand) side of vehicle. This is if your sitting in drivers seat facing forward.

COMPETITION BASED PRODUCT MAY BE USED SOLELY ON VEHICLES USED IN SANCTIONED COMPETITION WHICH MAY NEVER BE USED UPON A PUBLIC ROAD OR HIGHWAY, UNLESS PERMITTED BY SPECIFIC REGULATORY EXEMPTION (VISIT THE "EMISSIONS" PAGE AT [HTTP://WWW.SEMASAN.COM/EMISSIONS](http://www.semasan.com/emissions) FOR STATE BY STATE DETAILS.

COMPETITION BASED PRODUCT IS LEGAL IN CALIFORNIA ONLY FOR RACING VEHICLES WHICH MAY NEVER BE USED, OR REGISTERED OR LICENSED FOR USE, UPON A HIGHWAY.

IT IS THE RESPONSIBILITY OF THE INSTALLER AND/OR USER OF THIS PRODUCT TO ENSURE THAT IT IS USED IN COMPLIANCE WITH ALL APPLICABLE LAWS AND REGULATIONS.

RECOMMENDED TOOLS AND SUPPLIES

The following items are not included in this supercharger kit and it is strongly recommended that they're used for ease of installation or maximum performance:

Tools

¼", 3/8" and ½" torque wrenches. Safety glasses, metric wrench set, electric or air drill, 1 ½" hole-saw, ¼", 3/8", ½" assorted metric socket set, 3/8" assorted metric allen socket set, 5mm ball allen socket, 3/8" assorted torx socket set, 8mm hex allen wrench, ½" breaker bar, flat head and drain pan (for coolant). Heat gun or small torch for heat shrinking. Electric tape. Trim pad tool (for pushpin removal). You will need an assortment of 4", 8" and 12" zip ties. Clean shop towels.

Sealants/Liquids

Thread sealant such as pipe Teflon must be used on all pipe threads. Ant-seize for bolt and spark plug threads (use only when stated, otherwise the torque value must be reduced). you will need some cleaner/degreaser such as carb cleaner. Assembly lubricant (white lithium grease or petroleum jelly).

You'll be required to fill your intercooler system with approx. 2 gallons of distilled water and Ford Factory specification engine coolant. This is not supplied in the system, you can find the coolant at any local auto parts store. NEVER USE TAP WATER, as it can corrode and create poor performance.

PRE-INSTALLATION CHECKLIST

Before installing your Whipple Supercharger Kit, complete the following checklist.

1. Verify Condition of Vehicle: Before the supercharger kit is installed, ensure the engine runs smoothly and that the factory malfunction indicator light (MIL) is off. Only install the supercharger kit if the engine runs smoothly *and* the MIL is off.
2. **!! CAUTION !!** This product is intended for use only on **STOCK, UNMODIFIED, WELL-MAINTAINED** engines. Installation on a worn-out or modified engine is not recommended without factory computer and fuel system modifications. Custom engine configurations could require custom tuning and other supporting modifications.
3. Verify Fuel System: Supercharger systems should only be installed on vehicles that have new or clean fuel filters.
4. Assess Cleanliness of Installation Area: Make sure your work area and the under hood area are free from debris. This supercharger is a high-quality, close-tolerance compressor and must not be subjected to contamination by dirt or any type of foreign material. If necessary, vacuum around engine to remove any foreign material.
5. **!! CAUTION !!** **DO NOT** remove the protective seal on the supercharger prior to installation. Foreign material entering the supercharger will automatically void all warranties.
6. Identify Supercharger Kit Components: Before beginning installation, identify all the components of your Whipple Supercharger Kit and ensure all items are present and undamaged.
7. **!! CAUTION !!** Do not attempt to start the engine before adding the supplied Supercharger Oil to the supercharger!

SAFETY PRECAUTIONS



CAREFULLY READ THE IMPORTANT SAFETY PRECAUTIONS AND WARNINGS BEFORE PROCEEDING WITH THE INSTALLATION!

Appropriate disassembly, assembly methods and procedures are essential to ensure the personal safety of the individual performing the kit installation. Improper installation due to the failure to correctly follow these instructions could cause personally injury or death. Read each step of the installation manual carefully before starting the installation.

- Always wear safety glasses for eye protection.
- Place the ignition switch in the off position.
- Always apply the parking brake when working on vehicle.
- Block the front and rear tire surfaces to prevent unexpected vehicle movement.
- Operate the engine only in well-ventilated areas to avoid exposure to carbon monoxide.
- Do not smoke or use flammable items near or around fuel system.
- Use chemicals and cleaners only in well-ventilated areas.
- Batteries can produce explosive hydrogen gas which can cause personal injury. Do not allow flames, sparks or flammable sources to come near the battery.
- Keep hands and any other objects away from the radiator fan blades.
- Keep yourself and your clothing away from moving parts when the engine is running.
- Do not wear loose clothing or jewelry that can be caught in rotating or moving parts.

GLOSSARY OF TERMS

ABBREVIATION	DESCRIPTION
DTC	Diagnostic Trouble Code
ECT	Engine Coolant Temperature
EGR	Exhaust Gas Recirculation
ETC	Electronic Throttle Control
EVAP	Evaporative emissions system
FHSCS	Flat Head Socket Cap Screw
IAT	Inlet Air Temperature
IC	Intercooler
ID	Internal Diameter
LB-IN	Pound-force inch
LB-FT	Pound-force foot
LTR	Low temp radiator
MAF	Mass Air Flow
MAP	Manifold Absolute Pressure
MY	Model Year
OBD	On Board Diagnostics
OD	Outside Diameter
PCV	Positive Crankcase Ventilation
PSI	Pound per Square Inch
SC	Supercharger
SHCS	Socket Head Cap Screw
TPS	Throttle Pressure Sensor
TRQ	Torque



****NOTICE:** Installation of Whipple Supercharger products signifies that you have read this document and have agreed to the terms stated within.

It's the purchaser's responsibility to follow all installation instruction guidelines and safety procedures supplied with the product as it's received by the purchaser to determine the compatibility of the product with the vehicle or the device the purchaser intends to install the product on.

Whipple Superchargers assumes no responsibility for damages occurring from accident, misuse, abuse, improper installation, improper operation, lack of reasonable care or all previously stated reasons resulting from incompatibility with other manufacturer's products.

There are no warranties expressed or implied for engine failure or damage to the vehicle in any way, loss of use or inconvenience or labor reimbursement. This includes merchantability and fitness.

The information contained in this publication was accurate and in effect at the time the publication was approved for printing and is subject to change without notice or liability. Whipple Superchargers reserves the right to revise the information presented herein or to discontinue the production of parts described at any time.

SUPERCHARGER INSTALLATION INSTRUCTIONS

It is strongly recommended that you read through this guide before you begin installing the Whipple Supercharger.

1. Follow the supplied flash tool instruction manual for the Whipple Superchargers calibration process.
2. Using an air hose, blow off any loose dirt or debris from engine compartment. If really dirty, then steam clean the engine compartment before proceeding to the next step.
3. Release the fuel system pressure.

WARNING : Fuel in the system remains under high pressure even when the engine is not running. Before working on or disconnecting any of the fuel lines or fuel system components, the fuel system pressure must be relieved. Failure to do so can result in personal injury.

WARNING : Do not smoke or carry lighted tobacco or open flame of any type when working on or near any fuel-related components. Highly flammable mixtures are always present and can be ignited, resulting in personal injury.

A: Disconnect the Fuel Pump Control Module electrical connector. This is located under the bed, near the spare tire.

B: Start the engine and allow it to idle until it stalls.

C: After the engine stalls, crank the engine for approximately 10 seconds to make sure the fuel injector supply manifold pressure had been released.

D: Turn the ignition switch to the OFF position.

E: Reconnect the fuel pump driver module.

4. Locate the battery on the passenger side of vehicle. With an 8mm wrench disconnect the (-) negative battery cable. Make sure the cable is far enough away from the battery that it does not accidentally touch the battery and make connection during the installation.
5. With a cool engine drain the coolant into a clean drain pan for reuse later. Remove the radiator cap to vent the system. (Be careful not to remove the radiator cap if the engine is still hot). The drain petcock is located on the bottom side of radiator. Loosen spigot and let it drain into pan. Add a 3/8" ID hose to the end of the petcock for cleaner procedure.
6. Lift the front of the vehicle using the Ford recommended lifting points and place on to safety stands.

7. Remove the factory plastic radiator shroud by pulling the center of the (9) push pins and then out. Use a flat head screw driver to pry the center head up. This will all be reused.

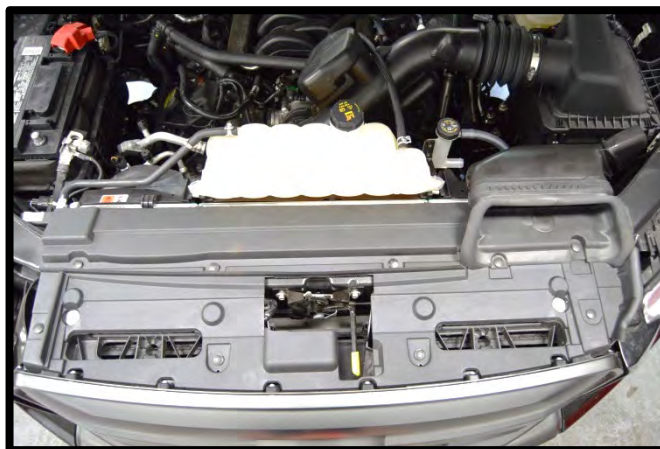

8. Remove the factory plastic quick connect fitting from inlet coming from brake booster.



9. Remove the driver side and passenger side valve cover vent line quick connect fittings from the inlet tube by squeezing the connector and pulling away. Remove from valve cover by squeezing the connector and pulling away.

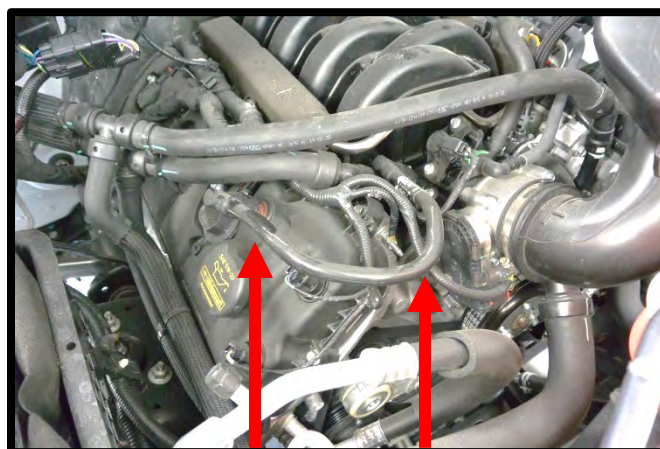

10. Unclip the airbox lid by flipping the (2) tabs to release. Using a 5/16" nut driver, loosen the factory hose clamp securing the air inlet tube to the air box lid and throttle body. Remove airbox lid from engine. Remove air filter from airbox.

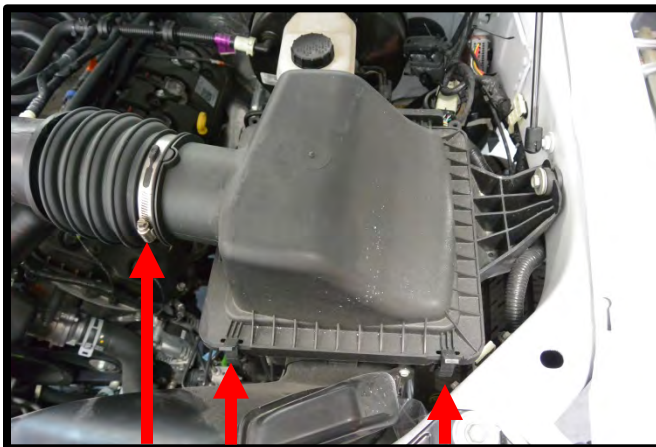

11. Using a 13mm socket, remove the (1) factory fastener securing airbox to the fender (bolt and grommet will be reused later).

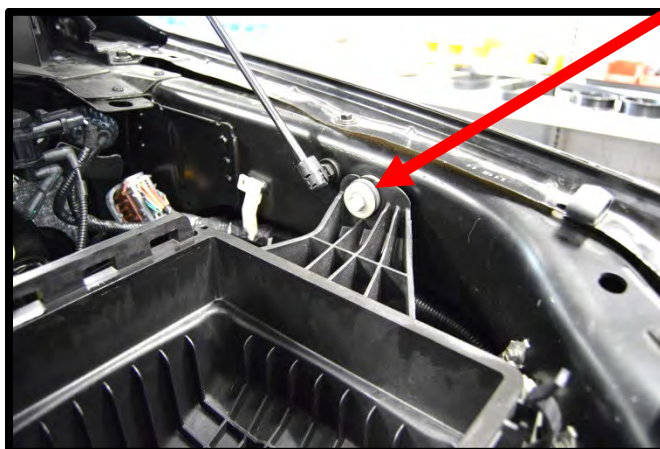

12. Using a pair of pinch clamps, remove the vent line from the coolant overflow tank to the water neck.

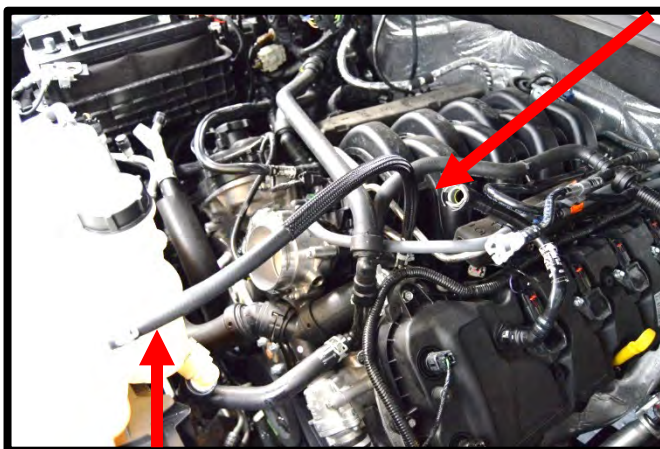

13. Disconnect the EVAP solenoid connector by squeezing locking tab and pulling away.

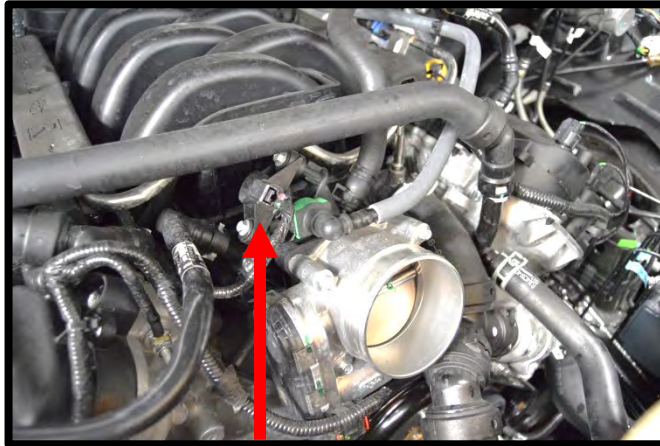

14. Remove the EVAP vent line quick connector from the EVAP solenoid by pushing the (2) locking tabs away and squeezing the tab, then pull away. Pull this line away from engine (goes down to driver side lower firewall area).

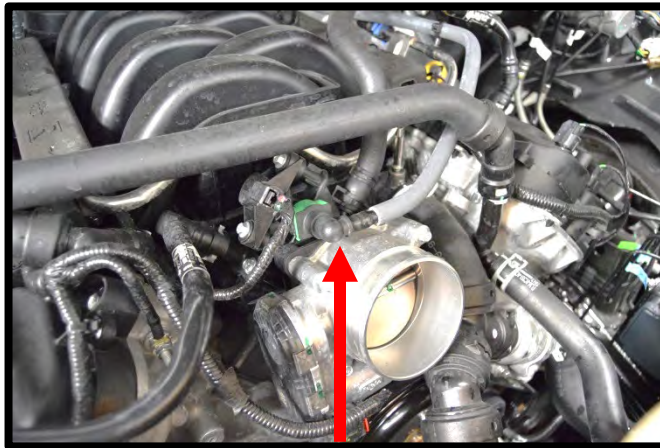

15. Remove the manifold vent hose next to the EVAP, use a pinch clamp tool to remove pinch clamp and hose.

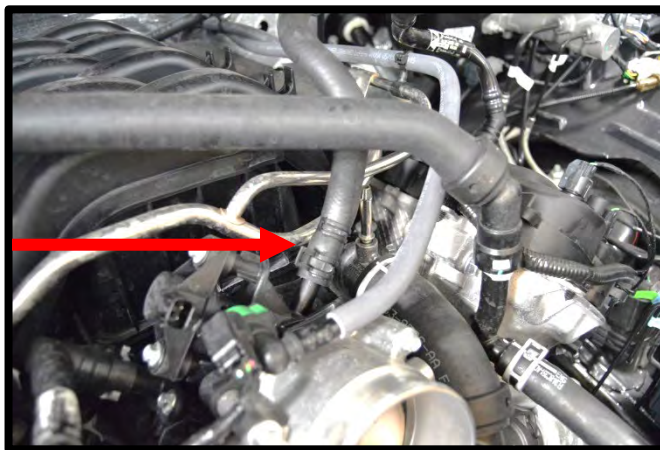

16. Carefully cut the electric tape securing the ETC wires to the throttle body. Disconnect the electronic throttle electrical connector by pushing up on the safety lock and then squeezing the connector and pulling away.

17. Remove the heater hose from passenger side of block by pulling locking tab back and pulling away. Push to the back of the engine for later use.



18. Remove the quick connect fitting on the heater tube, drivers side. Push hose to the back of the engine for later use.

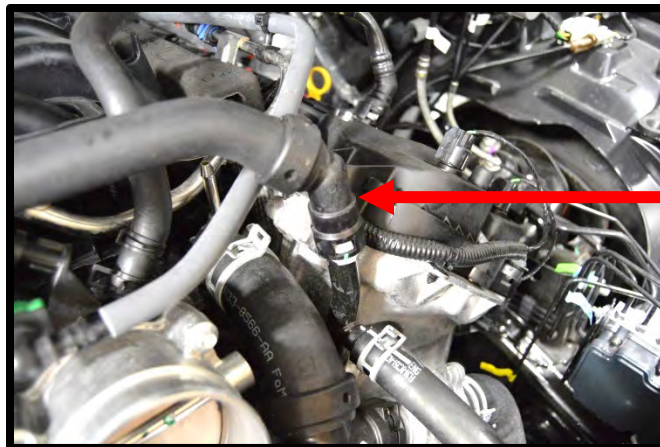

19. Remove the brake booster vacuum line from check valve and IMRC vacuum lines from brake booster line (separate where the arrow points). The check valve closest to the brake booster connector will be utilized.

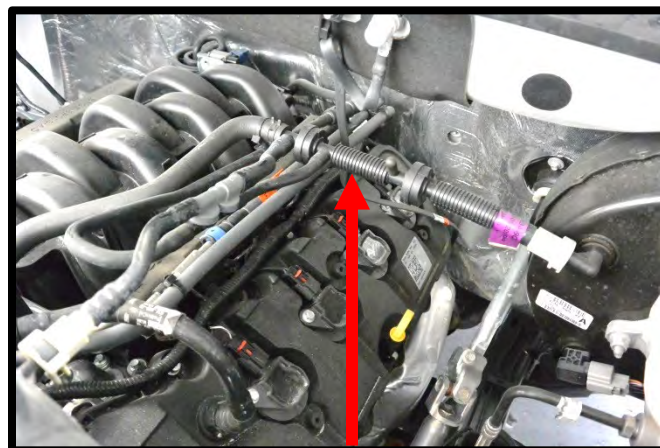

20. Carefully remove the factory fuel line by releasing the blue safety lock, then squeezing the connector and pulling back. The fuel system may still have pressure, use protective eyewear and multiple rags to catch any possible fuel leak.



21. Remove the coolant to heater tube overflow hose using a pinch clamp tool. Pull away from heater tube.

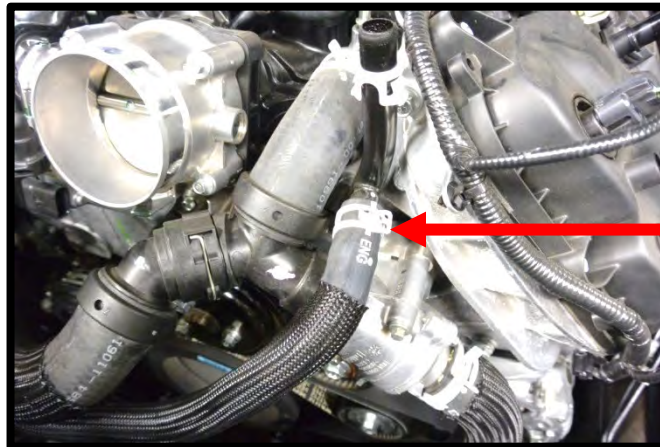

22. Remove the water neck hose using a pinch clamp tool. Pull away from water neck.

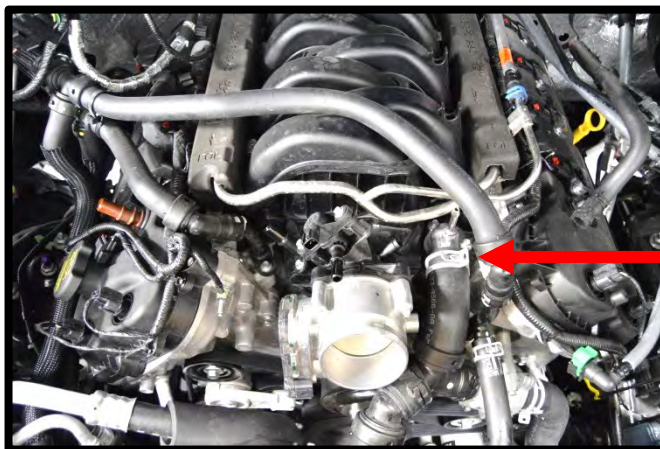

23. Loosen the 4 bolts holding the fuel rails down, these go through to the cylinder head (10mm socket). Fuel rail does not need to be removed.

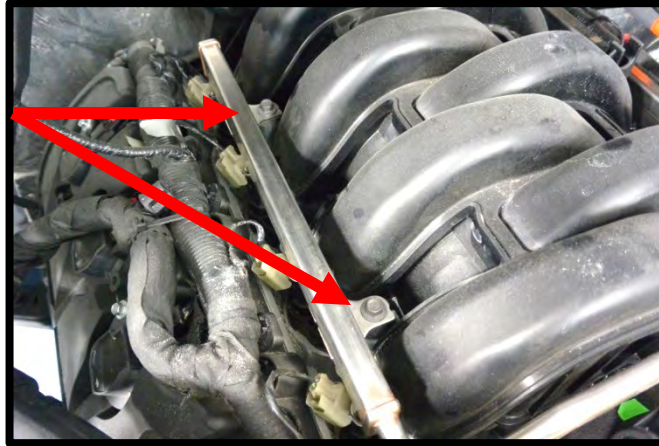

24. Loosen the (8) manifold to cylinder head bolts using an 8mm socket.
25. Remove fuel rail foam covers.
26. Disconnect all fuel injector connectors by using a flat head screw driver on one side of the clip. Pry to one side and clip will slide off.
27. Remove the intake manifold from the engine. Pull up from the front then remove the (2) wire harness push pin supports from the back of the intake manifold and disconnect the (2) IMRC solenoid connectors and (2) IMRC position sensor connectors by pushing on the locking tab and pulling away IMRC solenoid. Remove from the driver side, rear of intake manifold, 4-way MAP sensor connector by pushing on the locking tab and pulling away.
28. Clean the intake manifold to cylinder head surface using carb cleaner or acetone. Install tape over the exposed ports until manifold installation.
29. Remove the **LH** side heater tube from engine by removing the bolt using an 8mm socket.

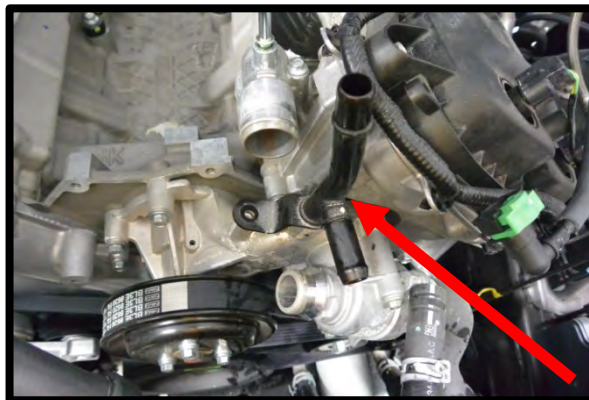

30. Install the supplied MAP sensor pigtail to the factory MAP sensor 4-way connector. Press together until it clicks and locks in place. Route the other end to the driver side, back of cylinder head for later installation to new MAP sensor.

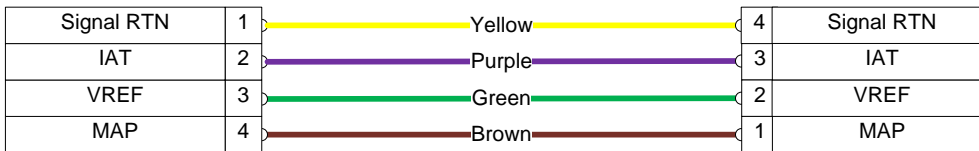

Male plugs into
FACTORY HARNESS SIDE

MAP Connector to plug
into sensor shown

31. Using a gapping tool, gap supplied spark plugs to .028" (NGK LTR7IX or Denso ITV22). **NEVER** adjust with feeler gauge or similar in plug while adjusting, this can damage the fine wire. Install the gapped plugs. Apply light amount of anti-seize to threads. Torque spark plugs to 124 lbs-in. Reinstall the coils on plugs and torque bolts to 97 lbs-in.



32. Disconnect the driver side heater tube quick connect fitting by squeezing and lifting away. Remove the heater tube overflow hose using a pinch clamp tool. Using an 8mm socket on the 1 factory bolt, remove the heater tube. Install the supplied oring to the shorter heater tube and install to factory location, secure with stock bolt, torque to 89 lbs-in. Reconnect both factory hoses, secure lower hose with stock clamp.

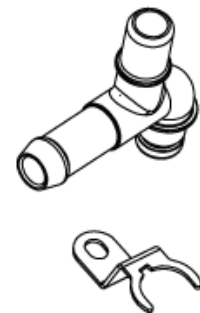
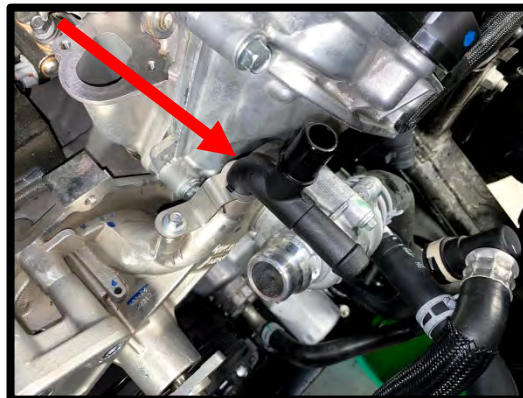

33. Pull the fuel feed and EVAP lines away from mounting bracket at the back of the driver side head.



34. Cut the factory EVAP hose just below the 90deg bend (.125" below). NOTE: Make sure this cut is straight.

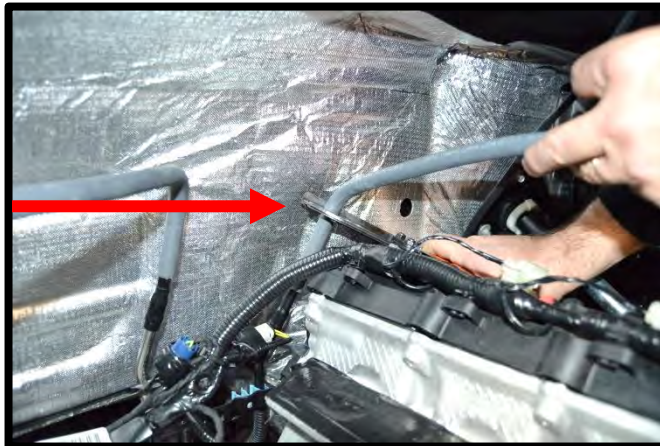

35. Using the supplied brackets (IC reservoir mounting brackets), (2) 8mm x 90mm SHCS (2) and #4 hose clamps, install the plastic coupler into the factory EVAP hose you just cut. Apply grease to plastic coupler to aid in installation. Use the hose clamps to hold the hose in place at the bottom of the hose. Slowly tighten the 8mm bolts until the coupler is fully installed.

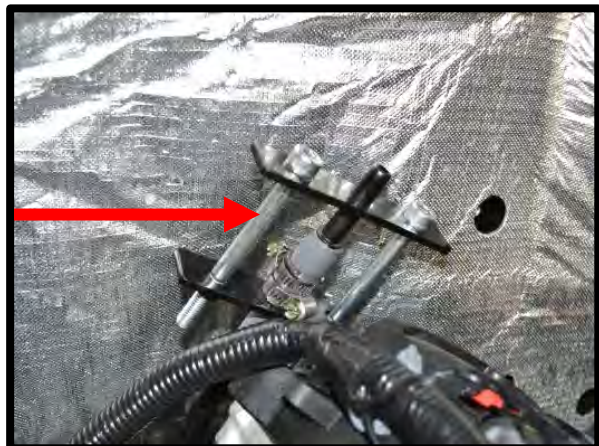

36. Reinstall the factory fuel feed line into the factory support bracket on the driver side cylinder head.

37. Loosen the (3) bolts securing the water pump pulley using a 10mm socket (while belt is on). Remove the belt from the engine by using a 15mm socket on a ½" breaker bar and rotating the spring-loaded tensioner in a clockwise direction. Remove water pump pulley using a 10mm socket (this will be reused).

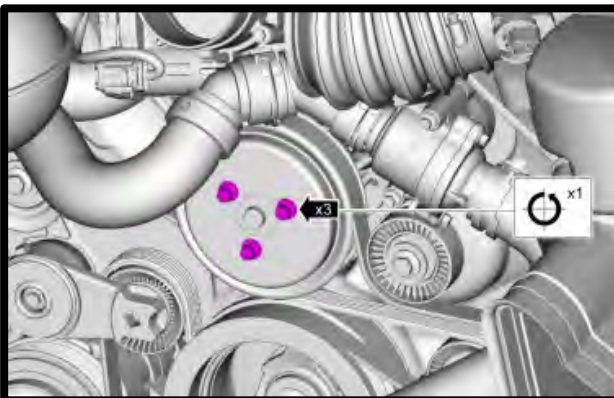
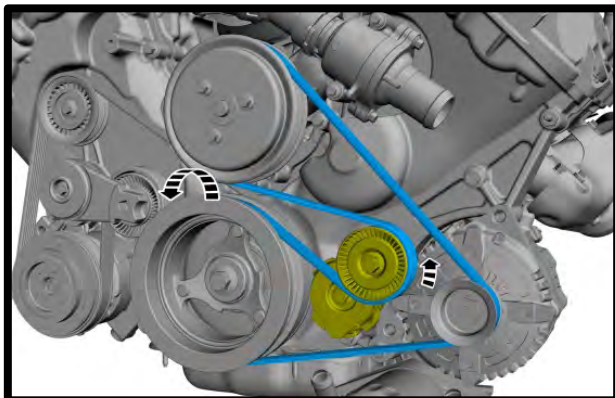

38. Using a 10mm socket, remove the (3) factory fasteners from the timing chain to head cover and (1) from water pump (for new idler plate).

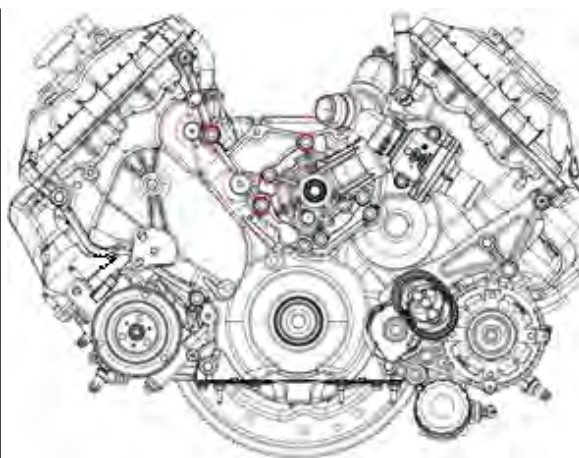
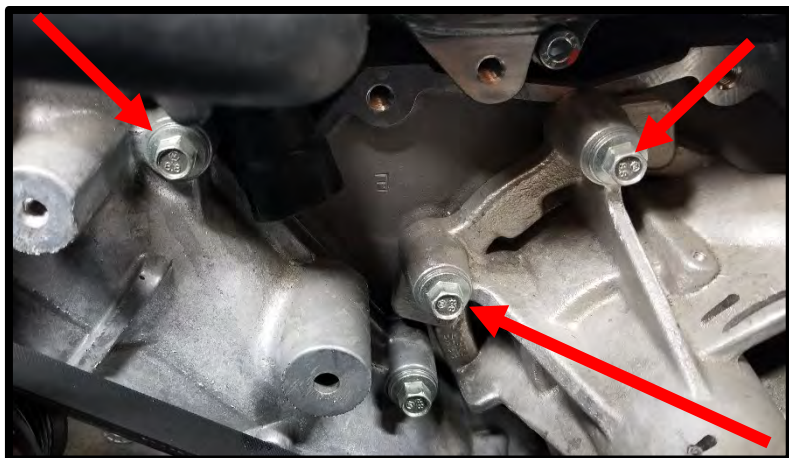

39. Use the supplied (3) 8mm x 90mm SHCS to secure the idler plate to the engine. Using a 6mm allen, torque to 22 lbs-ft.

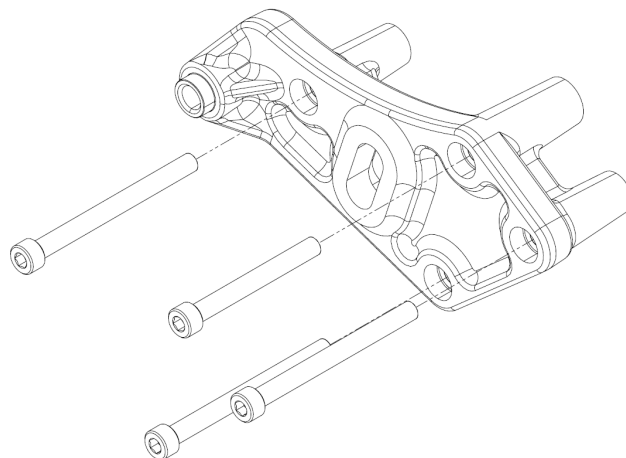
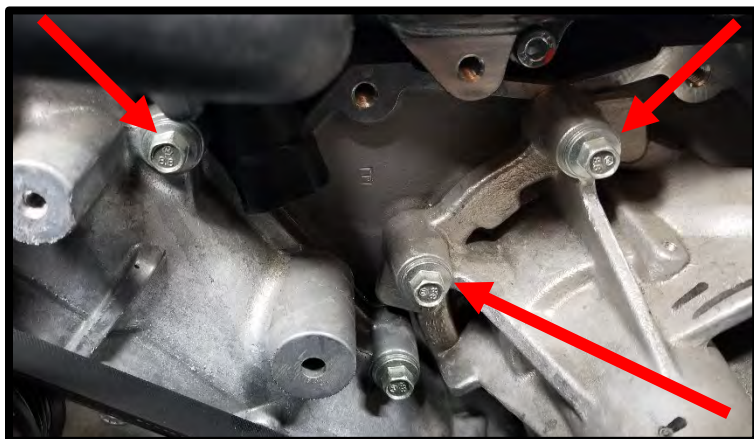

40. Install the supplied (2) -6 ORB plugs to RH (passenger side) fuel rail. Plug the side port and front port. Apply light amount of grease to oring for ease of installation.



41. Install the supplied (2) #2-906 orings to the (2) inlet/outlet fittings. Install these (2) fittings into rear side of fuel rails. Apply light amount of grease to oring for ease of installation. Using a 3/4" wrench (or 3/4" deep socket) on both the front and rear fittings, tighten both.



42. Install the (1) supplied 6AN 180deg swivel fittings to front port on LH rail. Using a 3/4" wrench, secure fittings to fuel rails.



43. Install the fuel injectors to the fuel rail, apply generous amount of grease to oring for easy installation. Install the supplied fuel injector position lock bracket to clock the supplied fuel injectors into proper position. While installing the lock bracket, secure the fuel injector so it does not add pressure to the injector body. **Note:** This is for dual spray pattern injectors only that must be at the correct angle. **WARNING: Failure to clock the injector correctly can cause severe running issues.**

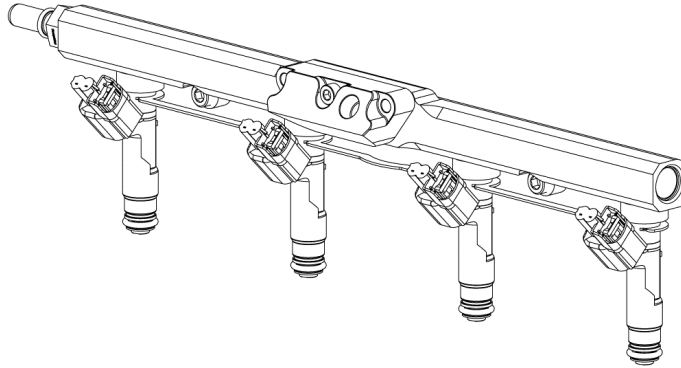

44. Install the supplied (1 per injector port) .515" injector shims to be installed to the injector port of the SC housing, to hold the injector up to its proper position. Install the fuel injectors to the fuel rail, apply generous amount of grease to oring for easy installation.



45. Install the (3) supplied 6AN viton orings (#906) to the (1) 6 ORB to 9.89mm and the (2) 6 ORB to 15.82mm quick connect fittings supplied. Bank 2 side, install (1) 15.82mm fitting to the lower port using a 7/8" deep socket and the 9.89mm fitting in the top port using a 11/16" deep socket. Bank 1 side, install (1) 15.82mm fitting to the lower port using a 7/8" deep socket. Install the supplied 6AN plug with oring to lower port, bank 1 using a 6mm allen.

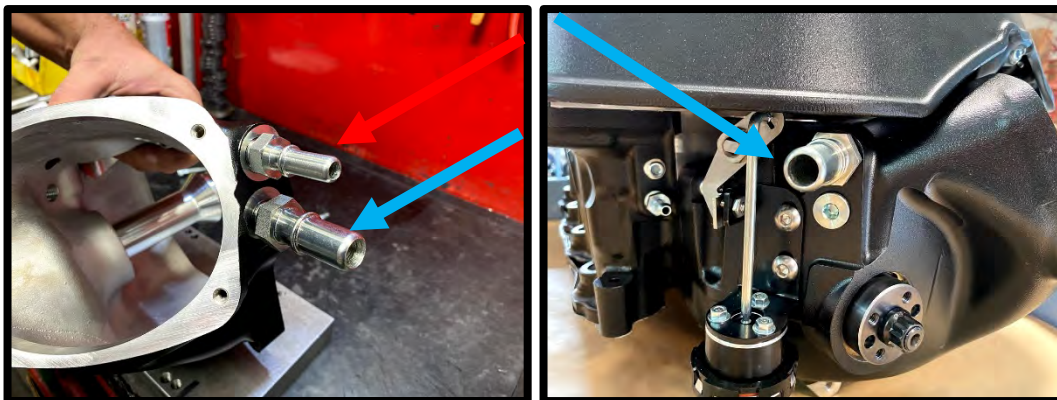

46. Using the supplied 5/16" OD silicone tube, install the (1) 80 1/2" cord. Start as shown with green arrow, go in a clockwise motion, to the front, then around the perimeter. End at yellow arrow position. Bunch it up so it has no gap at the end as any gap will be an air leak of un-intercooled air. Install the (1) 6.5" cord in the front section shown with the blue arrow.

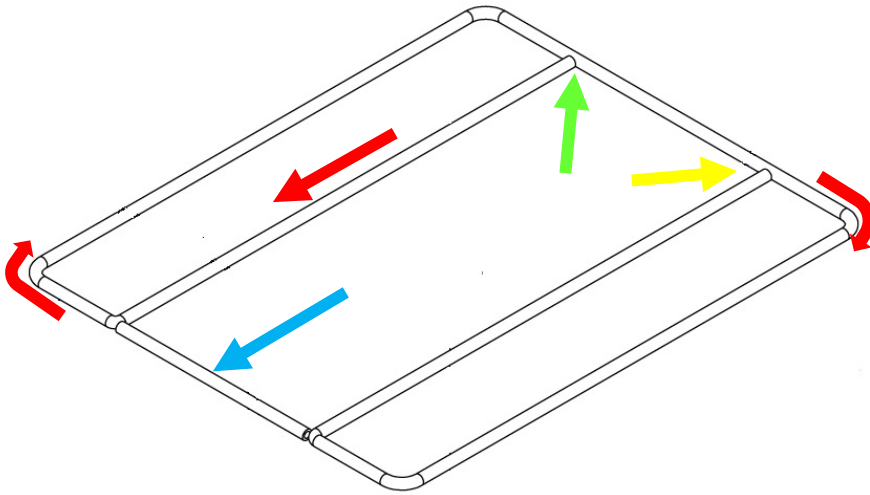

47. Install the supplied pre-formed 65.3" x .103" oring to the top sealing surface of the SC housing. Apply generous amount of grease to help ease the oring into place. **TIP:** To install oring into dove-tail groove, press vertically, vs sliding finger along.

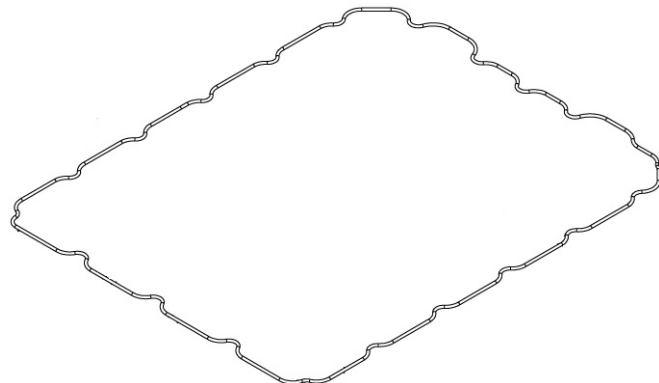

48. Install the supplied 3-bar TMAP sensor to the front of the intake manifold using the supplied (1) 6mm x 20mm SHCS with the (1) 6mm AN washer with light amount of **Blue Loctite #243** to the threads. Apply generous amount of grease to the rubber oring for easy installation. Torque to 65 in-lb.

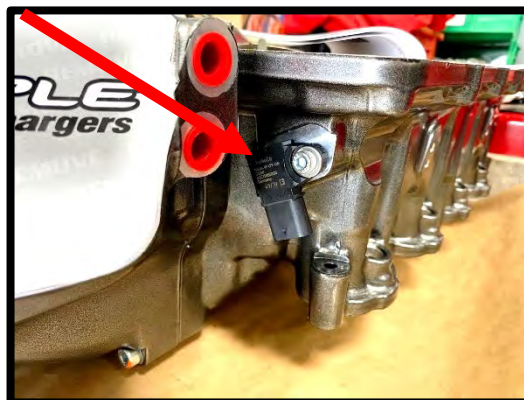

49. Install the supplied TMAP pigtail to the 3-Bar TMAP supplied, wrap up to SC inlet as this will get connected to stock harness later.

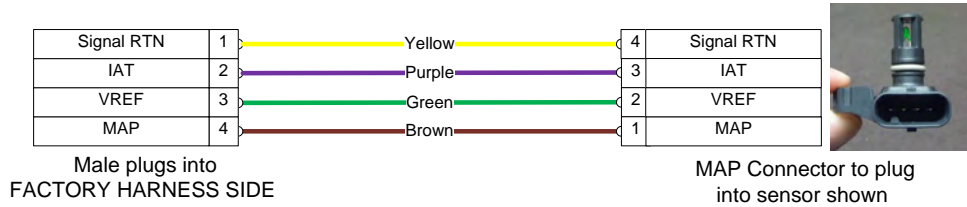

50. Install the supplied (8) manifold orings into the Whipple intake manifold.



51. Make sure the supercharger is on a flat surface. Remove the oil fill plug using an 8mm allen socket.
- Fill the compressor to the **BOTTOM** of the fill plug (**4.0 FL/OZ**). Rock compressor back and forth. Then spin the compressor/rotors by the pulley so the oil fills the bearings. **NEVER OVER FILL THE SUPERCHARGER!**
 - Apply light amount of grease to oil fill plug oring, reinstall. Torque to 140 lbs-in.

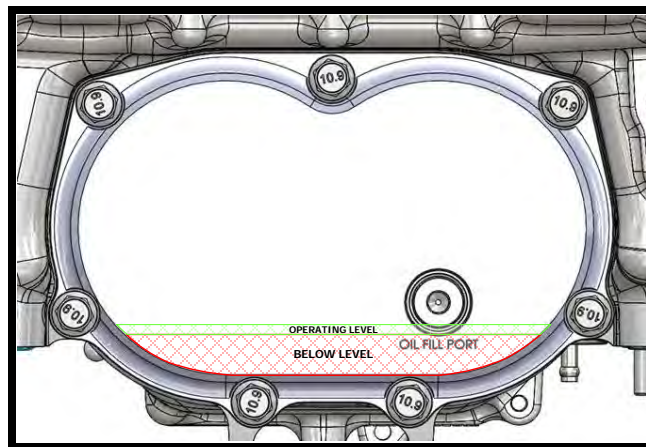

52. Remove the tape you previously installed on the exposed ports on cylinder head. Clean surface with carb cleaner or acetone.

53. Install the supercharger housing (without lid) to the engine. Use the supplied (4) 6mm x 55mm HHFCS on the outer bolt holes. Use the (6) 6mm 80mm HHFCS bolts with the supplied (6) #2-009 orings on the bolt, under the head. Use **Blue Loctite #243** on the threads of each bolt. Leave hand tight for now.



54. Using a 6mm allen socket, secure the (1) 8mm x 70mm SHCS to the front support. Torque to 22 lbs-ft.

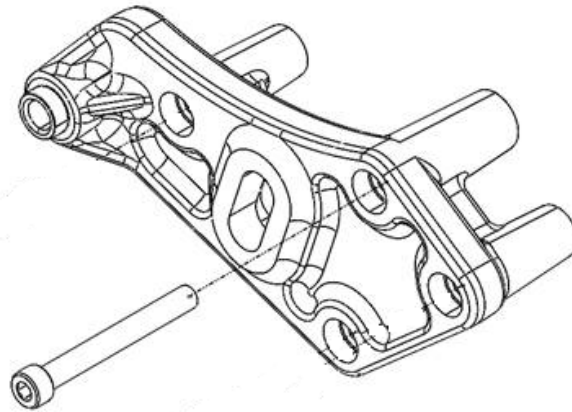

55. Torque the (10) 6mm (10) HHFCS bolts in the following pattern using a 10mm socket. First pass: 88 lbs-in. Second pass: 106 lb-in. **NOTE:** For bolt #10, a 1/4" socket with 4"-6" extension, 10mm wobble is the best possible tool to get into this tight area.

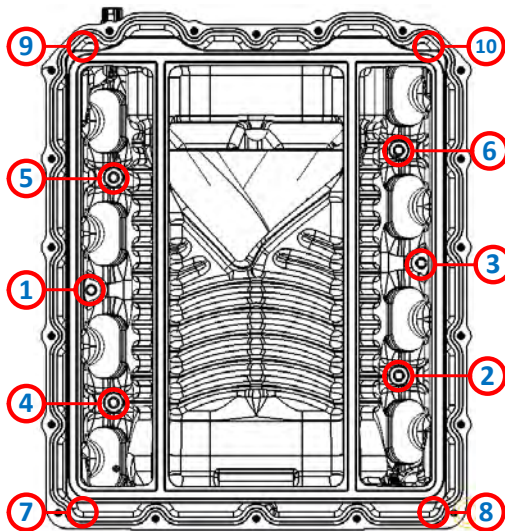

56. Connect the supplied 3-way to 4-way MAP sensor pigtail to the factory driver side IMRC 3-way connector, located at the back of the engine. Route to the driver side front of engine for later installation at airbox.
57. Install the supplied 3/8" fuel cross over line around the back of the supercharger by pressing until they click and lock in place. 90deg side goes to driver side.



58. Connect the TMAP extension to stock TMAP 4-way connector.

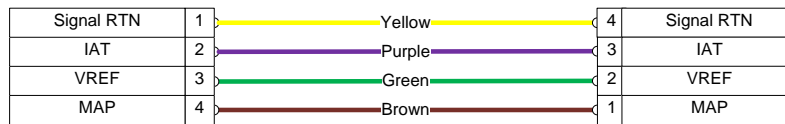

Male plugs into
FACTORY HARNESS SIDE



MAP Connector to plug
into sensor shown

59. Install the supplied electronic throttle pigtail to the factory electrical connector. Route under front idler plate front support for proper safety from belt. Push until it locks in place, then lock the safety lock. Route to **LH** side of vehicle for later connection to throttle body. **TIP:** When pressing together, hold the wires vs connector to ensure the wires do not come loose during connection.

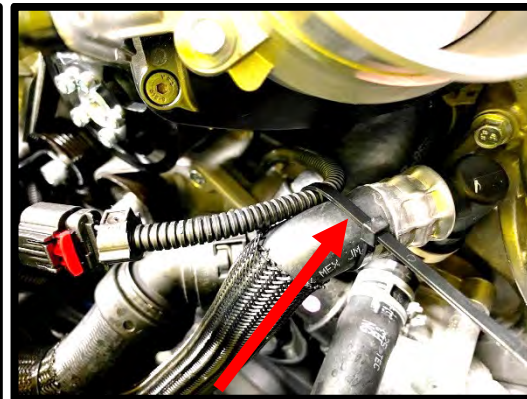
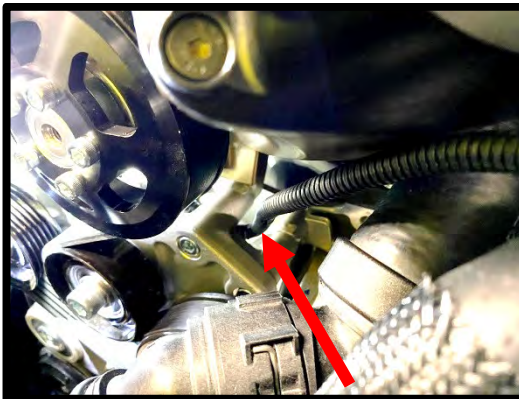

60. Reinstall the water pump pulley using a 10mm socket, torque to 14 lbs-ft.

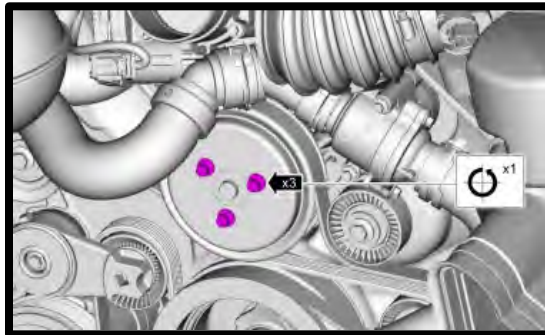

61. Plug the (8) fuel injector electrical connectors to the new fuel injectors until they click and lock in place.
62. Rotate the water neck vent line hose clamp so it's facing forward. Failure to do this will result in possible leak.

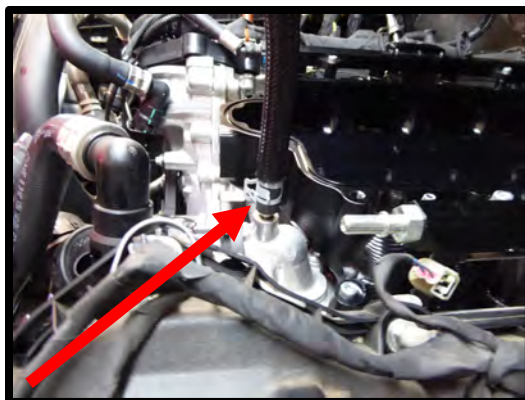

63. Connect the factory heater hose quick connect to factory heater tube (bank 1).



64. Connect factory heater hoses to previously installed plastic water fitting (bank 2).

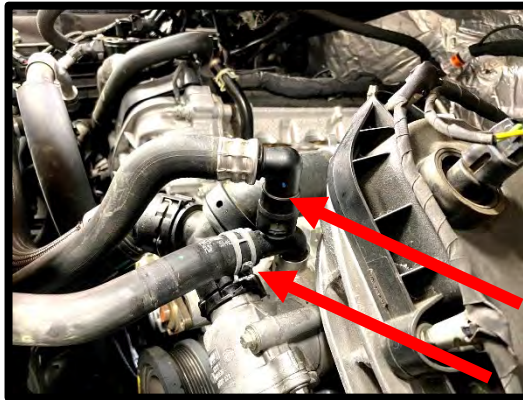

65. Install the EVAP to the supplied billet adapter with electrical connector facing the back of engine. Install the supplied 9.89mm quick connect fitting and 6AN oring to billet adapter. Secure supplied EVAP bracket to the supercharger lid using the supplied (2) 6mm x 10mm HHFCS bolts. Secure EVAP assembly to bracket using the supplied (2) 6mm x 20mm HHFCS bolts. Use the supplied 3/8" ID hose. Cut hose to fit between previously installed EVAP fitting, to EVAP solenoid rear fitting. Install the supplied 90deg fittings to hose and connect hose from factory EVAP line to solenoid rear fitting.

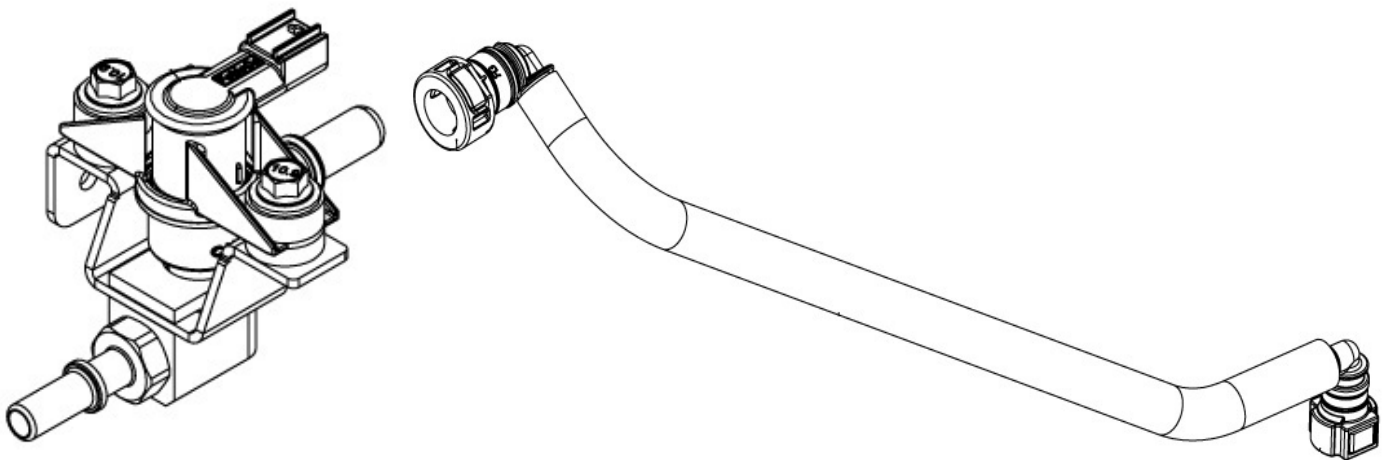

66. Install the (1) #2-230 internal bypass oring to the lid bypass passage. Use generous amount of grease to secure oring in place and help with lid installation.



67. Apply generous amount of grease to the (1) #2-230 Viton bypass oring. Install the supercharger lid to the supercharger housing by carefully placing the bypass down. Secure the SC lid using the (17) 6mm x 30mm HHFCS and (3) 6mm x 70mm HHFCS (*marked green*) using the following pattern. Slide the EECPV bracket under bolts 3 and 5 from image (LH). Torque to 90 lbs-in using an 8mm socket.

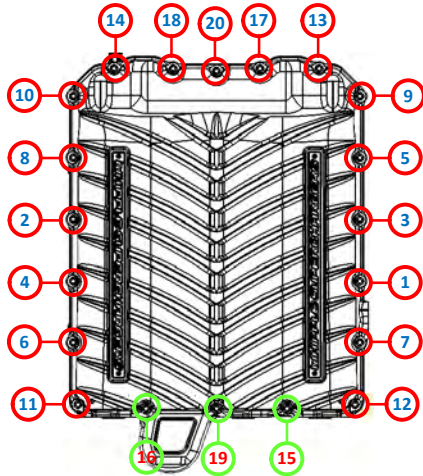

68. Install the supplied (1) smooth idler pulley #36101 using the (1) .390" step spacer along with the "Tee-nut" in the idler plate. The tee-nut needs to be installed from the back of the plate, this allows for belt slack adjustment. Sandwich the idler pulley to the step spacer using the supplied (1) step spacer and (1) ½"-13 x 1 ¾" SHCS. Leave hand tight until the belt installation.

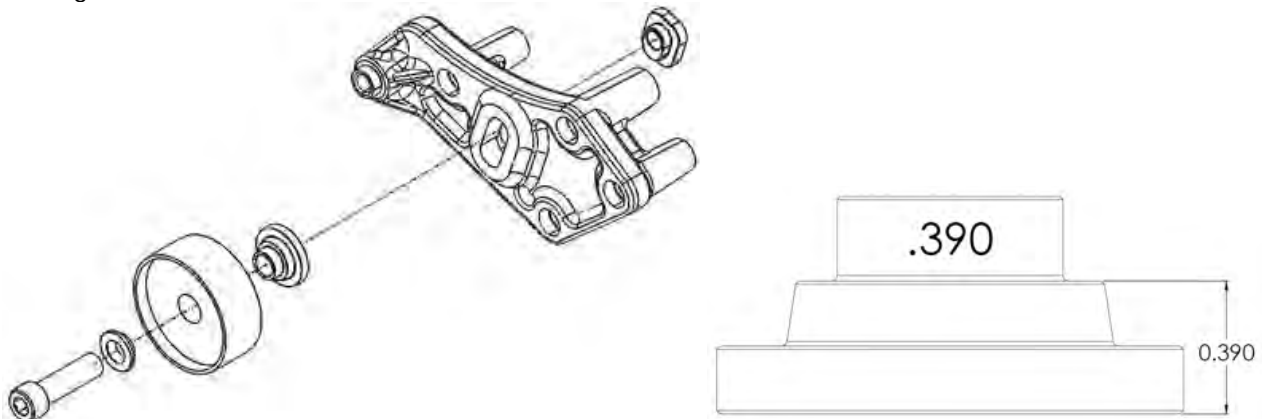

69. Install the supplied (1) grooved idler pulley #36326 to the idler plate using the (1) idler step washer and (1) ½"-13 x 2" SHCS. Torque idler pulley bolt to 30 lbs-ft. using a 3/8" allen socket. **NOTE:** Use light amount of anti-seize on threads.

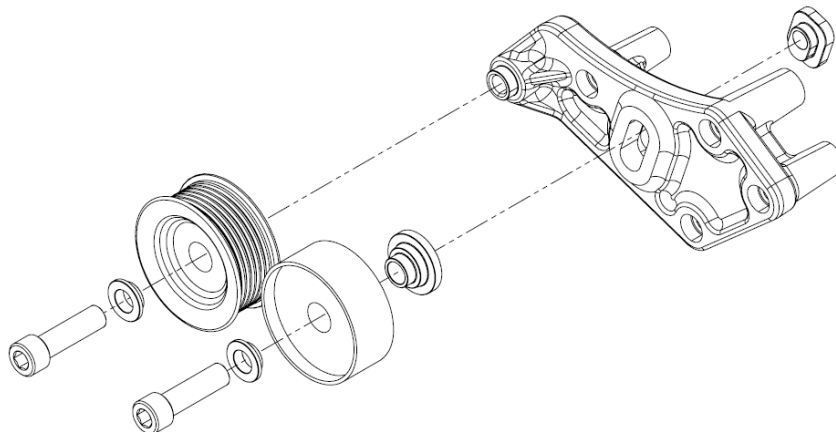

70. Install the supercharger pulley using the supplied (4) 6mm x 14mm SHCS using a 5mm allen socket. Leave hand tight until belt installation.
71. Install the supplied supercharger belt by following the routing diagram. Using an 15mm socket on a 1/2" breaker bar, open the factory tensioner to its max open position. Push the adjustable/sliding smooth idler pulley down as far as it can. Once in position, lock the adjustable idler pulley by torquing the SHCS to 18 lbs-ft. ***NOTE:** You must always put the tensioner at or near its max open position. Failure to set properly will result in belt issues during hard accel or decel. Changing supercharger pulley diameters may require different belt lengths.

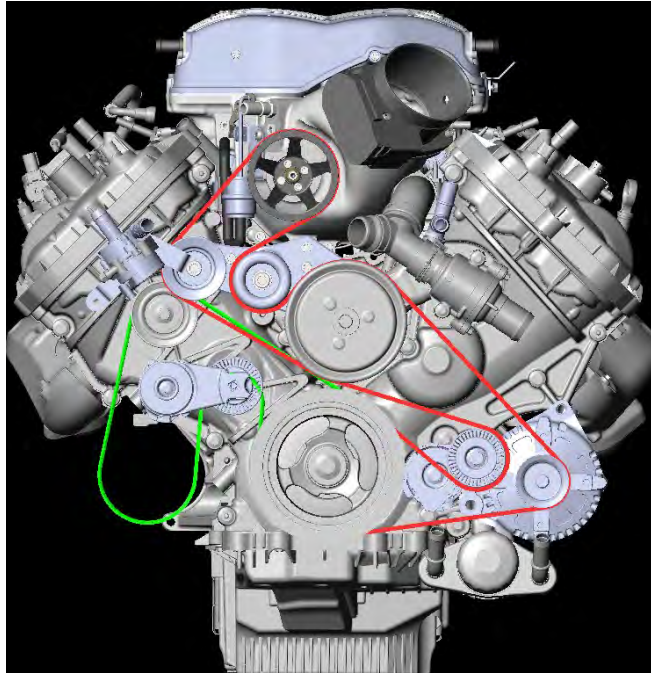

72. Torque the supercharger (4) 6mm x 14mm SHCS bolts to 130 lbs-in using a 5mm allen socket.
73. Install the supplied male to male fuel line coupler to the factory fuel feed hose. Connect 4" jumper hose to coupler and 180deg swivel fitting for fuel supply on the **LH**/driver side of engine. Press until they click and lock into place.
74. Modify the stock heater line, using the supplied hose and coupling. Cut the hose approximately 12" from the stock Tee fitting. Install the 45 deg heater fitting to water fitting previously installed. This will only fit between the throttle body and cylinder head. Route hose around front of engine, along radiator lines. Install supplied sheaving and heat shrink to hose, cut to fit. Couple hose using supplied couplers and shrink clamps. Apply medium heat to shrink clamps and heat shrink at ends of sheaving.

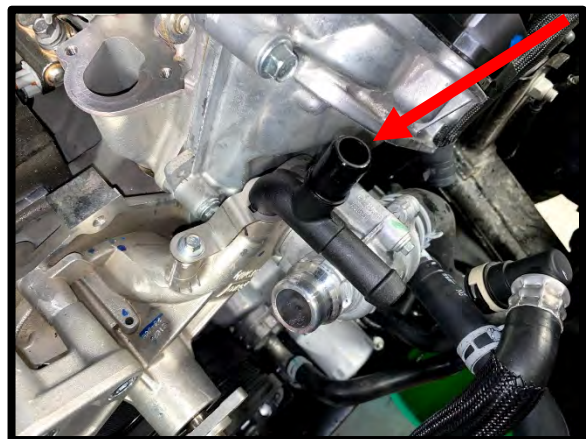
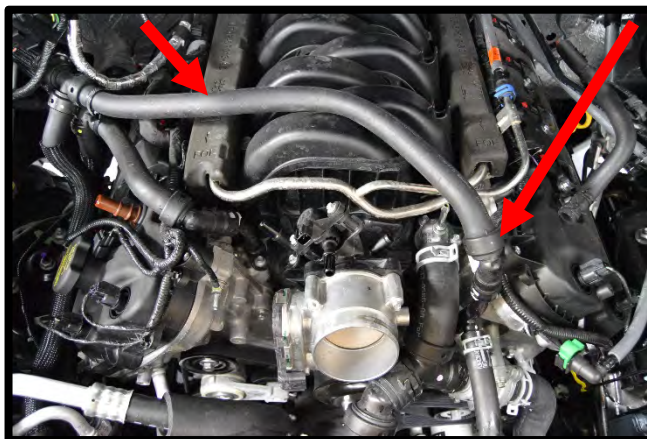

75. Install the supplied 3/8" ID with 55deg quick connect fitting hose to the EECPV barb fitting and **upper** quick connect fitting on SC inlet. Push until it clicks and locks into place.

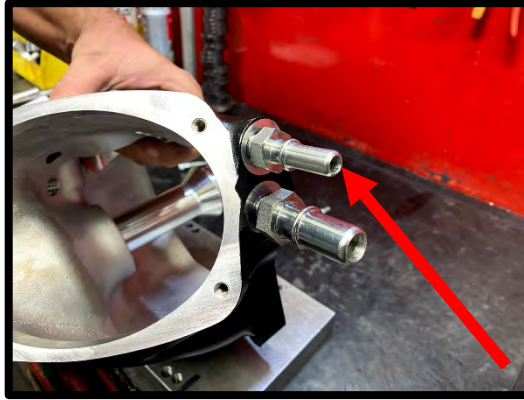

76. Install the supplied 1/2" ID x 14" with 90deg quick connect fitting brake aspirator hose (#HSF150-HS012) from the brake booster to the **lower** quick connect fitting on the supercharger inlet. Push until it clicks into place. **TIP:** For best routing, nestle in between cam cover and fuel rail, under the wiring and heater hose.

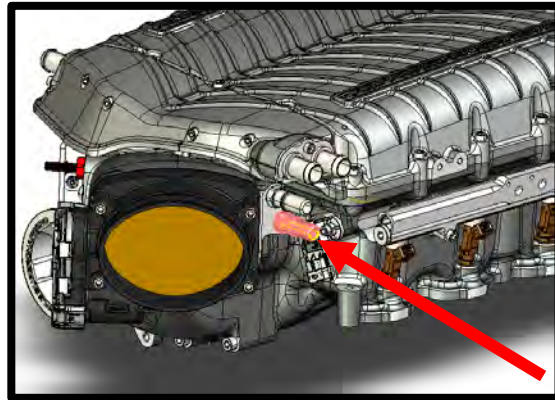
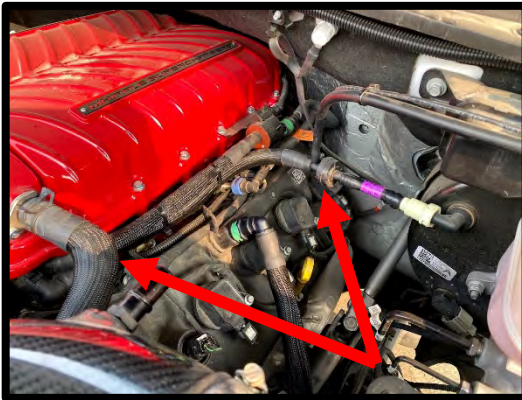

77. Install the supplied 5/8" ID x 9" PCV hose to the passenger side valve cover. Connect other end to the supercharger inlet 15.82mm quick connect fitting. Push until it clicks and locks into place.

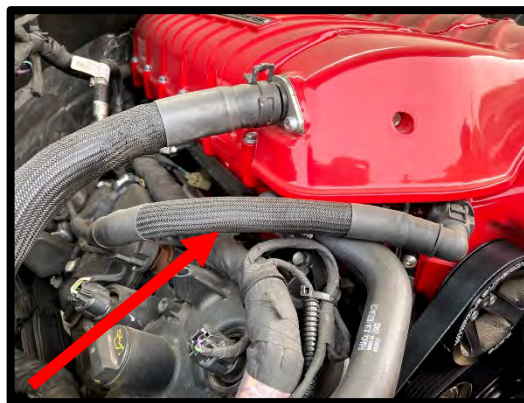

78. **(Stage 1 Stock throttle body)** Install throttle body adapter to supercharger inlet using the supplied (4) 6mm x 14mm FHCS (4mm allen socket) using the supplied gasket between TB adapter and SC inlet. Torque to 88 lbs-in.



79. **(Stage 1)** Install the stock throttle body using the (4) 6mm x 50mm FHSCS bolts using a 10mm socket.



80. **(Stage 2 Whipple 132mm Crusher throttle body)** Install throttle body to supercharger inlet, use the supplied gasket between TB adapter and SC inlet. Secure with the supplied (3) 6mm x 25mm SHCS and (1) 6mm x 50mm SHCS using a 5mm allen socket. Torque to 88 lbs-in.



81. Using a 10mm socket, remove the stock coolant reservoir **LH** side bolt. Install the IC filler tee bracket under the coolant reservoir mounting tab. Reinstall factory bolt. Secure filler tee to the bracket using the (2) 6mm x 14mm HHFCS (10mm allen socket).



82. Install the intercooler pump to the water reservoir using the supplied clamp and rubber strip (leave slightly loose to position after hose installation). Install the supplied 90deg rubber hose and pinch clamps to reservoir and intercooler pump. Once pump is in position, tighten clamp holding IC pump to reservoir. Note: Make sure pump outlet is facing directly up.



83. Remove the (4) bumper support bolts and clips using a 13mm socket. Install the supplied hex support stands to the bumper support. Use the 30mm hex stands on the bottom (2) bolts. Use the 45mm hex stands on the top (2) bolts. Torque to 15 lb-ft with a 13mm socket.



84. Install the supplied (4) rubber grommets to the LTR mounts. Install the supplied (4) aluminum LTR spuds to rubber grommets installed in LTR.



85. **(Dual fan installation)** Install the supplied (4) rubber strips to the bottom flat portion of the fan mount brackets. Clean the brackets with soap and water. Remove the protective tape from the rubber strip and install to the bracket. Install the (4) rubber feet per fan to the bottom of the fans.



86. **(Dual fan installation)** Install the (4) brackets to the fans by sliding the square tab into the fan notch and the steel channel bracket will slide on the outside. The angled side will face the fan. This slides together easier if the bracket is facing slightly up. Once these are lined up, push until the seat together. Repeat on the other (3) brackets. Leave nyloc nuts loose for now.



87. **(Stage 2 heat exchanger installation)** Carefully set both fan assemblies on top front of the LTR, space these evenly before installing.



88. **(Dual fan installation)** Carefully pull open brackets and push onto the LTR. Its best to do both ends at the same time otherwise the bracket can be at an angle and hard to get on. NOTE: Electrical connectors should face down.
89. **(Dual fan installation)** Carefully snug up the (8) nyloc nuts using a ¼" ratchet and 10mm socket. Do not over tighten.
90. Install the left and right brackets to the previously installed coupling nuts. Use the supplied 8mm x 16mm flanged hex bolts to secure. Torque to 15 lb-ft with a 13mm socket.

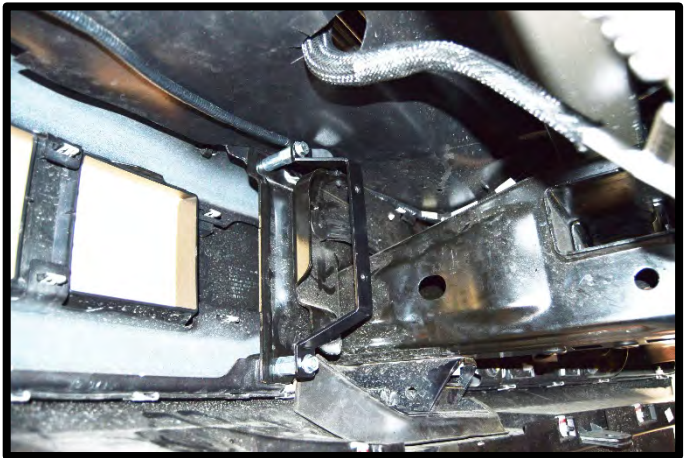

91. Install the LTR to the mounting brackets using the supplied (4) 8mm x 70mm counter sunk allen bolts, through the aluminum spuds, rubber grommet. On back side of heat exchanger flange, use the 1.70" aluminum spacer. Secure the (4) bolts using 5mm allen socket. **NOTE:** Low fitting is the feed on **LH**, top fitting is exit on **RH** side.

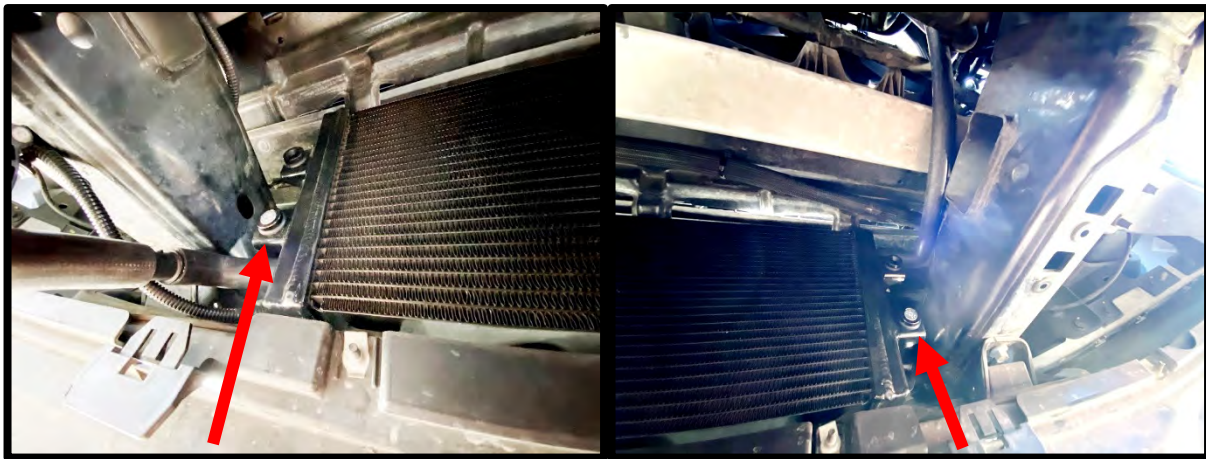
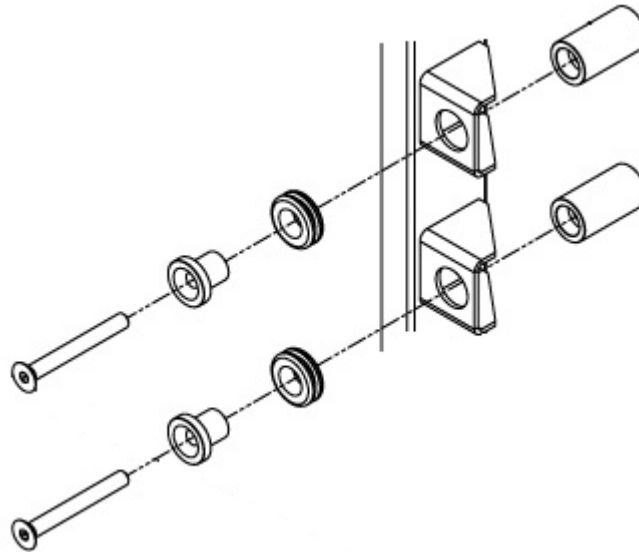

92. Install the 3/4" ID rubber hose (#18F150-HS006) from the **Bank 2 (OUTLET)** IC fitting to the IC filler neck. Secure both ends with supplied pinch clamps. **NOTE: NEVER SWITCH THE INTERCOOLER ROUTING, BANK 2 IS ALWAYS THE OUTLET!**

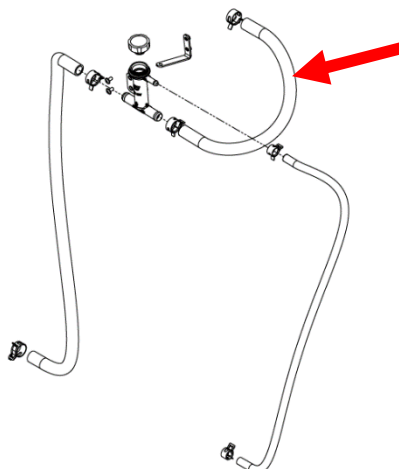

93. Install the 3/4" ID (#18F150-HS007) and the 3/8" ID (#18F150-HS008) rubber hoses to the IC filler neck. Secure with supplied pinch clamps. Connect the 3/4" hose to the reservoir 3/4" barb. Connect the 3/8" hose to the 3/8" reservoir barb. Secure both hoses with supplied pinch clamps. **NOTE: Ensure that this hose cannot kink or rub anything overtime.**

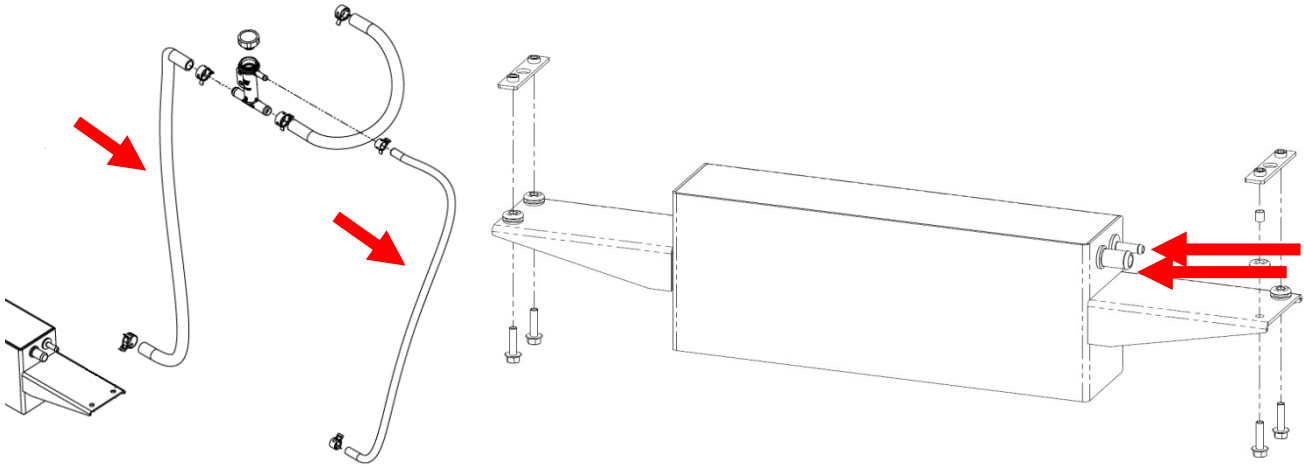

94. Install supplied 3/4" hose with 90deg end to heat exchanger top fitting. Route other end to **BANK 1 (INLET)** intercooler fitting. Secure with supplied constant tension clamps. ***NOTE:** Make sure the hose does not and cannot kink during routing. **DO NOT** lay the hose on the cam sensor wires, this will lead to failure over time.



95. Install the supplied (4) rubber grommets and steel bushing into the (4) holes located on the driver and passenger side frame.

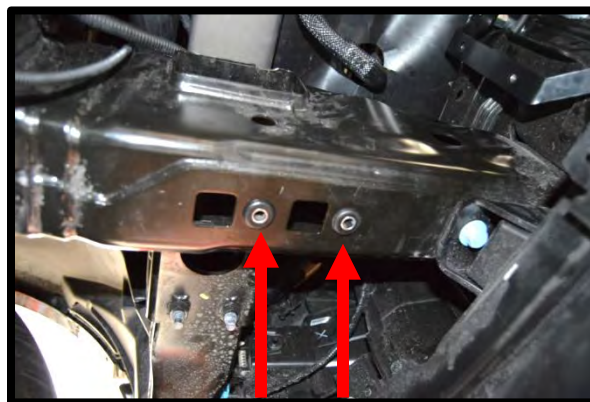

96. Install the supplied steel nut plates (2), (1) per side up through square opening with nuts facing up.



97. Install the IC reservoir to the (2) nut plates using the (4) 8mm x 25mm flanged hex headed bolt. Start (1) on each side to align holes to bushing. If off, you can use screwdriver to align the nut plate and bushing before installing the final (2) bolts. Torque to 15 lb-ft using a 13mm socket.

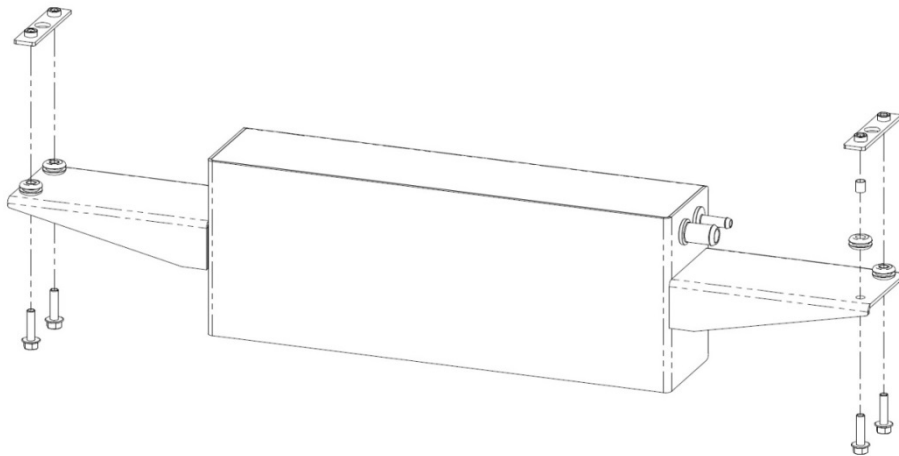

98. Install the 3/4" ID formed hose (F150-1700) from the LTR driver side top fitting that you previously installed, route to the IC pump outlet barb. Secure with supplied pinch clamp.
99. Install the 3/4" hose coming from the IC filler neck (F150-1400) to the 3/4" barb fitting on the IC reservoir. Secure with supplied pinch clamp.

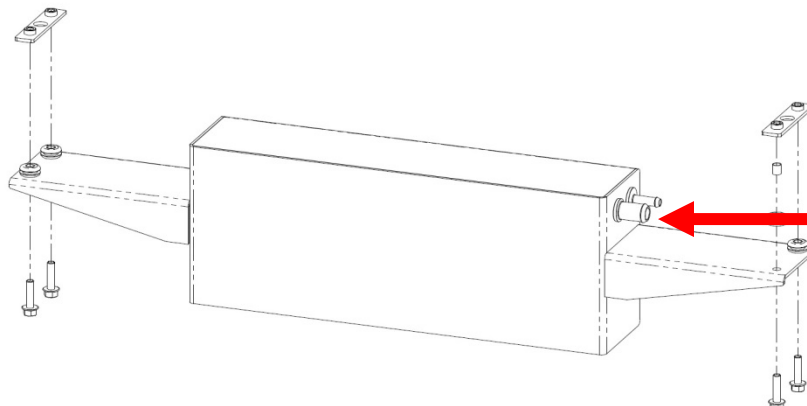

100. Install the 3/8" IC filler neck vent line to the 3/8" barb on the IC reservoir. Secure with supplied pinch clamp. Secure lines with zip-ties.

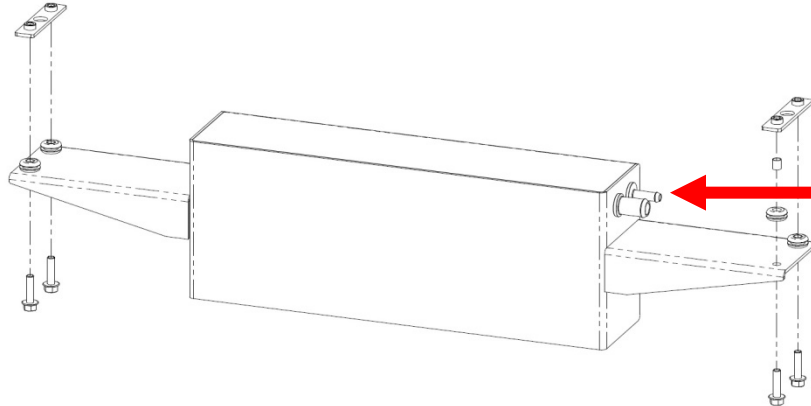

101. Install the supplied 3/4" ID hose with 90deg end from pump outlet barb to heat exchanger inlet fitting. Secure both ends with supplied pinch clamps.

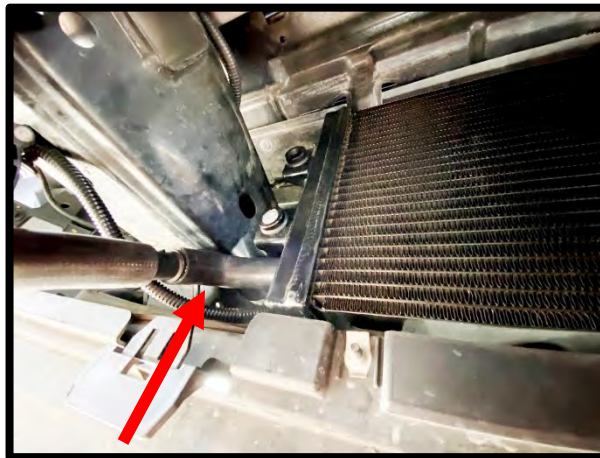

102. Lightly bend the (2) ground wire so it goes below the frame. **NOTE:** Failure to do so will rub airbox and push airbox towards firewall and cause fitment issues.



103. **(Complete kits)** Using a 3/8" drill bit, drill a hole for the baro/MAP sensor in the lower Whipple airbox. **NOTE:** This is to read barometric pressure, therefore its placement is not critical.



104. Install the supplied lower airbox into factory (2) hole locations. Using the supplied (2) 1.1" L x .30" W plastic push pins, secure front of snorkel to factory location.

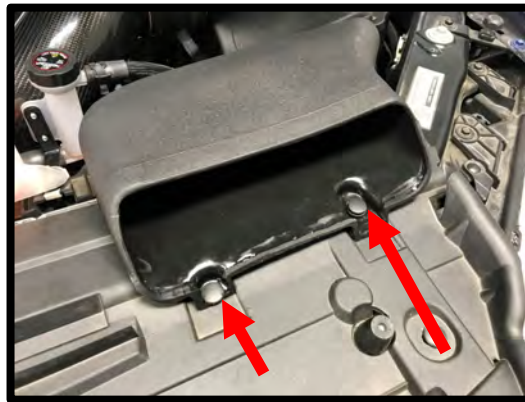

105. Install the supplied panel filter to the airbox lower. Install the upper airbox to the top of the filter. Secure the top to bottom using the supplied (6) 6mm x 16mm BHCS. Torque to 50 in-lbs. ***Caution:** Over torquing can result in pulling an insert out of plastic box.



106. Install the (1) supplied 13/16" to 1/2" rubber grommet into the supercharger inlet tube. Install the supplied 1/2" to 15.82mm quick connect fitting.



107. **(Whipple 132mm Crusher throttle body)** Install the supplied 5" ID x 2 1/2" silicone hose over air inlet tube and airbox lid. Install the 4 3/4" x 3" silicone hose over throttle body. Install the air inlet tube between the filter and throttle body. Slide silicone hose over throttle body. Secure all ends with the supplied (4) #80 hose clamps.



108. **(Stock throttle body installations)** Install the supplied 5" ID x 2 1/2" silicone hose over air inlet tube and airbox lid. Install the supplied reducer silicone hose over air inlet tube and stock throttle body. Connect the other end to the stock throttle body. Secure all ends with the supplied hose clamps (2) #80, (1) #64 and (1) #56 on throttle body.

109. Install the stock make up air hose to air tube fitting previously installed. Fittings may require some rotation to properly fit.

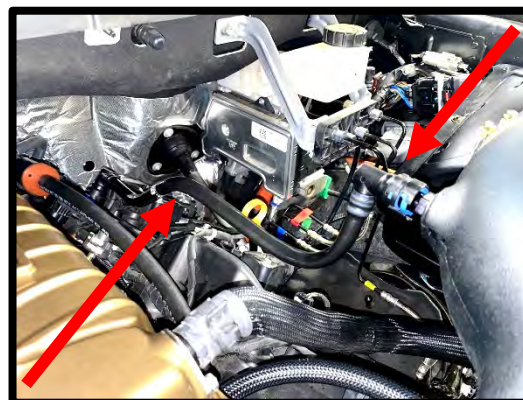

110. Connect the supplied 3-way to 4-way pigtail (driver side 3-pin IMRC connector) to the airbox MAP/Baro sensor previously installed. Secure pigtail with zip-ties.

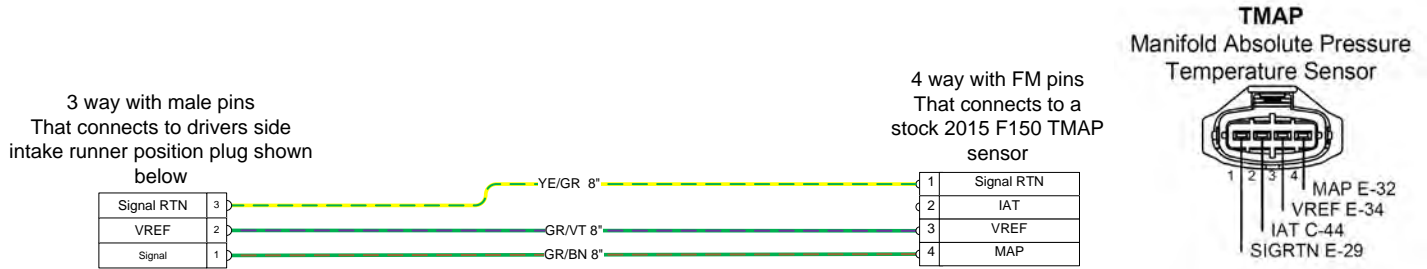

111. Secure driver side vent line quick connect fitting to the 5/8" fitting in the inlet tube previously installed.
112. Using a 10mm socket, remove the nut on the power stud, located on the positive battery connector. Install the IC pump relay power eyelet (red wire) to the power stud on the battery positive (+) stud. Use a 10mm socket to secure stock and IC power wire.



113. Remove the ground bolt from the passenger side inner fender using an 8mm socket. Install IC pump relay ground eyelet here. Secure with factory bolt using an 8mm socket.

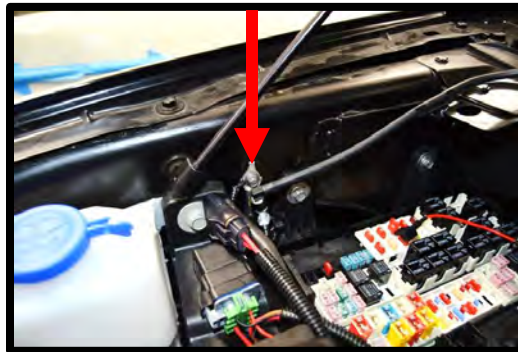

114. Pull the red 10amp fuse from position #105. Install the 10amp red fuse in the unused fuse slot on the fuse tap. Install the supplied fuse tap into position #105. Note: 10amp red fuse should be in bottom slot, 5amp should be in top slot. Make sure wire has enough room when fuse cover closes, route around fuses for clean installation.



115. **(Dual fan installation)** Connect the 12V eyelet to the 3rd power stud (same as IC pump previously installed). Splice the orange turn-on wire to the IC pump (#44). Use the supplied steel bracket to use previously installed push pin to secure relay and fuse. Route the wires down on the passenger side of radiator. Connect dual fan 2-way's to fan relay harness 2-way's. Zip tie wires for clean installation.

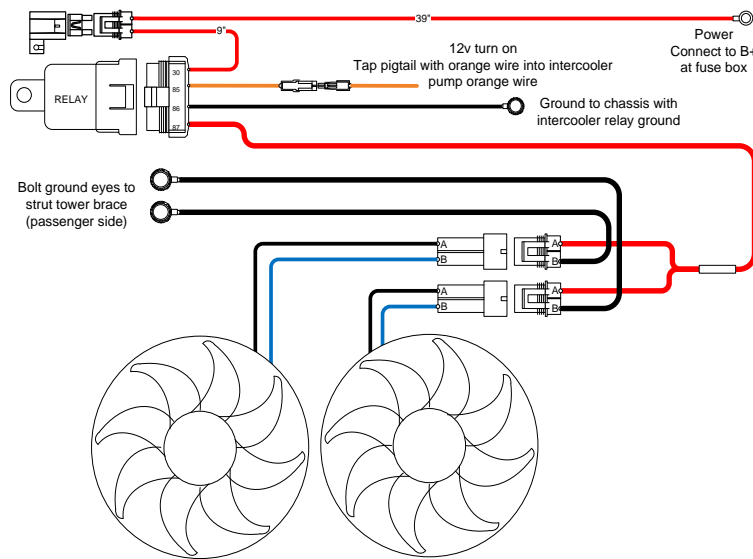

116. Secure the relay/fuse along with the harness for a clean installation.
117. Refill the Engine coolant. Verify that your coolant drain is closed, and use a filter/strainer to pour the recycled coolant/water mixture that you drained from the radiator. If necessary top off with a **Ford approved engine coolant**. Whipple also recommends running 2 bottles of Redline Water Wetter which can be found at most automotive parts stores. **⚠ WARNING!! DO NOT USE TAP WATER OR ANY NON-FORD APPROVED ENGINE COOLANT, THIS WILL CAUSE CORRISION IN THE SYSTEM. ** (Vehicles that come equipped with Ford Motorcraft Orange must use Motorcraft Specialty Orange.** Start engine to completely fill system.
118. Attach the negative cable to the battery and tighten using a 8mm wrench.
119. **(Complete kits)** Install the supplied 50-state legal sticker (when applicable) to the hood as the factory emissions sticker. Use light amount of acetone to clean surface before installing.

120. Attach the "91 OCTANE OR HIGHER" decal to the gas tank fill cap or door.



The electric water pump used on the Whipple SC system has a built-in micro-processor that will vary pump cycle speed when air bubbles are present in the system. If a significant amount of air is trapped in the system, the pump may cycle at a lower speed and pulsations are likely to occur resulting in poor cooling performance.

121. Using a Lisle 24680 Spill-Free Funnel, or equivalent, secure the appropriate filler neck adapter to the filler neck.
122. Attach the funnel and fill with a 50/50 mixture of coolant and distilled water until the funnel is half full. Whipple recommends Ford Motorcraft or Zerex G-05 to match the stock color. Whipple also recommends 1 bottle of Red Line Water Wetter or equivalent. Note: The Whipple IC system is compatible with all common types of antifreeze. **Never use tap water, this will cause corrosion and destroy the system.** The system takes approximately 2 gallons of fluid.
123. Turn the ignition to the **ON** position, after a brief delay, the electric pump motor will cycle. Air bubbles will begin to rise to the filler tee as the coolant level drops, continue to fill while pump is running. Once its done filling, turn the ignition key **OFF**, the level will drop, top off with fluid. Reinstall filler cap and turn the ignition **ON** and let run for 15 seconds. Turn key **OFF**, remove cap to release air. Repeat until the filler tee holds between minimum and maximum fill level with key **OFF**. To build more pressure in the intercooler system, try squeezing the intercooler hoses while the pump is cycling. Building pressure in the system will help push the trapped air from the intercooler system to the filler tee. It also helps to lift the filler neck 4"-8" higher than its mount to help purge the air. **NOTE:** Do not let the coolant level in the funnel run empty as this may introduce more air into the system.

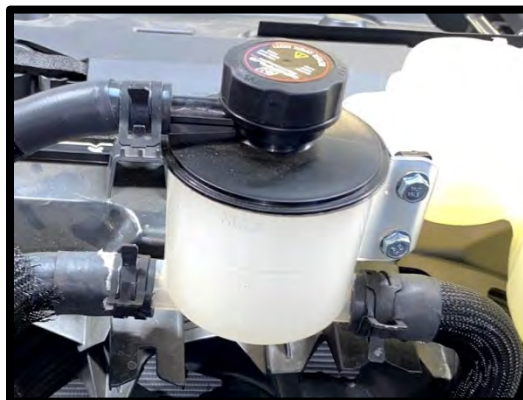

124. Cycle the ignition to the ON position again and repeat until the sound of the electric pump is continuous without any pulsation and the fluid level is met at the filler cap. **NOTE: During water pump start-up, it is normal for a slight pulsation to occur. Once the pump has reached its maximum cycle speed, no pulsations should be present. If any pulsations occur, there is air in the system. NEVER GO WOT UNTIL AIR IS BLED OUT!**

125. Several drive cycles may be required to completely purge the air from the intercooler system. During a drive cycle, the intercooler system will build up pressure as the supercharger temperature increases. Any residual air trapped in the system will have to be bled out when the cap is removed. Use a rag when removing in case there is excess pressure. **TIP: Never go WOT until air has been bled from IC system, engine failure could occur if not bled properly.**

WARNING: Always avoid removing the filler neck cap when the system is hot. The hot coolant is under pressure and may spray out causing burns.

WARNING: Triple check that the intercooler system is properly bled. Failure to do so can result in engine damage. Turn ignition on, let the pump run for 60 seconds, there should be zero cavitation during this test.

126. If your system included a flash tool, follow the included instructions to reflash the PCM.
127. Reinstall the grill shell in the reverse order. **Verify proper clearance to the intercooler hoses added, specifically the 180 deg heat exchanger feed hose as it will be close to the front grille. If interference is found, loosen pinch clamp and rotate hose away from grill shell.**
128. Turn the Ignition key on, do not start the engine (this will turn ON the fuel pump for 2 seconds). Inspect for leaks such as fuel, coolant, and intercooler coolant, correct as required.
129. Start the engine and let idle. The engine should idle normally between 600-800 rpm at normal operating temps. Inspect for leaks. After running for 2 minutes turn off engine and inspect the level in the engine radiator and the Intercooler tank. With the key in the ON position engine off, inspect the coolant in the intercooler tank, the coolant should flow in the tank. If it does not, the coolant circuit has an air pocket trapped in it. To remove the air pocket, with key off, remove the IC filler neck cap and fill with coolant to mid-level. Reinstall cap, turn key on, for 15 seconds. Turn key off, remove fill cap and repeat until all air is bled.
130. Before driving, make sure that you have 91 or higher-octane fuel in the system. Not ½ tank of 87 and ½ tank of 91, all 91 or better fuel in the system. Whipple does not recommend octane booster for low octane fuel. The system adapts to higher octane fuel when it's available.
131. Test drive vehicle for the first few miles under normal driving conditions. Listen for any noises, vibrations, engine misfire or anything that does not seem normal. The supercharger does have a slight whining noise under boost conditions, which is normal. If you chose the 132mm billet throttle body, idle may take a few minutes to learn. Using the Tomahawk tool and the data logging options, use the Whipple List and check the MCT reading while operating. This is the Manifold Charge Temperature. This is post intercooler, normal temps are 0-40deg F over ambient under normal conditions.
132. Re-check the radiator and intercooler reservoir coolant level regularly over the first 1,000 miles, top off level as needed. Do not operate at WOT until IC system is bled properly.
133. Re-check SC oil level regularly over the first 1,000 miles, level may drop very slightly as it fills the bearings and cavities.
134. Inspect belt system, readjust if necessary. It's common for the belt to stretch after first use.
135. After the initial test drive, go through the belt tensioner process again. When next you start driving, gradually work the vehicle to wide open throttle runs. Listen for any engine detonation (pinging). If engine detonation is present, let up on the throttle immediately. Most detonation causes are low octane gasoline still in the tank. The F150 uses factory wide band O2 sensors, which means it will control air fuel ratio to the target. Fuel trims will adapt for variances. Fuel pressure is 58psi +/- 5psi and never should dip below the specified margin. Trucks with high mileage may have clogged fuel filters or deteriorated fuel pumps. Any truck with 50,000 or more miles should verify fuel pressure during testing.

136. If you have questions about your vehicles performance, please check with your installation facility or call Whipple Superchargers at 559.442.1261, Monday through Friday from 8am to 5:00pm, pacific time or email questions to tech@whipplesuperchargers.com.

⚠ WARNING!! Verify the bypass actuator is working properly. To monitor, look at the bypass arm when the motor is not running. Start engine and verify that the actuator arm has opened. This arm will be extended when the engine is above 1" of vacuum (boost) and will be open when there is more than 1" of engine vacuum.

There is a great deal of misinformation about the function of supercharger bypass systems. The supercharger is a positive-displacement pump; that is, so long as it is rotating, it is always pumping air. During low demand or high vacuum operation (i.e. idle, deceleration, and light throttle cruise), the pumping action is undesirable as it creates unwanted heat and noise. The bypass circuit, when open, prevents any pressure buildup across the supercharger and allows air to circulate through the rotors, allowing the supercharger to "idle" freely during these conditions. This results in reduced noise, and by reducing heat buildup in the intake, significantly improves street and strip performance. As throttle demand increases, the bypass circuit is closed, resulting in full performance and strip performance. As throttle demand increases, the bypass circuit is closed, resulting in full performance from the supercharger. The bypass circuit is never used to limit or control boost during full-throttle operation and defeating or altering the bypass function will not result in improved performance in any condition, and will result in poor drivability and possible supercharger damage.

MAINTENANCE AND SERVICE

Be sure to follow the maintenance and service recommendations below to optimize the life and performance of your Whipple-supercharged vehicle.

For best performance and continued reliability it is essential to adhere to the following guidelines:

1. Use only premium grade fuel (91-octane or higher). RON+MON/2. The PCM calibration will automatically detect higher octane levels and will increase power accordingly.
2. Always listen for any sign of spark knock or pinging. If present, discontinue use immediately and consult your vehicle owner's manual.
3. Do not operate the vehicle at large throttle opening if the MIL lamp is on steadily. This indicates an electronic engine control malfunction: reduce throttle opening to a safe location. Use the supplied flash tool to read the DTC and consult with Whipple or your Whipple dealer.
4. Check the supercharger oil level at every engine oil change. Add Whipple SC oil to the supercharger if required. Do not overfill the supercharger rear gear case.
5. Change the oil in the supercharger every 100,000 miles. Use Whipple SC oil or Ford #XL-4 only.

!! CAUTION !!

Severe damage to the compressor will occur if you overfill the supercharger rear gear case.

6. Do not operate the vehicle at large throttle opening if the MIL lamp is on steadily. This indicates an electronic engine control malfunction: reduce throttle opening and consult your vehicle dealer.
7. Inspect and clean your high-flow air filter element every 7,500 miles.
8. Inspect and replace spark plugs every 20,000 miles. Only run specified NGK plugs.
9. Follow your factory service intervals for oil changes and other typical maintenance items.
10. Check the supercharger/accessory drive belt. Adjust or replace as required

!! CAUTION !!

Any modification to your vehicle's new computer program may cause serious damage to the engine and/or drive train. The PCM is locked to the VIN, never let anyone, including dealerships install updates to the PCM. Modifications to the PCM will lock power to stock power levels.

CONGRATULATIONS

Your new Whipple Supercharger is engineered to significantly increase your engines power across a broad range of RPM's. It is Whipple's goal to improve your driving experience for many miles and years to come.

Whipple Superchargers operate as an air pump and contain internal rotors that are driven by the engine's crankshaft and serpentine belts. The supercharger compresses outside air and channels it into the engine's intake ports. Because of their design, superchargers may generate some additional noise over the standard, normally aspirated induction system.

At idle, you may hear a medium-pitch rattle from the supercharger main housing. This will diminish at about 400-500 rpm above idle.

You may also experience a muffled high-pitched whine during acceleration. This is caused by the pumping action of the supercharger compressing air and only occurs during boost conditions. It is inaudible during part-throttle acceleration. These are normal noises associated with any supercharger and have no effect on supercharger performance or engine durability.

Your supercharger is warranted by Whipple Superchargers, please see your terms and conditions on the back of your invoice for more information in regards to the limited warranty. NOTE: Whipple Superchargers will not authorize any warranty repair work or supercharger replacement for normal noise.

IMPORTANT INFORMATION

BOOST LEVELS

All Whipple kits are shipped with boost levels that Whipple feels achieves maximum power while maintaining reliability with stock engines (@ sea level). Additional pulley's are available for lower and higher boost levels, the supplied calibration (complete kits) for the original pulley or larger (lower boost). Higher boost levels must run higher octane levels such as 104, 110, 116, etc. or be custom tuned. One can always lower boost with no cal changes required.

EXHAUST

Cat-back exhaust systems help reduce heat and minimize exhaust back pressure. They do not affect the calibration and are always a good idea for added safety and performance. Long tube headers and/or high flow cats require custom calibrations and are not supported by Whipple.

AIR FUEL RATIO

Air fuel ratio is the measurement of the amount of air and fuel being burned during the combustion process. In order for you to monitor the air fuel ratio, use the stock wide band O2 sensors via data logging the OBD port with the Whipple flash tool.

The Whipple supplied calibration has is tuned for WOT 12.00:1 considering 91 octane fuel with 10% Ethanol. Whipple maintains Catalytic saver mode which richens the target air fuel to maintain cat life. During this, the air fuel may lower up to one full point to maintain temps.

FUEL OCTANE

Never run a fuel octane that is below 91octane, $(RON+MON)/2$ and never run fuel with more volume than 10% Ethanol. It is recommended, when available, to run 92-94 octane. Never mix mid-level (below 91) with 91+, this is very dangerous and can cause severe engine damage. Do not attempt to increase octane ratings with generic octane boosters, these are very hard on spark plugs and many brands do very little to the actual octane rating (1 point is .1 octane). For emergency situations and racing applications, the best octane booster found to date is Boostane (#1 choice). Some other brands are hard on spark plugs so constant use will require increased spark plug maintenance. The PCM constantly adapts, if it senses better fuel, it will increase power accordingly.

ENGINE COOLANT

Whipple recommends running a 50/50 mix of distilled water and coolant. The engine temp should run between 200-210F under normal driving conditions. We also recommend 1-2 bottles of Red Line Water Wetter coolant additive. This will reduce air bubble insulation, which increases overall engine temp.

FUEL LEVEL

Never operate at WOT when the vehicle fuel levels are below a 1/8 tank. Low fuel levels could cause the fuel pump to cavitate and you'll have fuel flow spikes resulting in lean conditions and consequently detonation.