

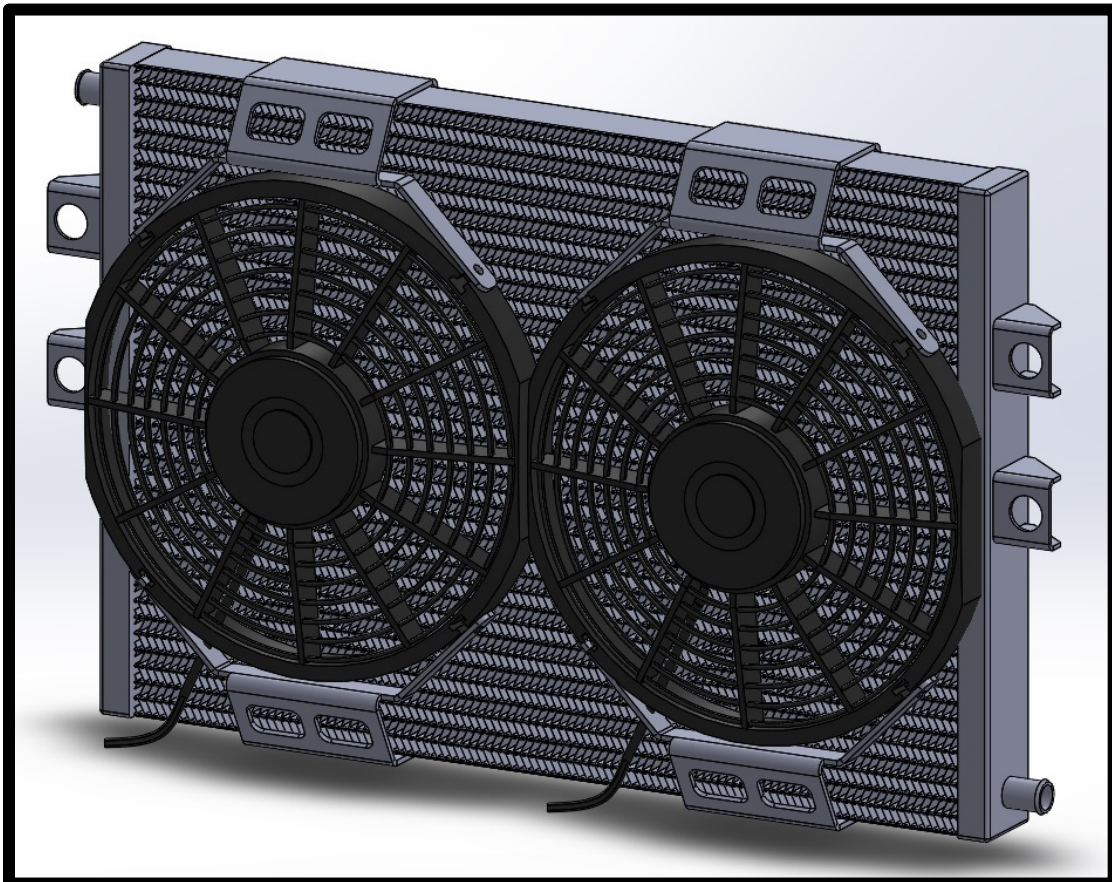

## *DUAL FAN INSTALLATION MANUAL*

*2011 AND UP FORD MUSTANG GT 5.0L COYOTE*



**WHIPPLE SUPERCHARGERS**

3292 NORTH WEBER AVE

FRESNO, CA 93722

TEL 559.442.1261

FAX 559.442.4153

[WWW.WHIPPLESUPERCHARGERS.COM](http://WWW.WHIPPLESUPERCHARGERS.COM)

*A COLOR PDF OF THIS MANUAL IS AVAILABLE, EMAIL  
[TECH@WHIPPLESUPERCHARGERS.COM](mailto:TECH@WHIPPLESUPERCHARGERS.COM) FOR A COPY*

## **WARNING**

**\*\*NOTICE:** Installation of Whipple Supercharger products signifies that you have read this document and have agreed to the terms stated within.

It's the purchaser's responsibility to follow all installation instruction guidelines and safety procedures supplied with the product as it's received by the purchaser to determine the compatibility of the product with the vehicle or the device the purchaser intends to install the product on.

Whipple Superchargers assumes no responsibility for damages occurring from accident, misuse, abuse, improper installation, improper operation, lack of reasonable care or all previously stated reasons resulting from incompatibility with other manufacturer's products.

There are no warranties expressed or implied for engine failure or damage to the vehicle in any way, loss of use or inconvenience or labor reimbursement. This includes merchantability and fitness.

The information contained in this publication was accurate and in effect at the time the publication was approved for printing and is subject to change without notice or liability. Whipple Superchargers reserves the right to revise the information presented herein or to discontinue the production of parts described at any time.

## **DUAL FAN INSTALLATION**

It is strongly recommended that you read through this guide **before** you begin installing the 10-Rib upgrade.

1. Locate the stock ground wire bolt, located on RH side of vehicle, next to strut tower brace using an 8mm socket and remove. Install the dual fan secondary ground eyelet to the same location as the intercooler relay harness ground eyelet (black wire) along with factory ground wire. Reinstall bolt using an 8mm socket.

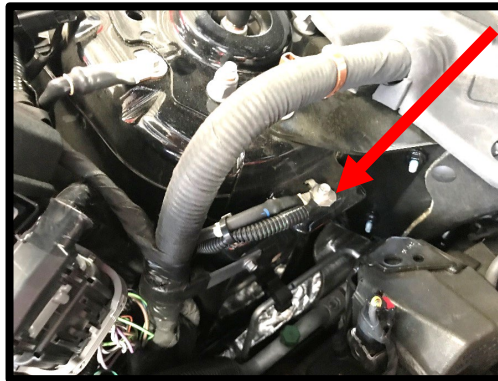

2. Open the fuse box lid. Using a 10mm socket, remove the 12V (+) power stud nut from the far post. Install the dual fan relay power eyelet (red wire) to the 12V stud. Use a 10mm socket to secure stock and IC power wire.

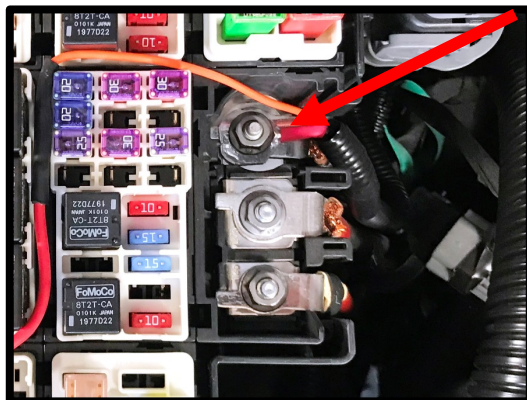
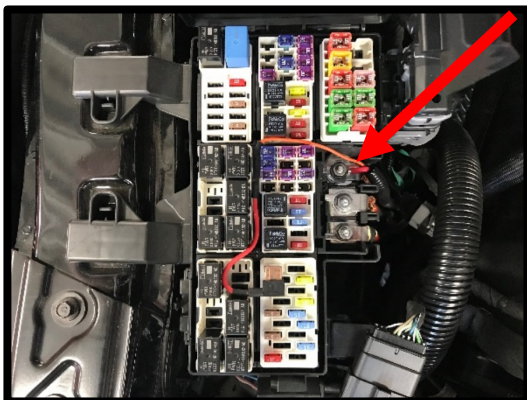

3. Mount the dual fan relay and fuse holder to the factory wire harness, secure with zip-tie. Route the fan 2-way wires to the fans. Secure harness using zip-ties.
4. (2015+) Connect the fan turn on, one-way connector from the IC pump relay to the dual fan relay one-way.

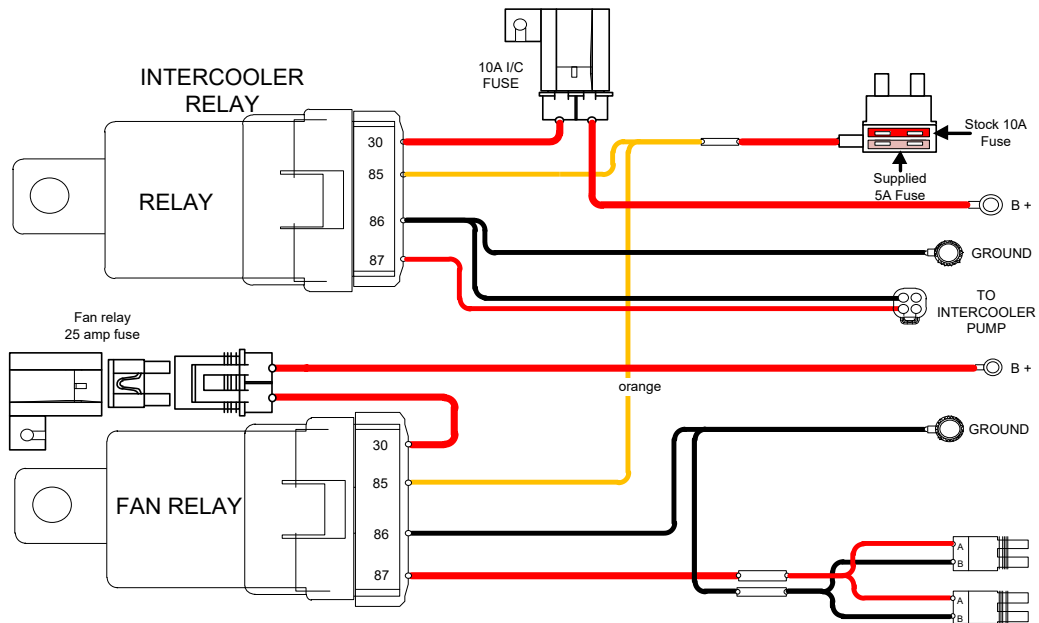

5. (2011-2014) Connect the fan turn on, one-way connector from the IC pump relay to the dual fan relay one-way.

